

U

113

.2

TM10:405

1942

UC-NRLF



B 3 245 387



4 Ed - new
TM 10-405
April 24, 1942
Changes #1-3.

TM 10-405

415. WAR DEPARTMENT

TECHNICAL MANUAL

✱
THE ARMY COOK

April 24, 1942

NOTE.—No initial distribution of this manual will be made. TM 2100-152 (December 31, 1935) and TM 10-405 (June 9, 1941) will be used until no longer serviceable.



Public Domain, Google-digitized / http://www.natmlu.usc.org/access_use#_pb-google

U113
.2
TM 10-405
1942
TM 10-405
C 1

TECHNICAL MANUAL ★ ★

THE ARMY COOK

CHANGES }
No. 1 }

WAR DEPARTMENT,
WASHINGTON, December 11, 1942.

TM 10-405, April 24, 1942, is changed as follows:

79. Installation of Army field range No. 1 in baggage car.—
a. To install the field range No. 1 in a baggage car as part of an emergency kitchen equipment when kitchen cars are not available, construct a box 7 feet 8 inches long by 3 feet 4 inches wide and about 12 inches deep (inside measurements), with bottom, using 1½- or 2-inch material as available. Line the sides * * * 2 inches of the top. Place a brick at each of the four corners where the range will sit. Place range in box * * * installed in the above manner.

* * * * *
[A. G. 062.11 (9-24-42).] (C 1, Dec. 11, 1942.)

BY ORDER OF THE SECRETARY OF WAR:

G. C. MARSHALL,
Chief of Staff.

OFFICIAL:

J. A. ULIO,
Major General,
The Adjutant General.

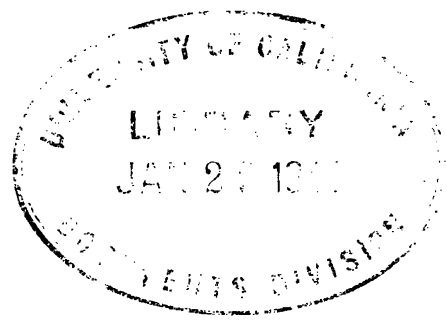

Public Domain, Google-digitized / http://www.naturtut.usc.org/access_use#_pb-google

TECHNICAL MANUAL

THE ARMY COOK

CHANGES }
No. 2 }

45 WAR DEPARTMENT,
WASHINGTON, D. C., 18 June 1943.

TM 10-405, April 24, 1942, is changed as follows:

74. Care of ranges and cooking utensils.

* * * * *

b. (Superseded.) *Army range No. 5.*—(1) *Description.*—The Army range No. 5 is installed in many kitchens which are located in permanent barracks. Its entire exterior is made of open-hearth range steel, hand hammered, and closely riveted. It is painted with a black japan, which is baked on in an oven. The cast iron castings are made of the best grey iron, smooth, soft, and well tumbled in a rattler, and are free from core and surface sand, rust, and grease. (See fig. 18.1.)

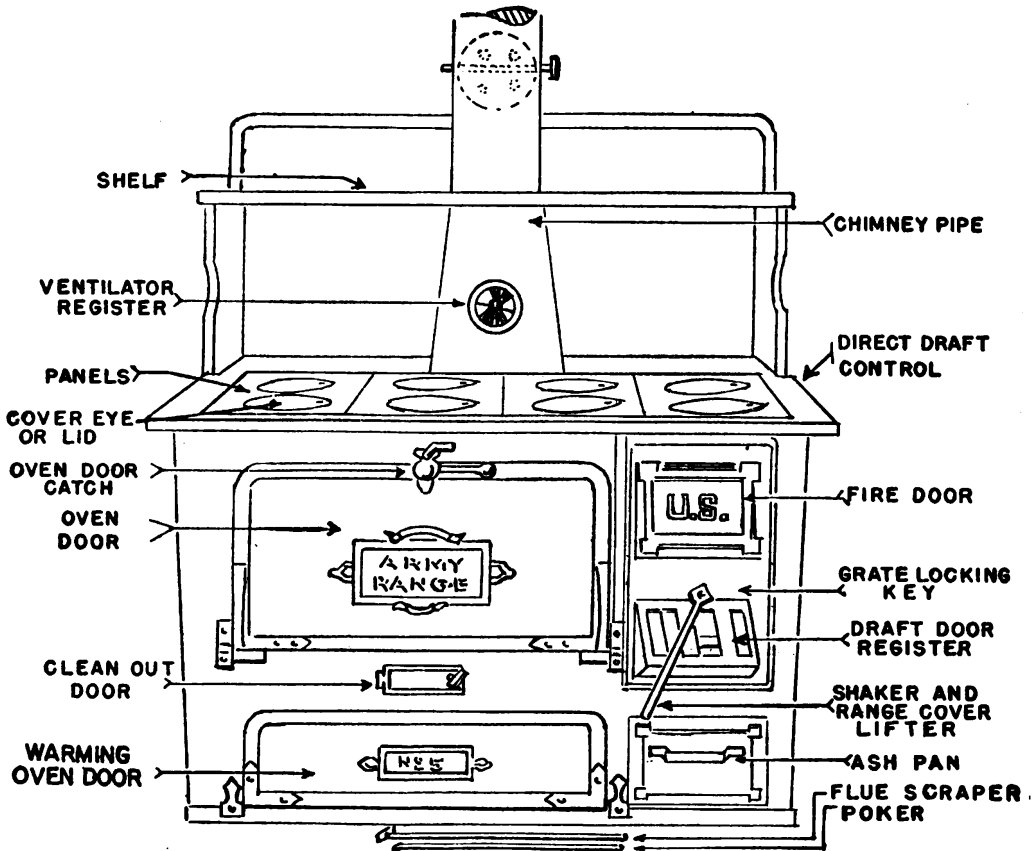

FIGURE 18.1—Army range No. 5.

[A. G. 300.7 (5-19-43).] (2, 18 June 1943.)
533463°—43

(2) *Firing Army range No. 5.—(a) Cleaning grate of ashes.*—To dump ashes from the firebox, withdraw the grate locking key and turn the grate over with the shaker. Return the grate to its normal position with the level side of the grate forming the bottom of the firebox. Insert the grate locking key.

(b) *Starting fire.*—To start the fire, lay crumpled paper on the grate and add enough dry kindling to hold the fire for several minutes. Then open the draft door register, the direct draft damper, and the flue stopper, and close the ventilator register. Ignite the paper and replace the range panels and covers. When the wood is ignited and holding fire, about one small shovelful of coal should be added. After this coal has ignited, more coal should be added to build up the fire. Finally, the direct draft damper should be closed. If this is left open after the fire has been started, the oven will not attain a satisfactory temperature.

(3) *Maintaining proper fire.—(a)* The fire should never be built up higher than 2 or 3 inches below the level of the oven top or the firebox lining. If the firebox is stuffed with coal, the following complications may develop:

1. Decrease in draft efficiency.
2. Loss of heat on water backs, in oven, and other parts of the range.
3. Greater accumulation of soot and ash dust around the oven and in the pipes and chimney.
4. Waste of coal and higher operating costs, because of incomplete burning of coal.
5. Heat intensified on the range panel and covers, making them red hot and subject to warping or cracking under heavy weights.
6. Cooking results below standard due to poor draft and heat circulation.

(b) The eyes or lids should never be used as a fire door. This practice results in a dirty range top due to soot and coal dust being dropped upon the heating surface, and causes unnecessarily soiled cooking utensils. If the range is fired through an eye, excessive coal may be dumped on the fire, and may pile up on the top of the oven chamber and burn through the top of the oven.

(c) Only small amounts of coal should be fed to the range at one time and coal should be added frequently. This will provide an even

heat and will result in a smaller consumption of coal. Allow the new coal to remain on top of red coals until it has ignited. Then stoke the fire, breaking up the fused new coal and mixing it with the red coals.

(d) After stoking, be sure that the fire is raked principally to the front of the firebox. Do not permit ashes to accumulate against the water back. This reduces the heat against the water back and results in insufficient hot water.

(e) An intensely hot fire should never be maintained. Such a fire is not necessary for good cooking; on the contrary, it often causes poor cooking, since foods cooked both on the top of the range and in the oven may become scorched or overcooked. An intensely hot fire also tends to damage hot water piping and warp the top sections of the range.

(4) *Care and cleaning Army range No. 5.*—(a) *Ashes.*—Empty the ashpan as in (2) (a) above as often as necessary to prevent the ashes from accumulating above the sides of the pan. When ashes are allowed to collect above this point, heat is intensified on the bottom of the grate, causing it to burn out more quickly. Also, when ashes are allowed to pile up against the draft door register, the draft is often retarded.

(b) *Care of top panels and range covers.*—There are four top panels on the Army range No. 5, each of which contains two range covers. The position of these panels and covers should be rotated every day or so to prevent them from warping.

(c) *Care of oven doors.*—Allowing heavy boilers to remain for any length of time on opened and unsupported oven doors will cause the doors to warp or bend. If this occurs, the oven door will not fit flush against the front sheet of the range, allowing oven heat to escape and making it difficult to keep the temperature uniform.

(d) *Polishing range.*—The range may be polished by rubbing it with a greased rag. This should be done, however, only after the range has been cleaned and is absolutely free of carbonized food residue, coal dust, etc., in its crevices and depressions as well as on its flat surfaces. If rags are used, they should be only slightly greased and after the range has been rubbed with a greased rag it should be wiped over again with a dry rag to remove any excess grease. Grease containing salt should not be used. If stove polish is used, it also should be applied sparingly, and after the polish has dried the range should be rubbed over again with a dry cloth or G. I. brush. A greasy cloth applied daily over the entire range keeps it in better condition than stove polish applied once a week.

(e) *Cleaning soot from range.*

1. *Top panels and range covers.*—Invert, and brush soot from bottom.
2. *Clean-out doors.*—First scrape ash dust and soot with flue scraper from the top side of the oven, and push it down the space at the left side of the oven. Clean both right and left sides of this space with a flue scraper. Scrape the ash dust and soot thus collected out of the clean-out door together with the soot collected on the bottom sides of the oven.

(f) *Stovepipe.*—Clean soot from the horizontal stovepipes with a broom or a mop, the head of which is covered with cloth or burlap. Care must be taken not to disconnect stovepipe connections. Soot can be partially cleaned from vertical stovepipes by tapping them lightly with a broad, flat stick, taking care not to dent or disconnect them. The outside of the chimney or stovepipe can be cleaned by frequent dusting with a dry cloth. Occasionally it should be washed with soapy water and polished with a dry cloth. To prevent rusting, the stovepipe should be polished as described in (d) above. In all cleaning, care should be taken neither to disconnect stovepipe connections nor to force pipes into elbows or connections in such a manner that the draft suction is impaired or cut off.

(g) *Mantel.*—The back of the mantel, the mantel shelf, and the left and right ends of the mantel have baked japan surfaces, and are properly cleaned with soapy water. To polish, a dry cloth should be used. Sharp abrasives or instruments that would scratch or crack the finish should be avoided.

(h) *Other parts.*—The parts which are listed below are properly and satisfactorily cleaned with G. I. or round-wire brushes: top, bottom, and sides of bake oven; top, bottom, and sides of warming oven; top, front, rear, and sides of range, excluding mantel; and oven rack. If spilled food or other residue has been burned in or carbonized on these surfaces, it will be necessary to use a harder abrasive instrument than the G. I. or round-wire brush. Flat steel brushes, emery cloths, or sharpened hard-steel instruments such as cold chisels, or sharpened steel spring leaves, will be found adequate for scraping surfaces. In general, no range can be considered thoroughly clean until all dirt, food, and other residue are cleaned from the crevices and spaces where various parts fit together; also from screw eyes, and from indentations and raised surfaces of name plates, reinforced edges, hinge connections, and all other mechanical and ornamental features of the range.

(5) *Regulating Army range No. 5.*—There are four appliances on the Army range No. 5 by which draft and temperature can be regulated.

(a) *Draft door register.*—The draft door register regulates the amount of air circulating up through the firebox into the range, thereby controlling the degree of draft necessary to force the burning of the fire. The register is a sliding door which can be closed, opened partially, or fully opened to diminish or increase the air circulation and the burning rate of the fire. If sufficient draft does not develop when the register is fully opened, the draft door itself can be opened outward to obtain the maximum degree of draft.

(b) *Direct draft damper.*—The direct draft damper controls the direction of draft circulation within the range. When the damper is closed, it causes heat to circulate entirely around the oven, entering the stovepipe through the flue opening just below the bottom of the oven. This action heats the oven on the top, bottom, sides, and rear. When the damper is open, the heat is drawn directly from the firebox to the flue opening in the chimney just above the top of the oven where the damper is located. Since heat is drawn up to the flue opening, it does not circulate around the oven and the oven is described as having only top heat. The direct draft damper should be kept closed at all times, except when the fire is being started. If for some reason only top heat is required in the oven, or if the oven is not to be used, the damper may be opened. To close, the direct draft damper control is turned counterclockwise; to open it, it is turned clockwise.

(c) *Ventilator register.*—The ventilator register reduces oven temperature. If during baking or roasting, heat increases above the desired temperature, it can be reduced by “cracking,” or partially opening, the ventilator register. Also, when the oven has greater top heat than bottom, these temperatures can be made more equal by “cracking” the register. Except for these purposes the ventilator register should always be closed.

(d) *Flue damper.*—The flue damper is used when the fire is banked to diminish the draft suction through the chimney and to decrease the burning rate of the fire.

(6) *Inspection, Army range No. 5.*—The following is a check list which may be used for inspection of Army range No. 5:

(a) *Ashpit.*—See *b* (2) (a) and *b* (4) (a).

(b) *Fire glow in ashpit.*—A red glow appearing in the ashpit indicates that the grate is free from an excessive collection of ashes and clinkers. If there is no red glow, it is an almost certain indication that

accumulated ashes and clinkers in the bottom of the firebox are preventing an effective draft. The fire should be stoked.

(c) *Range top panels and covers.*—The condition of panels which do not fit properly on the range top, and covers which do not fit flush in the panels, is often caused by the warping of panels and covers due to overly long exposure to excessive heat. The panels should be changed without delay, and the manner of firing the range should be checked. See that the fire level is maintained no higher than 2 or 3 inches below the top of the oven. Also check under the range panels to see whether the backbone which supports the panels has not become disconnected from the panel frames and oven top.

(d) *Accumulation of soot and ash dust.*—Check the bottom of the range panels and covers, the top and bottom sides of the oven, and the clean-out compartment for accumulation. Soot and ash dust must be cleaned from all parts of the range daily for continued efficient and uniform performance.

(e) *Exterior range surfaces.*—The exterior range surfaces must be clean and free from spilled coal, ashes, dirt, and food residue. This includes screw eyes, cracks, and indented surfaces.

(f) *Interior oven and warming surfaces.*—Same as (e) above.

(g) *Grate locking key.*—Check grate locking key to see that it is in place. If the key is missing, the grate may shift or turn when the fire is stoked, causing the fire coals to fall to the ashpan.

(7) *“Trouble” check list.*—(a) *Fire not burning properly.*—If the fire is not burning properly, check the grate to see that it is not inverted. If the grate is inverted, ashes will not fall into the ashpan and air can enter over the top of the fire instead of up through the grate, preventing the free burning of the fire. Warped range covers which permit air to enter above the fire also retard its free burning. Stovepipe and chimney connections which have become telescoped into the elbow or angle connections, thereby reducing the draft space, will also handicap the free burning of the fire.

(b) *No bottom heat in oven.*—If the oven shows evidence of having insufficient bottom heat, check to see that the range has been properly cleaned of soot and ash dust, especially on the bottom side of the oven. See that the direct draft damper, the ventilator register, and the clean-out door are closed.

(c) *Insufficient oven heat.*—If the entire oven does not heat sufficiently, check as in (b) above. Also check the oven door to see that it fits flush with the front sheet.

(d) *Insufficient hot water.*—If there is not sufficient hot water, check as in (a) above; check fire level; check to see that there is no accu-

THE ARMY COOK

mulation of ashes against the water back; and check to see that no hot water faucets are leaking in the sink.

(e) *Oven overheated.*—If the oven becomes overheated, it can be corrected by opening slightly the ventilator register. Closing or partially closing the draft door register will also help to reduce oven heat.

(f) *Heating surface of range too hot.*—If the heating surface of the range is too hot, close the draft door register. Check to see that the ashpan fits flush with the front sheet, and that it does not allow air to enter through the ash pit.

c. *Other ranges.*—(1) *Army field range.*—See paragraph 77.

(2) *Electric.*—The chief point to consider in using electric ranges is to avoid damage to the heating elements through rough handling and spilling of food on the range or heating elements. Any food spilled should be cleaned off immediately.

(3) *Gas.*—If foods are spilled on the burners of gas ranges, the holes will close up, thus cutting off heat. The burners should be kept clean. If the gas range does not appear to be heating well, the matter should be reported for the attention of a plumber who may be able to effect improvement by adjusting the air supply to the burners.

d. *Utensils.*

* * * * *

[A. G. 300.7 (5-19-43).] (C 2, 18 June 1943.)

BY ORDER OF THE SECRETARY OF WAR:

G. C. MARSHALL,
Chief of Staff.

OFFICIAL:

J. A. ULIO,
Major General,
The Adjutant General.

TECHNICAL MANUAL

THE ARMY COOK

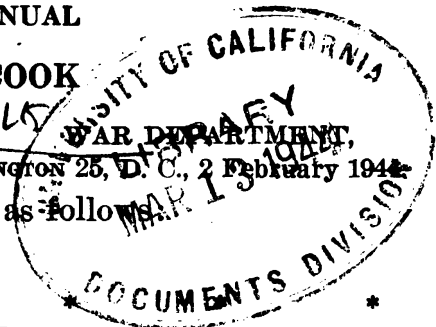

CHANGES }
No. 3 }

WASHINGTON 25, D. C., 2 February 1944

TM 10-405, 24 April 1942, is changed as follows

15. Storage of foods.

* * * * *
b. Refrigeration—temperature, humidity, air motion.

(3) Care should be * * * the air circulation. Containers should be staggered to permit circulation of air. Cold air is * * * the storage space.

c. Operation of refrigerators.

(10) (Added.) Never leave perishable foods such as meat, fish, and milk out of the refrigerator longer than necessary.

(11) (Added.) When foods are to be kept more than 24 hours in a refrigerator, the temperature should be maintained under 50° F.

(12) (Added.) Do not stack fresh unfrozen meat. When two fresh meat surfaces are in close contact their surfaces darken and spoil quickly.

(13) (Added.) Use the coldest place for foods that are most perishable. This applies particularly to fresh pork and variety (organ) meats.

(14) (Added.) Keep left-over cooked meats under refrigeration. Even though meat has been cooked it is still perishable.

(15) (Added.) Use covered containers for foods that absorb odors. Foods that absorb odors should be kept away from foods with strong odors.

* * * * *

[A. G. 300.7 (7 Jan 44).] (C 3, 2 Feb 44.)

18. Meat cutting.

* * * * *
c. Kinds of tools.—With few exceptions, the following tools will fill just about every meat cutting and carving need:

- | | |
|----------------------------------|-----------------------------|
| Brush, meat block, wire. | Knife, cook's, 12'' blade. |
| Cleaver, butchers', 8'' blade. | Saw, butchers', 22'' blade. |
| Fork, cook, flesh, 2-tine, 15''. | Scraper, dough, 6''. |
| Fork, cook, flesh, 2-tine, 21''. | Steel, butchers', 10''. |
| Knife, boning, 6'' blade. | Stone, sharpening. |
| Knife, butchers', 10'' blade. | |

*This change printed as a pamphlet to conserve paper and printing and to expedite delivery to the field.

* * * * *

e. (Added.) *Care of meat blocks.*—(1) Clean cutting block or table after each use. The block will be much easier to keep clean if blood and moisture from meat are not given a chance to soak deeply into the wood.

(2) Use steel scraper and wire brush to clean block. These two accessories are necessary to keep cutting surface of block clean and sanitary.

(3) Scrape and brush block thoroughly at end of day's work, This will remove most of the moisture and allow the block to dry out overnight. It assures an odorless, clean surface for cutting.

(4) Keep cutting head of block dry. Moisture from fresh meat, brine, and blood soak into the wood, causing the block to expand and the wood to soften. This also affects the strength of glued joints. Therefore:

(a) Do not wash cutting surface of block.

(b) Do not wash meat tools on top of block.

(c) Do not allow fresh moist meat to lie on block longer than necessary.

(5) Maintain same bevel on edges of block that it had when new. This will prevent splitting and chipping of outside boards.

(6) Turn block weekly. Every part of cutting surface will then wear down evenly.

[A. G. 300.7 (7 Jan 44).] (C 3, 2 Feb 44.)

65. Beverages.

* * * * *

a. Coffee.—(1) *Rules for making.*—In brewing coffee * * * be strictly observed:

(a) Use fresh roasted and ground coffee which has been kept in a container as airtight as possible, hindering the loss of flavor and strength. Roasted and/or roasted and ground coffee may be considered as a perishable commodity and should be handled as such.

(b) Carefully measure quantities of both water and coffee.

* * * * *

(e) *Never make more than enough coffee for one meal.*—Warmed-over and left-over coffee is bitter and has lost its aroma. However, any left-over coffee need not be wasted; it can be served as iced coffee at a subsequent meal.

(f) *Use ground coffee only once.*—Coffee grounds from which coffee has been made should always be thrown away. Never use them the second time. Coffee made from them is sure to have a bitter and unpleasant flavor. This is true even if fresh roasted coffee and old grounds are mixed. To mix fresh coffee and old grounds is a waste, not a saving.

(g) *Scour coffee pot.*—Unless thoroughly scoured and rinsed daily, some of the spent grounds and oils of the coffee will stick in the corners of the pot and impart a disagreeable taste to subsequent brews. **Do not use this utensil for any other purpose.**

(h) *If bags are used, they should not be dried, neither should they be washed in hot water.*—Hot water cooks in the coffee stains throughout the bag and, in subsequent brews, imparts a bitter and off flavor to the coffee. After the bag is rinsed in cold water, submerge it in cool or cold water until time to use it again.

(2) *Coffee for cooks, guard, and small detail.*—It is the * * * the mess table. Every mess should use a small utensil for the purpose of providing good hot coffee for the kitchen detail, members of the guard, etc., who desire coffee earlier or later than the regular serving time for the organization. In making small quantities, use a tablespoonful of ground coffee to each cup of water and add 1 tablespoonful for the pot.

(3) *Proper quantities* (superseded).—Seven and one-half gallons of coffee are sufficient for 100 men for one meal. This requires 7½ gallons of water and 3 pounds of fresh roasted and ground coffee. This proportion of fresh roasted and ground coffee and water should be used, regardless of the method of preparation.

(4) *Methods of brewing.*—(a) (Superseded.) *Kettle method.*—Bring freshly drawn cold water to a boil. Place roasted and ground coffee in 50-pound muslin coffee bag, sugar or flour bag, or other similar bag in the ratio of 1 pound of coffee to 2½ gallons water, leaving sufficient room in the bag to permit free circulation of water through the bag as well as expansion of coffee. Then tie the bag with cord sufficiently long to be fastened to handle of container or elsewhere to assist in its final removal from the brew. Not more than 15 pounds of ground coffee should be placed in one bag, as more would interfere with the expansion of the coffee. For example, if 100 gallons of coffee are required, place the necessary 40 pounds of ground coffee in three separate bags. This will expedite the extraction and facilitate the removal of the water-soaked bags of spent grounds, after completion of the brew. Place the bag containing the coffee in the boiling water, immediately moving container to back of the stove in order to reduce temperature of water. Never boil coffee. Submerge bag containing coffee with stick or paddle. Push bag up and down in water forcing water to pass through the grounds. Lift bag out of brew in 12 to 15 minutes, permitting surplus water to drain into kettle and remove entirely. Serve coffee at once. Watch temperature of coffee. Be sure to keep it hot without permitting it to boil. The bag containing the grounds should immediately be emptied, washed thoroughly in cold

water, and kept submerged in a pan of cold water until it is to be used again. Do not wash it with soap and never permit it to dry. Keeping the bag wet keeps it sweet. Use a fresh bag each time you receive a new batch of coffee, which should be at least once a week.

(c) *Filtered or drip coffee.*—This is made * * * the ground coffee. This type of utensil is sold under various trade names as "Tricolator," "Filtrator," etc. Place the filter paper in the bottom of the center compartment, add the ground coffee and cover with the perforated metal cover which is usually provided; then pour in boiling water. When all the * * * coffee to boil.

(d) (Added.) *Urn method.*

1. When properly operated, good coffee can be brewed in urns by using urn bags, Tricolator, Dripolator, or other brewing devices. But usually equipment of this kind does not produce good coffee unless used to its normal capacity. It does not provide the flexibility to conform with varying troop strength.
2. Small batches of 5 gallons of coffee cannot be made satisfactorily in equipment designed to make large 20- or 40-gallon batches. In such cases the insufficient quantity of dry ground coffee in relation to the diameter of the dry coffee compartment allows the water to go through it too quickly, resulting in a weak brew. On the other hand, if the diameter of a drip device is too small for the amount of dry coffee used, the depth of grounds in the device retards the free flow of water so that overextraction results.
3. When too much ground coffee is used in a device too small for the quantity of the intended brew, the operation will be delayed from a normal 15 to 20 minutes dripping period to one of an hour or longer; also complete stoppage of filtration may result. This stoppage may cause an overflow of water directly into the urn crock—water that does not go through the coffee at all. This would produce a weak brew. An overflow may also cause a water seal to form where the drip device rests on the urn, creating a back pressure within the urn crock entirely stopping further filtration.
4. Some urns originally equipped with water spreaders to spray water over an urn bag are being used with aluminum drip devices. However, as the water spreader interfered with the placement of the drip device, the spreaders have been removed leaving only a short pipe as a hot water supply. In large urns the short pipe only saturates the

coffee nearest to the water flow while the balance of the charge remains dry, therefore unextracted. There is also a probability that replacement parts or accessories may not be easily obtainable, further interfering with the proper functioning of urns.

5. Some devices will only function satisfactorily when their component parts are securely interlocked into proper position. Due to natural wear or mishandling, this may no longer be possible. Such devices should be immediately repaired or replaced as they may intermittently function properly or clog up entirely, resulting in no coffee being available at mealtime.
6. When any of the foregoing difficulties occur, a good brew of coffee can be made in an urn by using a bag containing ground coffee as described in the kettle method in the same ratio of 1 pound of coffee to each $2\frac{1}{2}$ gallons of boiling water, as follows: Put the bag containing the coffee into the urn. When water in a pressure boiler actually boils, the safety valve will blow off steam. In a gravity urn a thermometer will indicate the boiling point, 212° F. When boiling point is reached, measure required amount of water into urn. This can be done by drawing water out of the boiler and pouring into urn, or if siphon is used the amount of water transferred to urn can be measured by watching the water gauge on the boiler. While the water is being added, stir bag containing grounds with stick or paddle. Push bag up and down forcing water through the grounds. Raise the bag out of brew in 12 to 15 minutes, permitting surplus water to drain into the urn and then remove entirely. Serve coffee at once. Clean the urn bag, using the method described under kettle method.

(e) (Added.) *Emergency kettle or pot method (not to be used in urns).*—Sometimes a bag may not be available. In this case ground coffee in proper proportion to water is poured into the kettle or pot when water reaches the boiling point after which the utensil is moved to back of stove in order to reduce the temperature of the water. During brewing period of 10 to 12 minutes coffee should be stirred occasionally, after which a small quantity of cold water sprinkled into the brew will settle the grounds. This, however, will interfere with the use of a faucet if utensil is so equipped; therefore, operator should ladle out the coffee being careful not to stir up the grounds. Never use loose coffee in an urn due to difficulty in removing grounds from a stationary installation.

(f) (Added.) *Coffee, iced.*—Iced coffee should be made exactly as hot coffee, but twice as strong, viz: 2 pounds of coffee to 2½ gallons of water to compensate for the dilution that will result when ice is added. This does not mean, however, that 7½ gallons of double-strength coffee should be brewed to serve iced coffee to 100 men. It means that 3 pounds of coffee should be brewed with, say, 4 gallons of water, after which the melting of 25 pounds of ice will supply the required balance of liquid needed per mess.

b. *Tea.*

(3) (Superseded.) One ounce of tea per gallon of water has proved satisfactory for hot tea. This quantity will not be exceeded.

(4) One and one-half ounces of tea per gallon of water has proved adequate for iced tea. This includes the water resulting from the melting ice. This quantity will not be exceeded. Iced tea should be served in preference to hot tea when temperature conditions permit.

(5) Bring the required quantity of water to a boil. Place the dry tea in a clean cotton bag, tie the top, and drop the bag into the boiling water. Tea expands in the water, therefore, leave plenty of room in the bag for expansion. Allow the bag of tea to remain in the water for 5 or 7 minutes, then remove it. If tea leaves are allowed to remain in the water longer than 7 minutes the tea becomes stronger and bitter. Agitate the bag of tea three or four times during the period it is in the water. Stir the tea just before serving, to equalize strength throughout. If not stirred the tea on the bottom of the container will be stronger than that on top. Unlike coffee, tea may be made several hours before serving, if kept in earthenware or glass containers, as it does not lose its flavor and aroma. If lemons are available, they may be sliced and served with the tea in lieu of milk, for those desiring this.

(6) Tea to be used as an iced drink should be made in concentrated form. Use the total required quantity of tea leaves, and one-fifth the required amount of water. Prepare the same as hot tea, but a sufficient time in advance to permit cooling. Just before serving, add the remainder of the water, either cold water or chipped ice or a combination of the two, and stir vigorously in order to equalize strength throughout. Added lemon materially improves the flavor.

[A. G. 300.7 (7 Jan 44).] (C 3, 2 Feb 44.)

71. **Cooking—definite plan of work.**—*a.* This plan originates * * * of the food. Each step requires careful planning so that the maximum nutritive value of the foods is retained, the meals are served as attractively as possible, and the work in the kitchen will proceed efficiently and without confusion.

(1) *Beef and what to serve with it.*

Beef cut	Soup or appetizer	Starchy food	Other vegetable	Bread, rolls, etc.	Accompaniment	Salad	Dessert
Roast	Corn chowder Split pea Vegetable	Browned pota- toes Mashed pota- toes Boiled pota- toes	Fresh lima beans Fried egg- plant Asparagus	Parkerhouse rolls Bread Soft bun bread	Yorkshire pudding Sage dressing Pickles	Lettuce Apple and celery Sliced tomato	Lemon pie Ice cream and cake Peach short- cake
Pot roast	Cream of celery Tomato Potato	Boiled noodles Baked potatoes Fried hominy	Stewed toma- toes Kidney beans Glazed par- snips	Bread Cheese bis- cuits Hot rolls	Horseradish Chili sauce Pickled onions	Cabbage and apple Cucumber and onion Banana	Stewed atri- cots Baked custard Butterscotch pudding Cocoanut cream pie Chocolate pudding Baked apples
Steak	Cream of asparagus Bean Chicken	French fried potatoes Escalloped potatoes Hashed brown potatoes	Fried onions Cauliflower Baked corn	Pan rolls Sour milk biscuits Bread	Pickled beets Carrot sticks Celery	Combination Sliced cucum- ber String bean	
Stew	Clam chowder Tomato, con- some	Rice Boiled potatoes Macaroni	Onions Carrots Rutabagas	Corn bread Whole wheat bread White bread Rye bread White bread Hard rolls	Piccaililli Radishes Spiced crab apples Mustard sauce Dill pickles Marmalade	Fruit Pimiento Raw vegetable	Layer cake Rice pudding Fruit and cookies Fruit jello Banana pud- ding Gingerbread
Corned beef	Fruit juice Rice and tomato Barley Cream of spinach	Boiled potatoes Parslied pota- toes Buttered noodles Creamed pota- toes	Boiled eab- bage Buttered carrots Turnips Buttered beets String beans Summer squash			Celery Pineapple Carrot and raisin	
Hamburger steak	Lima bean Potato and carrot Cream of corn	Fried potatoes Au gratin po- tatoes		Hot biscuits Raisin bread Graham bread	Catsup Green onions Jam	Cole slaw Lettuce and egg Beet	Bread custard Chocolate pie Doughnuts

THE ARMY COOK

(2) *Veal and what to serve with it.*

Veal cut	Soup or appetizer	Starchy food	Other vegetable	Bread, rolls, etc.	Accompaniment	Salad	Dessert
Roast	Puree of bean Green pea Consomme	French baked potatoes Baked sweet potatoes Mashed pota- toes	Mashed squash Succotash Steamed spinach	Bread Hot rolls Baking pow- der biscuits	Sweet pickles Raspberry jam Olives-celery	Tomato and cucumber Cabbage and pineapple Celery and nut	Cherry pie Brown betty Chocolate ice cream
Cutlets or chops	Noodle Barley and tomato Vegetable Lentil Chicken and rice Cream of tomato	Escalloped potatoes Candied sweet potatoes Potato cakes Curried rice Dumplings Boiled potatoes	Harvard beets Carrots and peas Wax beans Carrots and onions Peas Braised celery	Bread Parkerhouse rolls Finger rolls Bread Crusty rolls Graham bread	Cranberry sauce Tomato sauce Mushroom sauce Currant jelly Mustard pickles Sliced toma- toes	Peach and cot- tage cheese Lettuce Asparagus Pickled beet Green vege- table Fruit	Butterscotch pie Cottage pudding Orange ice Apple cobbler White layer cake Tapioca pudding

(3) *Lamb and what to serve with it.*

Lamb cut	Soup or appetizer	Starchy food	Other vegetable	Bread, rolls, etc.	Accompaniment	Salad	Dessert
Roast or loaf	Tomato juice Julienne Puree of carrot	Mashed sweet potatoes Parslied potatoes Browned potatoes	Baked onions Mashed tur- nips Fritter-fried eggplant	Parkerhouse rolls Bread Soft bun bread	Mint sauce Mint jelly Assorted pickles	Macedoine of vegetables Carrot and pineapple Lettuce and radish	Ice cream and cake Peach pie Cornstarch pudding

Public Domain, Google-digitized / http://www.natnitrust.org/access_use#pa-90000

Lamb cut	Soup or appetizer	Starchy food	Other vegetable	Bread, rolls, etc.	Accompaniment	Salad	Dessert
Chops or patties	Rice Beef bouillon Onion	Lyonnise potatoes French fried potatoes Spanish rice Steamed rice Baked noodles Boiled potatoes	New peas Butter beans Glazed carrots	Sandwich buns Raisin bread Hot rolls	Tart jelly Celery-onions Mint ice	Bacon-combination Waldorf Sliced tomato	Berry short-cake Custard pie Cantaloupe
Stew	Puree of green pea Potato chowder Fruit cocktail	Boiled kidney beans Swiss chard Buttered cabbage	Hot biscuits Corn bread French bread	Spiced beets Radishes Sour pickles	Prune and carrot Vegetable Pear and grated cheese	Bread pudding with chocolate sauce Berry pie Apricot tapioca	

(4) *Pork and what to serve with it.*

Pork cut	Soup or appetizer	Starchy food	Other vegetable	Bread, rolls, etc.	Accompaniment	Salad	Dessert
Roast	Beef broth Cream of cabbage French onion	Whipped potatoes Buttered diced potatoes Sweet potatoes French baked potatoes Cottage fried potatoes Baked potatoes Boiled potatoes French fried sweet potatoes Mashed potatoes	Escalloped tomatoes Steamed spinach Broccoli Cabbage au gratin Glazed carrots Green peas	Bread Hot rolls Raisin bread	Apple sauce Brown gravy Tart jelly	Head lettuce Cole slaw Banana and nut	Lemon ice Custard pie Baked pears
Chops	Macaroni Clam juice Chicken and rice	French bread Parkerhouse rolls Graham bread	Sauerkraut Swiss chard Creamed celery	Fried apple rings Marmalade Celery	Pineapple and celery Sliced tomato Combination	Cherry dumplings Orange jello Spice cake	
Spareribs	Cream of celery Tomato Puree of split pea	Corn bread Hot biscuits Rye bread		Apple stuffing Barbecue sauce Sliced onions	Fresh fruit Cabbage and green pepper Beet and cucumber	Lemon cream pie Fresh fruit and cookies Caramel custard	

THE ARMY COOK

Baked ham	Corn chowder Bean Sauerkraut juice	Candied yams Spanish rice Buttered hom- iny	Steamed cab- bage Green beans Asparagus	Vienna bread Muffins Bread	Raisin sauce Jelly or jam Radishes- green onions	Raw vegetable Pineapple and cottage cheese	Chocolate ice cream Apricot pie Fresh fruit and cookies
Boiled ham	Lentil Tomato and rice Julienne	Mashed sweet potatoes Parslied pota- toes Escalloped po- tatoes	Corn pudding Black-eyed peas Spinach	Soft bun bread Pan rolls Rye bread	Mustard pickles Spiced crab apples Horseradish sauce	Lima bean Apple and date Onion and cu- cumber Cabbage and peanut	Banana cream pie Pineapple ice Fruit jello
Ham slice	Pineapple juice Vegetable Cream of as- paragus	Fried corn meal mush Baked potatoes Curried rice	Baked corn and toma- toes Fresh lima beans Creamed car- rots	Sour milk bis- cuits Bread Sandwich buns	Sweet pickles Cottage cheese Onion gravy	Apple, celery and nut Hearts of let- tuce Tomato	Rhubarb pie Cocoanut cus- tard Lemon loaf cake
Sausage	Purée of po- tato Noodle Macaroni and tomato	Creamed pota- toes Baked sweet po- tatoes Fried potatoes	Hot spiced beets Squash Escalloped onions	Corn bread Bread Hard rolls	Browned pine- apple Milk gravy Watermelon pickles	Green bean Carrot and raisin Spinach and hard-cooked egg	Apple pie Chocolate cake Chilled melon

(5) *Miscellaneous meat dishes and what to serve with them.*

Meat dish	Soup or appetizer	Starchy food	Other vegetable	Bread, rolls, etc.	Accompaniment	Saled	Dessert
Chili	Tomato Cream of potato Beef broth	Buttered diced potatoes Steamed rice Baked potatoes	Kidney beans Broccoli Acorn squash	French bread Hard rolls White bread	Pickled beets Dill pickles Carrot sticks	Green pepper Lettuce and tomato Celery and raisin	Jello and oat- meal cookies Cocoanut layer cake Berry pie Apricot brown betty Pineapple tapioca Strawberry shortcake
Frankfurters	Oyster stew Split pea Cream of corn	Hot potato salad Spanish rice Baked macaroni	Steamed sauerkraut Asparagus Red cabbage	Rye bread Sandwich buns Bread	Barbecue sauce Mustard Catsup	Cabbage and pineapple Beet and onion Sliced tomato	

(5) *Miscellaneous meat dishes and what to serve with them—Continued.*

Meat dish	Soup or appetizer	Starchy food	Other vegetable	Bread, rolls, etc.	Accompaniment	Salad	Dessert
Meat loaf	Consomme Purée of white bean Tomato juice	Lyonnaise potatoes Hashed in cream potatoes Curried rice Buttered noodles Candied yams Fried potatoes	Black-eyed peas Fried egg-plant Creamed onions Boiled onions Fried corn Escaloped tomatoes	Finger rolls Graham bread Corn bread	Spanish sauce Chili sauce Mustard pickles	Fruit Combination Carrot, prune and celery	Jelly roll Coffee ice cream Peach cobbler
Heart	Navy bean Vegetable chowder Onion	French fried potatoes Potatoes in jackets Steamed brown rice	Hot slaw Lima beans French fried onions	Parkerhouse rolls Baking powder biscuits Bread White bread Raisin bread Hot rolls	Sage stuffing Spiced gooseberries Currant jelly	Cole slaw Asparagus Combination fruit	Apricots and brownies Prune whip Raisin pie
Liver	Tomato juice Spring vegetable Celery	French fried potatoes Potatoes in jackets Steamed brown rice	Hot slaw Lima beans French fried onions	White bread Raisin bread Hot rolls	Bacon Pickled onions Assorted pickles	Pineapple and cheese Endive Banana	Pumpkin pie Peaches and cream Cup cakes
Tongue	Noodle Sauerkraut juice Beef broth with rice	Boiled potatoes Mashed potatoes Escaloped potatoes	Steamed spinach Wax beans Braised celery	Rye bread Hard rolls Bread	Raisin sauce Spanish sauce Horseradish	Spiced beet Pineapple Lettuce	Chocolate pudding Mince pie Ice cream with fruit sauce
Assorted cold meats	Clam chowder Bean purée Onion soup- au gratin	Potato salad Macaroni Creamed whole potatoes	Okra and tomatoes Beet greens Succotash	Cheese biscuits Bread Parkerhouse rolls	Sweet pickles Sliced cheese Mustard pickles	Shredded lettuce Fruit String bean and celery	Apple turn-overs Rhubarb sauce and cookies Cottage pudding

[A. G. 300.7 (7 Jan 44).] (C 3, 2 Feb 44.)

By ORDER OF THE SECRETARY OF WAR:

OFFICIAL:

J. A. ULIO,

Major General,

The Adjutant General.

G. C. MARSHALL,

Chief of Staff.

THE ARMY COOK

CHAPTER 1. Fundamentals.	Paragraphs
SECTION I. General -----	1-4
II. Elements of nutrition-----	5-12
III. Foods-----	13-50
IV. Practice of cooking-----	51-65
V. Rations-----	66-69
VI. Kitchen management-----	70-75
VII. Field cooking-----	76-82
CHAPTER 2. Recipes.	
SECTION I. General -----	83-84
II. List of recipes.	Page
Breakfast dishes (1 to 13)-----	147
Soups (14 to 45)-----	157
Meat dishes (46 to 120)-----	164
Gravies and sauces (121 to 135)-----	184
Fish and seafood dishes (136 to 142)-----	187
Vegetable dishes (143 to 211)-----	189
Deserts (212 to 263)-----	205
Sweet dough products (264 to 271)-----	221
Hot breads (272 to 277)-----	225
Cakes and rolls (278 to 285)-----	227
Salads and dressings (286 to 311)-----	229
Beverages (312 to 315)-----	235
APPENDIX. Tables and useful information -----	237
INDEX -----	257

CHAPTER 1

FUNDAMENTALS

SECTION I. General -----	Paragraphs
II. Elements of nutrition-----	1-4
III. Foods-----	5-12
IV. Practice of cooking-----	13-50
V. Rations-----	51-65
VI. Kitchen management-----	66-69
VII. Field cooking-----	70-75
	76-82

*This pamphlet supersedes TM 10-405, June 9, 1941.

SECTION I

GENERAL

	Paragraph
General	1
Importance of cooking	2
Purpose of cooking	3
Cooking defined	4

1. **General.**—Cooking is the art of preparing food to retain the maximum nutritive value, while improving digestibility and palatability, to the end that the soldier will enjoy his meals and still be adequately nourished. Effective cooking takes into consideration the characteristics of cereals, vegetables, fruits, spices, and meats; the nutritive value and how to retain it; changes that occur in texture and flavor; the functions of foods; and the possibilities of combining one food with another to obtain variety and increased palatability. As a cook gains experience, he learns to bring out attractive flavors by blending and seasoning foods, and to complete his cooking just before the food is to be eaten to preserve its attractiveness and nutritive value. The cook's work is not finished when he has cooked the food; he must also learn to serve it in an attractive manner. This he learns to do by experience. There is no limit to what can be done to improve a mess by thought and care in seasoning, attractive serving, and inventing new combinations and mixtures of foods. The pleasant task of cooking becomes doubly interesting to the cook who is not satisfied with merely cooking well, but takes advantage of every opportunity of finding new and pleasing ways to prepare foods. To him cooking is not just a task—it is a pleasure.

2. **Importance of cooking.**—*a.* Good cooking is recognized the world over as a fine art, and a good cook always commands respect. Cooks who perfect themselves in their art are always in demand, and many have acquired wealth and fame. The Army cook holds a responsible position, as the health and contentment of troops depend largely on the quality of the cooking for their mess. A good cook takes pride in serving appetizing meals, in keeping himself and the kitchen clean and sanitary, and preventing waste. When he takes an interest in his duties and constantly turns out the best possible meals, it will promote health, contentment, and pride of organization in each soldier. On the other hand, poorly cooked meals will do more to make soldiers discontented than any other factor.

b. Food is a human need, and supplying meals frugally and well must continue to rank as an art worth mastering by any Army cook. That is why the Army maintains schools for training cooks, and why

attendance at these schools has become popular. There is a difference between providing passable meals and meals that bring words of praise from the members of the mess. Every healthy man is highly pleased with a dish prepared by a master hand and is quick to praise the man who made it. As the cook gains experience and uses his imagination, he is able to produce each day culinary triumphs surpassing those of the day before. The same old dishes served in the same old way day after day may be entirely wholesome at all times, but they fail to arouse the interest of those who meet them at the table. On the other hand, more than any other factor, poorly cooked meals will breed discontent and will lower morale.

3. Purpose of cooking.—Some food is cooked to make available a greater portion of nutritive value, to make it digestible and palatable through the development of new flavors, and to destroy micro-organisms.

4. Cooking defined.—Cooking is the art of preparing food for the nourishment of the body. In its modern aspect, cooking is both an art and a science. It is an art because it requires special skill in design, color, attractive form, and service. It is a science because exact knowledge is necessary in determining the correct time and amount of heat needed by the food material to preserve maximum nutritive value and to make it palatable and digestible, and thus aid in the accomplishment of an adequate diet.

SECTION II

ELEMENTS OF NUTRITION

	Paragraph
General	5
Energy foods	6
Proteins	7
Minerals	8
Vitamins	9
Water	10
Summary	11
Functions of food	12

5. General.—Good health depends to a great extent on the kind and amount of food eaten. The right food will provide: heat and energy, material for building and repairing the body, and material for regulating body processes. All foods contain some nutrients (carbohydrates, fats, proteins, minerals, or vitamins) that contribute in different ways to the needs of the body. No single food provides all the essential nutrients. For this reason, a wide variety should be selected so that a balanced diet will be assured. A diet to be satis-

factory must first be palatable. Good cooking and pleasing flavor, therefore, are important for good nutrition.

6. Energy foods.—The body must have sufficient energy to meet the daily expenditure for work. This energy is supplied by the oxidation or burning of energy-yielding foods. The energy requirement is spoken of in terms of the number of calories needed daily. A calorie is a unit by which heat or energy is measured (similar to a degree on a thermometer). Muscular activity increases the caloric requirement of the body. An active soldier requires more calories a day than a soldier who is doing office work. Most of the calories come from carbohydrates and fats, but protein also furnishes energy.

a. Carbohydrates.—Sugars, starches, and cellulose (bulk) are the most common forms of carbohydrates. Carbohydrates include all starches (breads and cereals, macaroni and other pastes, rice, potatoes, cornstarch, puddings, etc.), and sugars and sweets (jams, jellies, sirups, candy, cakes, pastries, etc.). In some foods, such as sugar, bread, jams, jellies, or cakes, the carbohydrate is highly concentrated. Even in small amounts these foods are rich in energy. Since carbohydrates tend to satisfy the appetite, it might seem that these foods could be taken to supply the necessary energy in a cheap form. If this were done, the body would get enough energy but would lack other essential nutrients.

b. Fats.—Fats include all the shortenings, butter, cream, salad oil and dressing, bacon, and other fat meats. Fats require a longer time for digestion than do carbohydrates or proteins and therefore are of special importance in delaying the sensations of hunger. A diet devoid of fat is very likely to create an abnormal feeling of hunger a few hours after meals.

7. Proteins.—Proteins must always be supplied in food to provide the material necessary for repairing the wear and tear of the soft tissue and for building new tissue. All proteins are made up of amino acids (building stones), some of which are essential to growth and the maintenance of life. All proteins are not of equal value, for they contain amino acids in different combinations. The proteins that contain all of the essential amino acids are called "complete" proteins. Some proteins containing little or none of some one essential amino acid are called "incomplete" proteins. It is necessary to keep this in mind in selecting the proteins for an adequate diet. It is wise to choose protein from animal sources for the larger part of the protein intake for these are complete proteins. Meat, fish, eggs, and milk products contain proteins of good quality, while legumes, breads, and cereals contain proteins which are less valuable for tissue-build-

ing purposes but useful when combined with animal proteins. Gelatin is an incomplete protein which must be supplemented by another to be as useful as a complete protein.

8. Minerals.—Minerals are present in the foods we eat. The amounts are so small it is impossible to see them but they are absolutely necessary for good health. They may be classified as both protective and building substances. Calcium is the mineral most likely to be deficient in ordinary meals unless thought and action are taken to see that it is supplied.

a. Calcium and phosphorus are necessary for strong, firm bones and teeth, and to maintain the tone of various tissues. The richest sources of calcium and phosphorus are milk, eggs, cheese, and some green leafy vegetables.

b. Iron and copper help promote growth and prevent anemia. Iron and copper are found in liver, lean meat, egg yolk, apricots, green leafy vegetables, and whole grain cereals.

c. Iodine is needed for the proper functioning of the thyroid gland in the throat. Without it, the disease of common goiter may occur. Iodine is found in sea foods and in the water supply and vegetables grown in nongoiterous regions. In goiterous areas iodized salt may be used to supply the necessary iodine.

d. Several other inorganic mineral elements are also essential. They are present in many of the foods people eat and there is little danger of not obtaining enough of them. If milk, vegetables and fruits, lean meats, fish, eggs, whole grain breads, and cereals are included in the daily diet, all of the mineral requirements can be fulfilled.

9. Vitamins.—The vitamins are also minute substances which are essential to life, growth and good health. Without them the body is unable to function properly. They aid in the formation of bone and teeth, the maintenance of the integrity of the tissues, and the utilization of food. Vitamins aid the minerals in body-building and are protective substances.

a. Vitamin A aids in maintaining a healthy condition in the respiratory, digestive, and urinary tracts, and is essential for good eyesight. Foods that are major sources of vitamin A are liver, milk, and other dairy products (especially summer butter), and leafy green and yellow vegetables. It is the coloring matter, carotene, of the latter foods, which is changed by the body into vitamin A. Vitamin A, or carotene, is readily destroyed by exposure to the oxygen of the air and by heat. It is important, therefore, to utilize fresh leafy green and yellow vegetables as soon as possible.

b. Vitamin B as it was originally discovered is now referred to as the "Vitamin B complex" because it has been found to be made up of several vitamins. Vitamins of the B complex are likely to be lacking in the average diet unless an effort is made to see that they are included. They are water-soluble and may be lost by soaking in water or discarding the liquid in canned goods. Some of them are readily destroyed by heat when food is cooked too long.

(1) Vitamin B₁ (thiamine) aids in the utilization of carbohydrates and stimulates a good appetite.

(2) Vitamin B₂ (riboflavin or G) aids in the utilization of food, and helps to keep the skin, hair, and eyes normal.

(3) Niacin (nicotinic acid) is concerned in the prevention of pellagra. The best sources are meats, while legumes, whole grains, and green vegetables also contribute appreciable amounts.

(4) Other recently discovered factors are also part of the vitamin B complex. They are usually present in foods which are good sources of the other B vitamins.

c. Vitamin C (ascorbic acid) helps form strong bones and teeth and helps keep the gums healthy and teeth firm. It is found chiefly in citrus fruits (oranges, grapefruits, etc.), tomato juice, potatoes, cabbage, and other green leafy vegetables. Vitamin C is water-soluble and is readily destroyed by heat and oxygen. The losses in careful cooking may be as much as 40 percent. By careless cooking, the losses may be so great as to impair the adequacy of an otherwise good diet.

d. Vitamin D aids in building sturdy bones and teeth. The best sources of vitamin D are sunshine, irradiated, evaporated, or whole milk, irradiated cereals, butter, and eggs.

10. Water.—Water is essential to all vital processes, including circulation, assimilation, excretion, and body regulation.

11. Summary.—It makes no difference in what part of the country a man may be. Everyone needs to obtain from his daily diet the same five essentials: energy, protein, minerals, vitamins, and water. A diet which lacks any one of these essentials is not balanced. It is only possible to have a balanced diet by serving a variety of foods. The soldier enjoys variety, not only in the foods themselves but in methods of preparing them. He wants foods that appeal to his eyes and his sense of taste and smell; he wants to eat in pleasant surroundings. His food should be wholesome and *good to eat*.

12. Functions of food.

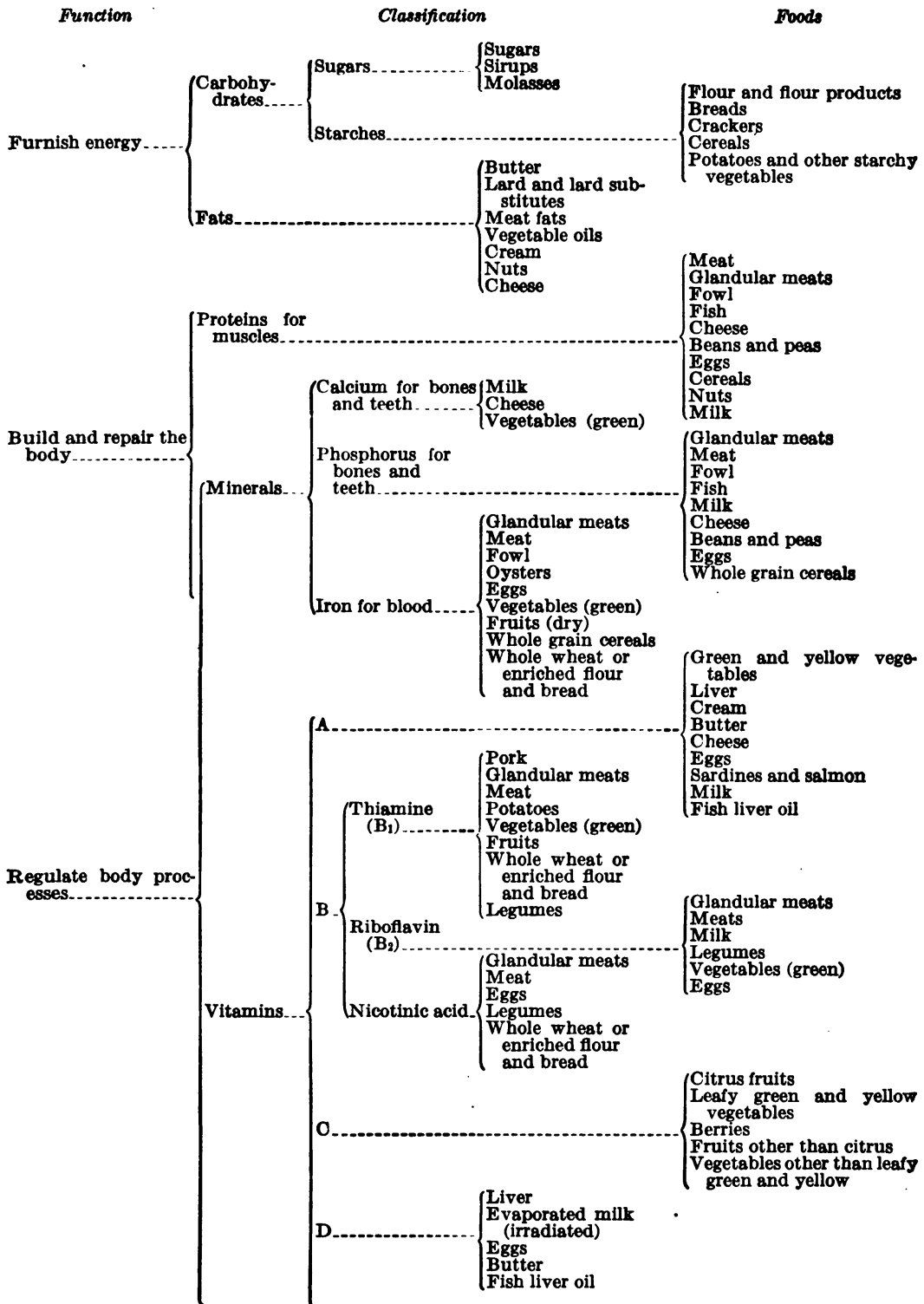

SECTION III

FOODS

	Paragraph
Purchase of foods for mess.....	13
Inspection.....	14
Storage of foods.....	15
Various kinds, qualities, uses, etc.....	16
Meat.....	17
Meat cutting.....	18
Beef.....	19
Beef cutting.....	20
Wholesale market cuts of beef for small messes.....	21
Lamb.....	22
Lamb cutting.....	23
Fresh pork.....	24
Preparing fresh pork.....	25
Smoked meats.....	26
Cutting smoked meats.....	27
Veal.....	28
Cutting veal.....	29
Meat specialties.....	30
Frozen meats and fish.....	31
Sausage.....	32
Fish.....	33
Poultry.....	34
Dairy products.....	35
Eggs.....	36
Canned foods.....	37
Cereals, breakfast.....	38
Beverages.....	39
Condiments.....	40
Corn meal and grits.....	41
Extracts, flavoring.....	42
Fruits and vegetables.....	43
Jams, jellies, preserves, and fruit butters.....	45
Lard and lard substitute.....	45
Macaroni, noodles, and spaghetti.....	46
Dressings, salad.....	47
Sirup.....	48
Sugar.....	49
Tapioca.....	50

13. Purchase of foods for mess.—*a.* The cook is not required to make purchases but may be called on to report what is needed. He must remember that it is not necessary to carry a large stock of food. It is especially important to avoid purchases of large quantities of those foods which spoil readily. Therefore, the cook should become familiar with the keeping qualities of all the foods used in a mess, not only to aid in preventing purchases of too large quanti-

ties but also to insure that foods on hand are consumed before spoiling.

b. All cooks should have a good general knowledge of the keeping qualities of foods. They know that such foods as fresh meats, eggs, fish, milk, butter, most fruits, and many vegetables do not keep long and must be purchased in small quantities and consumed within a short period. They must be on the alert to see that all perishable foods are consumed before they have time to spoil. Allowing foods to spoil is always inexcusable.

14. Inspection.—*a.* Although the quartermaster or veterinary officer inspects all foods when received, this does not relieve mess personnel from the responsibility of inspection when received in the mess. In the absence of the mess sergeant, it becomes the duty of the cook on shift to receive, inspect, sign for, and properly store all food items received, unless other definite arrangement has been made by the organization commander.

b. Mess personnel should see that all food received in the mess is clean, sanitary, wholesome, in full weight and measure, and of the grade required by Government specifications. Food which is decomposed or rotten, insect-infested (wormy), moldy, musty, etc., should not be accepted. While it is not expected that mess personnel be experts in determining whether the grade is that required by Government specifications, whenever it is suspected that food delivered is below the required grade, the matter should be reported to the organization commander. Discrepancies in weight, measure, or count should be noted on the delivery ticket or invoice before the foods are accepted. A few minutes spent in making the proper inspection of foods at the time of delivery will insure receipt of clean, sound, and wholesome food and will result in an annual saving of many dollars to the mess.

c. It is especially important to inspect for condition all highly perishable foods, as meats, fish, poultry, fresh milk, fresh fruits and vegetables, butter, eggs, etc. It is also important to inspect canned foods to see that there are no swelled or leaky cans and to inspect cereals to see that there are no insects or worms present. Examples of foods which should not be accepted are slimy, foul smelling, or bruised meats, fish, and poultry; scabby or rotten potatoes; wilted or badly rusted lettuce; scaly or spotted apples; bruised peaches; swollen or leaking canned foods; and insect-infested or wormy flour or cereals.

d. Accurate scales should be available in every mess. The Government contracts for net weights, that is, the weight of the food with

weight of the container deducted. A mess should not pay for something it does not receive. The weight of wrapping paper, burlap bags, cardboard containers, etc., should be deducted when checking weights.

e. Meat that has spoiled usually has an unmistakable odor. Surface slime results from the growth of bacteria on the surface of the meat and follows exposure of the meat to too high temperature and high humidity. Meat that is kept cold and dry does not become slimy. Surface slime is not always indicative of spoilage. Washing or slight trimming usually removes surface slime and the meat beneath the surface is found to be sound. Sourness (spoilage) near the bone can be detected by the use of a steel trier which is inserted into the meat near the bone and smelled as soon as it is withdrawn. A knife with a polished blade might be used for the same purpose. Deep spoilage may also be detected by cutting the piece of meat in two and smelling the cut surface. Surface mold on meats is not harmful. If mold is extensive and washed or trimmed away it might impart a moldy flavor to the meat, but it is not harmful to health. If any doubt exists as to the soundness of meat, a qualified inspector should be consulted.

f. Spoilage of canned food is generally indicated by swelled cans. The contents of a can with swelled or bulged ends or sides should never be served. Starchy vegetables, as corn, pumpkin, squash, etc., sometimes spoil without swelling the can, but on opening the can the spoiled condition is unmistakable, as the odor and taste are very disagreeable. (See par. 37*d.*)

15. Storage of foods.—*a. General.*—All foods spoil more rapidly at warm temperatures than at cold. This applies especially to highly perishable foods, such as meats, fish, butter, eggs, milk, and certain fruits and vegetables. Excessive dampness contributes to the growth of mold and consequent spoilage.

b. Refrigeration—temperature, humidity, air motion.—(1) The purpose of refrigeration in the mess is to reduce, by means of controlled cold air, the growth and activity of factors which cause spoilage. The refrigerator should be used only for highly perishable items. Products placed in the refrigerator unnecessarily may cause overcrowding and result in poor operation and unsanitary conditions. Foods which are spoiled should never be placed in the refrigerator. Excessive dampness may be caused by poor air circulation or spilled liquid and is as undesirable in the refrigerator as anywhere else.

(2) The mess refrigerator should produce a storage temperature of 50° F. or lower, whether cooled by ice or mechanical means. A lower

temperature is more desirable and 40° F. may be obtained in refrigerators properly designed for that purpose.

(3) Care should be used when storing food in the refrigerator, in order to avoid interference with the air circulation. Cold air is heavier than warmer air, hence the air is naturally circulated downward from the cooling coils or melting ice, and upward through the storage space, continuing to the ceiling where it moves across to the cooling section, is cooled, and again moves downward on another cycle. Good air circulation is necessary to produce a refrigerator temperature of 42° F., which is 10° above the melting point of ice. Larger size refrigerators may be equipped with small electric fans to make the air motion more positive and effective. In this design, the air is drawn upward by the fan, through the cooling section, and discharged across the ceiling where, due to its temperature and weight, it moves downward through the storage space.

c. Operation of refrigerators.—(1) Keep the refrigerator clean by frequent washing and wiping. Thoroughly scrub it out at regular intervals, at least once a week with soap and hot water.

(2) Ice-cooled refrigerators, and so-called wet-coil mechanically cooled refrigerators, are equipped with drain lines to carry away water from melting ice and condensate. Keep the drain pipe open. It should be disconnected and flushed out with hot water once a week to remove accumulations of slime which will form. The drain trap in the floor of the refrigerator should likewise be kept in good working order. Provision should be made to drain away the water outside the kitchen so that insect breeding is minimized.

(3) The doors should fit tightly all around. There should be no uncovered openings in the floor of the refrigerator which will permit the loss of cold air or the admission of insects. If repairs are needed, report the matter.

(4) Keep the refrigerator doors closed as much as possible. Air circulation is disrupted and cold air is lost with each opening of the door.

(5) Do not place food in the ice compartment of an ice-cooled refrigerator. Do not wrap the ice with paper or any other material. This interferes with the air movement over the surface of the melting ice and reduces the air cleansing and refrigeration capacity of the refrigerator.

(6) Hang fresh meat on hooks. Avoid piling. Do not hang meats so that pieces touch each other. Where blood may drip from meat, dishes should be placed underneath. Do not pack vegetables too closely.

(7) Food carried too long will eventually spoil in the best refrigerator. Use all left-over foods as soon as possible. Avoid stocking an oversupply.

(8) The ice compartment of an ice-cooled refrigerator should be kept well filled for best results. It should never be permitted to get below one-third full.

(9) Do not expect any refrigerator to perform efficiently when subjected to abuse of the foregoing rules, or if located in too close proximity to cooking ranges.

d. Mechanical refrigerators.—(1) Mechanically cooled mess refrigerators may be of two different types:

(a) The so-called dry-coil type operates with a cooling unit temperature which is below 32° F., the freezing point of water. Moisture deposits on this surface in the form of frost. Although this type may be adjusted to produce a lower refrigerator temperature, the wide temperature difference between the cooling unit and the air of the refrigerator causes a low relative humidity or dry air. Leafy vegetables, such as lettuce, spinach, and celery may be wrapped in a wet covering to prevent wilting. Products high in moisture content, which may pick up undesirable flavors, may best be placed in covered containers, although it is not considered good practice to tightly cover products consisting of living cell structure, such as fresh fruits and vegetables. Frosted coils should be frequently defrosted by means of shutting down the unit, never by the use of hot water or by scraping or chipping. Accumulations of frost reduce the cooling value of the unit.

(b) The extended surface wet-coil type operates with a cooling unit temperature above 32° F., the freezing point of water. Moisture deposits on this surface in the form of drops of water. An electric fan circulates the air of the refrigerator through this cold, wet surface where the air is cooled and some cleansing effect is accomplished. The excess water is taken off through a drain. Due to the narrower temperature difference prevailing, the relative humidity in the refrigerator is higher and no difficulty should be experienced with wilting or drying out of products. The functioning of this type of refrigerator is quite comparable to a well-designed ice-cooled refrigerator.

(2) Ice cubes are frozen only in the units that operate at a temperature below 32° F., the freezing point of water. The water may absorb undesirable flavors before it is frozen and these may be transmitted when the ice cubes are used in food or drink.

e. Arrangement of food in refrigerator.—(1) The proper grouping of products in mess hall refrigerators will promote sanitation, help to prevent contamination from the absorption of unpleasant flavors, and thus protect the original quality of the product.

(2) Two refrigerators are generally provided in each mess hall. However, when only one is available, it should, if possible, be divided and operated as two separate refrigerators.

(3) Fresh fruits and vegetables give off respiration gases (odors) which in some cases are quite obnoxious. Fluid products, or those high in moisture or fat content, readily absorb odors from other products resulting in off-flavors and loss of quality. Fresh eggs, butter, milk, cream, lamb and veal, etc., are easily damaged in this manner. Likewise, prepared foods, such as coleslaw, salads, gelatin (while liquid), gravies, and sauces are subject to flavor damage. As an example, the wet surface of a cut watermelon will become almost inedible after being placed in a confined space with some fresh fruits and vegetables.

(4) One refrigerator should be used only for eggs, dairy products, fresh meat, and prepared or cooked foods of high moisture content which are not highly odorous.

(5) The other refrigerator should be used for fresh fruits and vegetables and other products prepared or cooked, which are relatively low in moisture content and distinctively flavored.

(6) Products in sealed containers may be placed in either refrigerator without becoming damaged or causing damage to other products. However, it is not advisable to use covered containers for other than cooked or prepared foods.

(7) Some perishable products need not be placed in the mess hall refrigerators. It is seldom that products are carried beyond 2 or 3 days and the general supply room should be entirely suitable for these.

(8) The following is a list of products which *should always be properly placed* in one of the two refrigerators.

(a) *First refrigerator.*

Butter.

Cheese.

Cream.

Fresh eggs.

Fresh meat and meat products.

Milk and buttermilk.

Fresh poultry.

Cold cuts—delicatessen meats.

Cooked or prepared foods (high in liquid content and not highly odorous) such as coleslaw, salads, custards, puddings, liquid gelatin, gravies, sauces, cooked vegetables, cooked fruit, and cooked meat.

NOTE.—All cooked food should be permitted to cool before placing in the refrigerator.

(b) *Second refrigerator.*

Asparagus.	Spinach.
Beans, green or wax, snap.	Summer squash.
Beans, green limas.	Turnips, tops on.
Beets, small, tops on.	Tomatoes, ripe.
Broccoli.	Apricots, ripe.
Brussels sprouts.	Berries.
Carrots.	Cherries.
Cauliflower.	Currants, fresh.
Celery.	Cranberries.
Corn, green.	Figs, fresh.
Cucumbers.	Grapes.
Endive.	Nectarines, ripe.
Lettuce.	Peaches, ripe.
Okra.	Pears, ripe.
Peas, green, pod.	Plums, ripe.
Peppers.	Watermelons, not cut.
Radishes.	

(c) *Smoked meats, etc.*—Uncut smoked meats, such as whole ham, bacon, and bologna are preferably placed with the fruits and vegetables in the second refrigerator. When sliced or with exposed cut surface, the first refrigerator is preferable.

(d) *Ice.*—Where the refrigerators are mechanically cooled and ice is to be carried in one, it is more desirable to place the ice in the second refrigerator. The resulting increased humidity will help keep the products fresh and crisp and the ice is also beneficial in that the melting surface absorbs and carries away to the drains organic gases developed by the products in the confined space.

(9) Following is a list of products which should be kept in the supply room. They need not be placed in a refrigerator as some of them may be damaged or cause damage if placed there. As an example, dry onions may become damp and moldy.

Artichokes.	Bananas.
Apples.	Beets, mature.
Avocados.	Cabbage.

Casabas.	Rutabagas.
Citrus fruits.	Squash, hubbard.
Dates, fresh.	Tomatoes, firm.
Eggplant.	Turnips, large.
Fruits, dried.	Lard and lard substitutes.
Garlic.	Fish, dried, smoked or salted.
Melons, honeydew, cantaloupes.	Glucose, sirups.
Nectarines, green.	Honey.
Onions.	Meat, canned.
Parsnips.	Milk, evaporated, canned.
Pears, green.	Molasses.
Peppers, cured, pod.	Nuts.
Peaches, green.	Oil, cooking.
Plums, green.	Pickles and relish.
Potatoes, white or sweet.	Sirups.
Pumpkins.	

16. Various kinds, qualities, uses, etc.—Army messes use many different foods which are supplied or are available in different forms. Beef is supplied in quarters (fore or hind), wholesale market cuts, or boneless beef, and may either be chilled or frozen; chickens may be broilers, fryers, or roasters; flour may be hard or soft; milk may be fresh, canned, or dried; fruits and vegetables may be fresh, canned, or dried. Most foods may be used in many different ways, either alone or in combination with other foods. The several forms of the same food may each require a different handling. The cook is greatly aided in his work by a thorough knowledge of the foods which he prepares—their kinds, qualities, uses, and nutritive values.

17. Meat.—*a. General.*—Meat is the flesh of any animal used for food. Commercially, it consists of muscle tissue, connective tissue, fat, and bone. Edible glands and organs are also classed as meat, but may be referred to as meat specialities, sundry meats, fancy meats, or variety meats.

b. Kinds of meat.—The kinds of meat are: beet from cattle, veal from calf, pork from hog, and lamb from sheep.

c. Value in diet.—Meat supplies many of the essential food elements necessary to make the diet adequate.

(1) *Protein.*—Meat, containing about 20 percent protein, is a very concentrated source of this important food element. Meat protein is of high quality, as all animal proteins are superior to vegetable proteins.

(2) *Calories.*—All meats contain fats in greater or lesser degree, and have a caloric value varying with the degree of fatness. Some fat is lost during cooking or the visible fat may be cut away before eating,

and so the caloric value will depend upon the method of cooking and the personal preference of the individual.

(3) *Minerals*.—(a) Meat is a valuable source of two of the three minerals (calcium, phosphorus, and iron) in which the average diet is most likely to be deficient. Meat, although not a good source of calcium, is the richest source of phosphorus, which is necessary in the utilization of calcium.

(b) Meat is an excellent source of iron which is in a readily utilizable form. Liver of all types has a higher content of iron than any other food, pork liver containing three times as much iron as beef liver, which is higher than calf or lamb liver. Iron is better utilized when even a very small amount of copper is present. Meat supplies copper, too, which aids in the utilization of iron.

(4) *Vitamins*.—Meats (particularly the glandular organs) are important sources of the B vitamins, among which are vitamin B₁ (thiamine), vitamin B₂ (riboflavin or vitamin G), and niacin (nicotinic acid). Lean pork is especially rich in thiamine. Many of the B vitamins are destroyed by heat. Overcooking is, therefore, to be avoided.

d. Canned meat.—Canned meats are composed almost wholly of lean meat, as most of the fat is trimmed away in preparation for canning. Canned meat is, therefore, a good source of protein, phosphorus, iron, copper, and the B vitamins, but is comparatively low in fuel value.

18. Meat cutting.—*a. General*.—(1) Every mess where meats are cut should be equipped with a set of knives for various purposes; however, meat can be satisfactorily cut with a knife and saw if kept sharp. Butcher knives are best for cutting roasts and steaks. Boning knives, including at least one with a short, narrow blade, are best for removing bones. A saw is needed. A good butcher uses a cleaver very little. A hand meathook is an aid in handling and boning beef. A hook is rather inconvenient to one not accustomed to it, but it becomes indispensable to one skilled or experienced in its use.

(2) A good job of meat cutting cannot be done with dull tools. Saws, knives, and cleavers should be sharp. A butcher's steel is used only to keep the edges of knives straight, not to sharpen them. The sharpening should be done on a grindstone and finished on a smooth whetstone. Saws are sharpened by filing. Frequently the teeth of the saw need setting to give them the proper angle. This requires special equipment. The average person is not competent to set and sharpen meat saws. Retail butchers now rent sharp saw blades from tool supply houses for a nominal charge. As the blades become dull they are exchanged for sharp ones.

b. Uses of tools.—In cutting meat to the best advantage proper tools are needed. Keep in mind that each piece of cutlery was designed to do a certain job, therefore it is advisable for the cook to study his meat cutting tools and use each piece for the work for which it was intended. For example, the short, narrow, stiff blades of boning knives were designed especially for cutting through joints and for cutting close around bones in order to separate them from the meat. Steak knives with long, wide blades were made to cut steaks and roasts. Knives with thin blades, such as the french slicer and roast beef slicer, are best suited for carving cooked meat.

c. Kinds of tools.—With few exceptions the following tools will fill just about every meat cutting and carving need:

- 6-inch boning knife (straight).
- 6-inch boning knife (curved).
- 10-inch steak knife (scimitar).
- 10-inch steak knife (straight).
- 12-inch cook's knife (Sabatier type).
- 12-inch roast beef slicer.
- 7-inch cleaver.
- 12-inch steel (smooth or semismooth).
- 22-inch meat saw.
- Hand meathook.
- Steel fork.

(1) *Knives.*—Sharp knives are essential for efficient work. One way to keep them sharp is to use them only for the work they were intended to do. For instance, a boning knife has a comparatively narrow bevel along the edge. It will stand much more abuse and hard work than a properly ground steak knife, which has a wide bevel and a thin edge. Rule number one should be: "Never use a steak knife for boning meat."

(a) *Sharpening.*—Knives should never be sharpened on a power-driven dry stone since this will remove the temper from the cutting edge. A water stone or carborundum oilstone may be purchased at a reasonable cost. Either of these make good sharpening units. There also are combination units on the market. Some of these contain two stones and some three, each of a different degree of coarseness. The stones are securely fastened together on a revolving shaft. The base of the unit is filled with a light oil.

The knife is first put on a rough stone, then on a smoother one. Use the entire stone for sharpening the knife. In this manner, the stone will not "hollow out" at a particular point. It is best to draw the full blade, from heel to tip, across the full length of the stone

in each movement. Turn the knife over and pull back in the same manner from the opposite end of stone. In this fashion the knife is sharpened evenly and smoothly and the stone is worn uniformly. When the knife has sufficient edge, clean the blade and handle thoroughly before using.

(b) *Steeling*.—After the knife has been sharpened on a stone, use a smooth or semismooth steel to keep it sharp. Imagine putting a razor on a rough steel and you will realize why a smooth steel is better than a coarse one for keeping a keen edge on a knife blade. The following shows the easiest and most effective method of steeling a knife (fig. 1):

1. The steel is used to true the blade and keep the edge in perfect condition. Although there is a technique to handling the steel, it is easily mastered with practice.
2. Hold the steel firmly in the left hand, thumb on top of the handle, with the point upward and slightly away from body.
3. Place the heel of the blade against the far side of the tip of the steel (fig. 1①). The steel and the blade should meet at a slight angle, about 25°.
4. Bring the blade down across the steel toward the left hand with a quick swinging motion of the right wrist and forearm. The entire blade edge should pass lightly over the steel (fig. 1②).
5. Bring the knife into position again but with the blade against the near side of the steel (fig. 1③). Repeat the same motion, passing the blade over the steel.
6. Alternating from side to side, a dozen strokes will true the edge.

Put the knife on the steel as often as the edge needs it. Aim to have the blade sharp always.

(c) *Care of knives*.—Every first-class meatman takes a personal interest in keeping his equipment in number one condition at all times. The sharp edge of a knife, like a razor, can be dulled easily. For that reason knives should never be thrown into a drawer with other tools. A wood strip (1 by 2 by 12 to 20 inches long) can be made secure to the bottom of a table drawer, first sawing notches into it at intervals of 2 to 3 inches. These cuts (notches) should be made about 1¼ inches deep and of such width that a knife blade will fit easily into them. Arranged in order in these notches, the knives are readily available and at the same time the edges are protected. In many instances a knife holder is fastened to the side of

the meat block. This may be handier than the drawer arrangement, but to protect the knives as well as the holder the knife handles should not protrude above the edge of the block. Whatever method

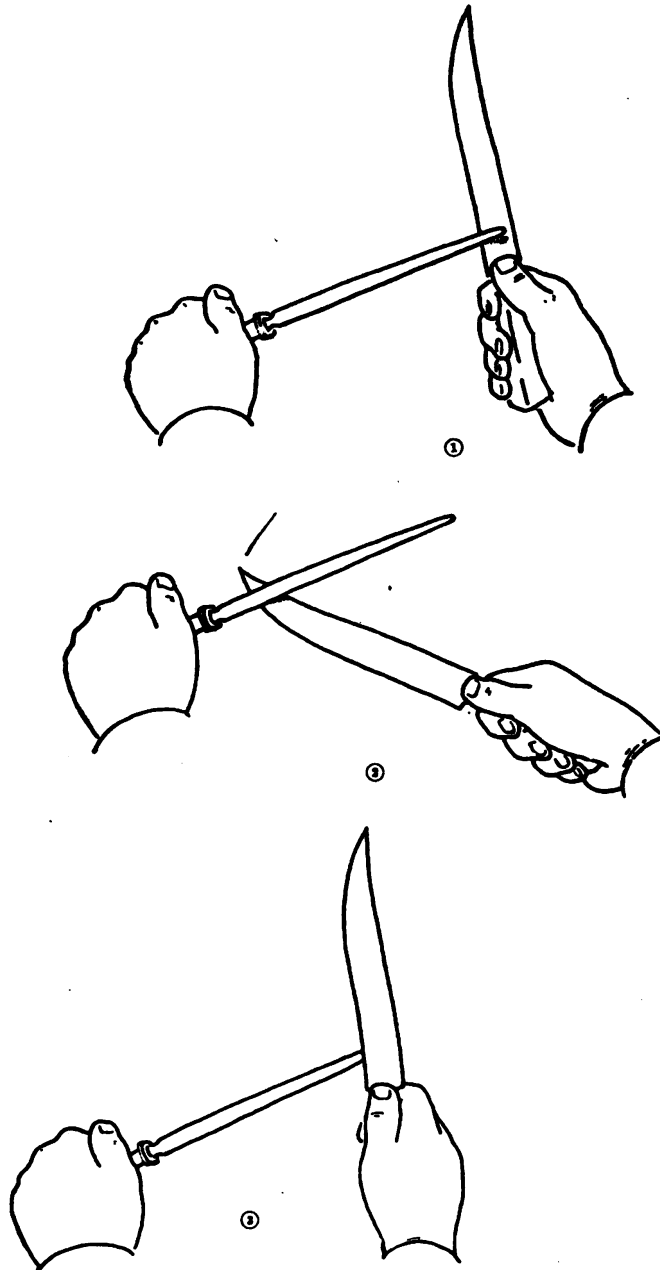

FIGURE 1.—Steeling a knife.

is followed, it is essential that tools should receive the care and attention they deserve. Government specifications provide good knives. If cared for they will give satisfactory service for a long time.

(d) *Responsibility for knives.*—Each cook should have his own tools and the mess sergeant should make him responsible for their care and condition. If this plan is followed the tools are much more likely to be in proper condition at all times. When several men use the same knives there is no incentive for anyone to care for them. As a result they are usually in bad shape. Even though the kitchen has only a limited number of steak and boning knives, they should be divided as equally as possible among the cooks. From the standpoint of getting the work done, one sharp knife is worth more than six dull ones; but until each cook is made responsible for his own tools the Army cannot expect to find sharp knives in its kitchens. At the close of work each man should check his tools with the mess sergeant, who in turn takes charge of them until the cook returns to duty.

(2) *Cleaver.*—Use this piece of cutlery as little as possible. Unless it is very sharp and used properly, the cleaver will shatter the bone and fill the surrounding meat with tiny bone splinters. These splinters not only cause inconvenience in eating but they are dangerous. It may become necessary to rush some man to a hospital because a bone splinter has lodged in his throat.

(3) *Meat hand hook.*—Although a meathook is inconvenient to one not accustomed to its use, it is in reality a valuable aid in boning meat. It not only saves time but it eliminates most of the danger of cutting fingers in the boning operation.

(4) *Metal mesh glove.*—In addition to the meat hook, workers in large packing plants have discovered that a metal mesh finger glove, worn on the left hand, is a good protection against cutting fingers while boning meat. The glove is made of a fine metal mesh which is flexible and interferes in no way with the action of the fingers. It covers the thumb and the first and second fingers. A strap on the wrist holds the glove in place. It is a practical safeguard for anyone who is boning meat.

(5) *Meat saw.*—A saw with a dull blade will not do satisfactory work. Three blades should be available at all times for each saw, one in use and two in reserve. When a blade loses its edge and set, it should be replaced with a sharp one. When two blades are dulled they should be exchanged at the commissary for two sharp ones. Saws are sharpened by filing, and the teeth need to be set occasionally to give them the proper angle to prevent dragging. This requires special equipment. The average person is not competent to set and sharpen saw blades. The standard saw with a 20- to 24-inch blade is best for most commercial purposes. However, the small one issued for field duty will answer in an emergency.

d. Keeping meat tools clean.—(1) Every piece of kitchen equipment, especially that which comes in direct contact with food, must be kept clean. Meat tools are no exception, but as long as wood handles are fastened on metal, as is the case with most knives, cleavers, and saws, the problem of keeping the tools in condition to pass rigid inspection will continue to exist. Regardless of the care exercised in manufacturing the knife, it is impossible to rivet two pieces of wood to a piece of steel and not leave a crack or crevice for dirt to collect. Boiling water is not the solution to the problem. Hot water soaks into the wood, causing it to expand. As the wood dries it shrinks. In a short time the handles are loose and the cracks and crevices are bigger than ever.

(2) A good practice is to fill all the cracks around the handle with plastic wood; then do not let the piece of cutlery lie in hot water. There is no occasion for leaving a knife in water for any length of time. The knife, cleaver, or saw can be kept clean by simply wiping, then rinsing in clean water, and wiping with a dry cloth. The preceding treatment not only will prolong the life of the cutlery, but will help keep it in better shape for inspection.

19. Beef.—*a. Importance in mess.*—Beef is a very important food in the Army mess. It is a universally popular food and forms the main dish of many meals. For these reasons the Army cook should have a good general knowledge of the kind and quality of beef supplied for Army messes and of methods of cutting and use. This information is given in the following paragraphs.

b. Classes of carcasses available.—The classes of carcass beef are steers (males castrated when young), heifers (young females), cows, bulls, and stags (males castrated after they reach maturity).

c. Type of carcasses used.—The carcasses (sides and quarters) desired for Army use are the beef (plump and meaty) type, as distinguished from the dairy (lean and bony) type. Carcasses of the beef type carry a greater proportion of meat to bone, and the flesh is of better quality. Army specifications permit the purchase of carcasses and wholesale cuts from only steer beef. Heifer beef compares very well with steer beef in conformation (shape and plumpness), development of the best cuts, and quality of meat. Steers and heifers are more desirable than any other class of beef.

d. Weight.—A steer carcass used in the Army mess may weigh from a minimum of 450 pounds to a maximum of 900 pounds. Each side will weigh from 225 to 450 pounds. The average 12-rib forequarter represents about 52 percent of the side and weighs from 115 to 235 pounds. The hindquarter, being 48 percent of the side, weighs

slightly less than the forequarter. The difference in weight of the forequarter and hindquarter in a 300-pound side will be about 12 pounds.

20. Beef cutting.—*a. General.*—In cutting beef carcasses consideration is given to the suitability of different cuts for different purposes. Lean beef is not all of the same tenderness. In general, the muscles (lean meat) of locomotion used for work, such as walking and running, are not as tender as the supporting muscles which are found along the back of the carcass. Since the meat differs in tenderness, the object of cutting beef is to separate the less tender meat from the tender; and for the sake of uniform cooking, the thin meat is separated from the thick meat. The less tender wholesale cuts include the chuck, shank, brisket, plate, flank, and round. The tender ones are the rib, short loin, and loin end. All cuts of meat, however, are tender when properly cooked.

b. Division of beef side into wholesale market cuts.—(1) The beef chart (fig. 2) shows the entire side of beef broken into wholesale cuts. This chart is especially valuable since it shows the location of each wholesale cut in relationship to the full side. It will be noticed that the hindquarter includes the round, rump, loin end, short loin, and flank. The forequarter cuts are rib, chuck, shank, brisket, and plate.

(2) Figure 3 shows the location, structure, and names of the bones in a side of beef. The solid lines show the division of the wholesale cuts as illustrated in figure 2. It will be noted that the side of beef has 13 ribs. These are numbered from 1 to 13, beginning at the front end. The hindquarter and forequarter are usually separated between the twelfth and thirteenth ribs. The chuck contains parts of the first 5 ribs. This leaves parts of 7 ribs, from the sixth to the twelfth, inclusive, in the wholesale market rib.

c. Cutting carcass beef.—For the most part, carcass beef, as well as wholesale market cuts, can be used to best advantage in the Army mess if it is first boned. When cut this way the various muscles can be separated and cooked according to the method designed to make them most tender and palatable. In addition, the boneless cuts will be easier to carve after they are cooked. A great deal of study was given to developing the method of cutting described in the following paragraphs. Dozens of carcasses of beef were cut up in every conceivable manner in order to develop a style that would be easy to follow, and at the same time would provide a maximum number of good solid pieces of meat suitable for a variety of cooking methods. It is recommended, therefore, that the Army cook follow carefully the instructions given here in order to get the greatest amount of

BEEF CHART

LOCATION AND NAMES OF WHOLESALE CUTS

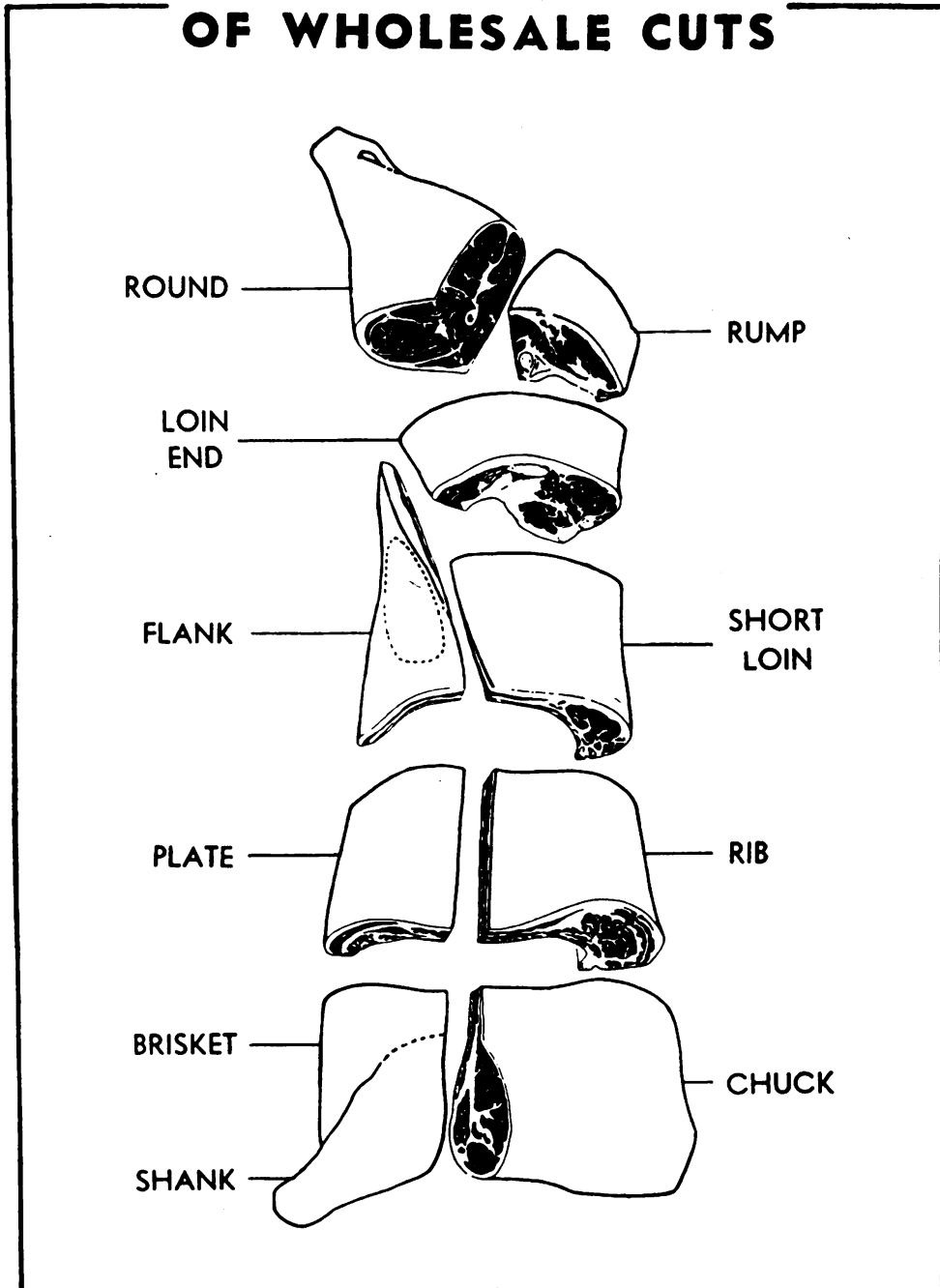

Prepared for the United States Army by the
NATIONAL LIVE STOCK AND MEAT BOARD

FIGURE 2.

BEEF CHART

LOCATION, STRUCTURE AND NAMES OF BONES

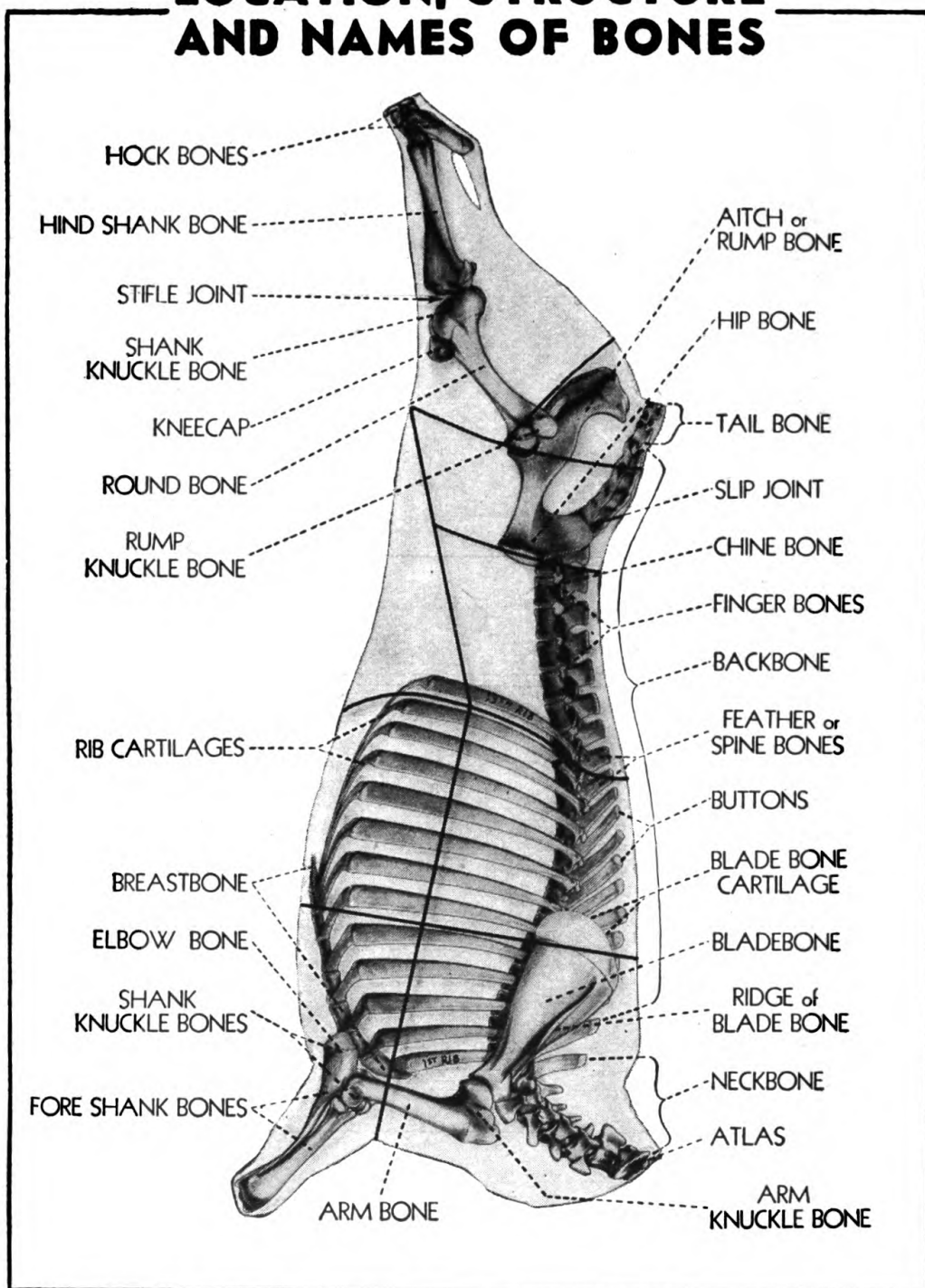

Prepared for the United States Army by the
NATIONAL LIVE STOCK AND MEAT BOARD

FIGURE 3.

usable meat from a side of beef. Incidentally, this method of cutting will produce the same kind of boneless cuts as the Army will be purchasing for its standard menus.

d. Cutting forequarter.—The forequarter is placed on the block with the meat side down. In this position the backbone, breastbone, and ribs are in plain sight, thus simplifying the job of cutting around them.

- (1) Pull the wooden or metal pin from the beef neck, if present.
- (2) Unjoint and remove the atlas joints. This is the first vertebra of the neck.
- (3) Trim the bloody meat from the throat side of the neck.
- (4) Remove loose heart fat which lies beside the breastbone, then remove the thin meat which covers the rib cartilages attached to the breastbone. Loosen brisket meat and fat from around the outside of the breastbone.
- (5) Cut a narrow strip from the thin edge of the skirt, or diaphragm muscle. Pull the thin papery membrane from the skirt and plate meat. With the knife lying nearly parallel with the ribs, cut under the skirt and over the rib cartilages, thus exposing all the cartilages attached to the rib bones. The meat which has just been loosened from the cartilages should be cut free from the plate meat. Beginning at the breastbone, loosen the plate meat from under the rib cartilages.
- (6) Remove the boneless strip of meat which lies along the chine bone of the chuck. Loosen the similar strip of meat from the throat side of the neck bone.
- (7) The feather bones, or spine bones, of the forequarter were scored with a saw in the packing plant. Break and remove the top or loose half of these bones, all along the back of the forequarter.
- (8) Loosen with a knife and pull the back strap (ligamentous strip) from the full length of the forequarter, starting at the rib end.
- (9) Cut back under the remaining sections of the feather bones to loosen these bones from the meat.
- (10) Unjoint neck bone where it joins the first rib vertebra. Cut around and under the neck bone so that it can be lifted from the meat in one piece.
- (11) Separate the rib and plate from the crosscut chuck, leaving seven ribs on the chuck (fig. 4, line *ab*). This can be done easily by sawing across the backbone and rib cartilage, between the seventh and eighth ribs. One full cut with a sharp steak knife will separate the two pieces of meat.

(12) Turn the rib and plate over, meat side up. Make a mark with the knife, one-half inch from the rib eye, at each end of the rib. Cut across the ribs joining these two knife marks to separate the plate meat from the rib meat (fig. 4, line *cd*). Do not saw the ribs.

(13) Starting at this knife mark, cut along parallel to the ribs and peel the plate meat in one piece from the bones, leaving the intercostal muscles, or rib fingers, attached to the ribs.

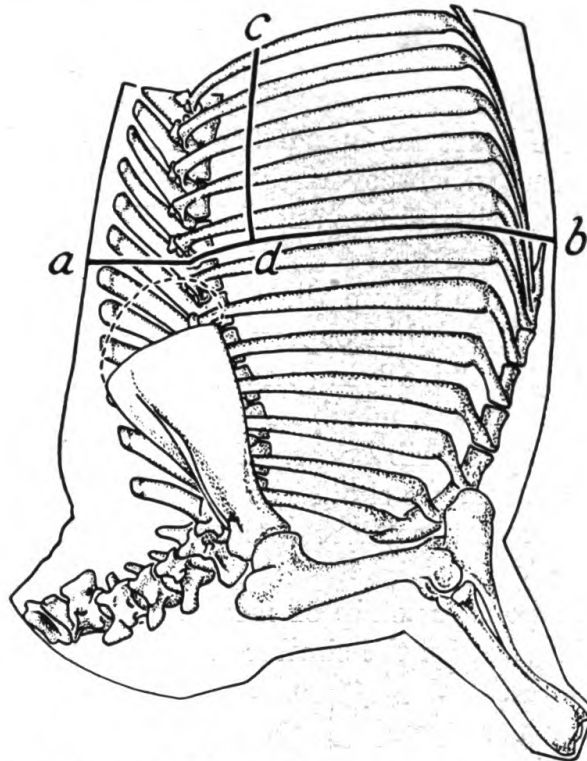

Line *ab* shows where plate and rib are separated from the crosscut chuck leaving seven ribs on the chuck.

Line *cd* shows where the plate meat is separated from the rib meat at the edge of the rib eye.

FIGURE 4.—Outside skeletal view of forequarter.

(14) Next, cut closely to the ribs and lift the spencer roll from its cradle of bones.

(15) Remove the rib fingers from between the ribs. This can be done by running the knife closely along each side of the ribs. Loosen the rib fingers from the plate side first, then turn the bones around and work from the backbone side. Each rib finger will come out in one piece.

(16) Turn the crosscut chuck over so that meat side will be uppermost. Study figure 5 to see how the shank and arm bones are to be unjointed from the blade bone.

(17) With the rib side of the chuck away from you, start at the end of the elbow bone *a* (fig. 5) and pull the knife toward you until it strikes the arm bone at *b*. Turn the knife and run it along the arm bone until it reaches the socket joint at *c*. At this point the knife goes through the socket joint to separate the arm bone from the shoulder blade.

(18) Remove the meat from in front of the shank bone, starting at point *d* (fig. 5). Cut to point *e* then run the knife over the top of the arm bone to *b*. Between points *e* and *b* and points *c* and *f* loosen all the meat from the arm bone so that the shank and arm bones can be lifted to one side. The meat attached to the shank bone should then be removed.

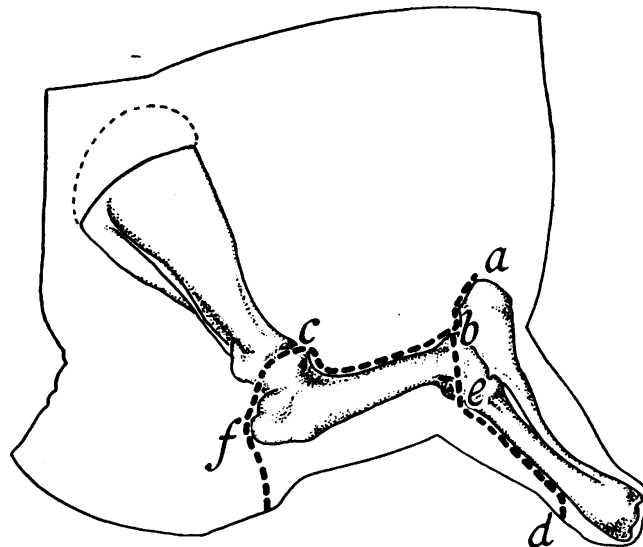

Dotted lines show path knife should follow in removing shank and arm bones.

FIGURE 5.—Outside view of blade, arm, and shank bones in a seven-rib crosscut chuck.

(19) Separate from the brisket the boneless meat that covered the front part of the shank and arm bones.

(20) The shoulder clod *a* (fig. 6) is removed by first running the knife along the side of the ridges of the bladebone. Next, cut the meat free from the narrow end of the bladebone. Start pulling the clod from the heavy end toward the back of the chuck, at the same time cutting underneath the clod meat at the natural seam which separates it from the brisket. Keep pulling and cutting until the thin part of the clod has been pulled from the bladebone.

(21) Remove the thin layer of meat which covers the chuck tender and neck muscles. This may be done by first running the tip of the knife along the top of the ridgebone to loosen the meat at that point.

Pull the layer of meat toward the end of the neck, cutting along the natural dividing seam as you pull.

(22) Lift out the chuck tender. See figure 6 for the location of this boneless piece of meat that resembles the tenderloin. First, run the knife along the ridgebone to loosen the meat from the bone. Next, cut underneath the tender at the dividing seam, pulling as you cut.

(23) Pull the boneless neck meat straight out in front of the chuck. Cut it off at a point 2 inches in front of the bladebone and parallel with the rib side of the chuck.

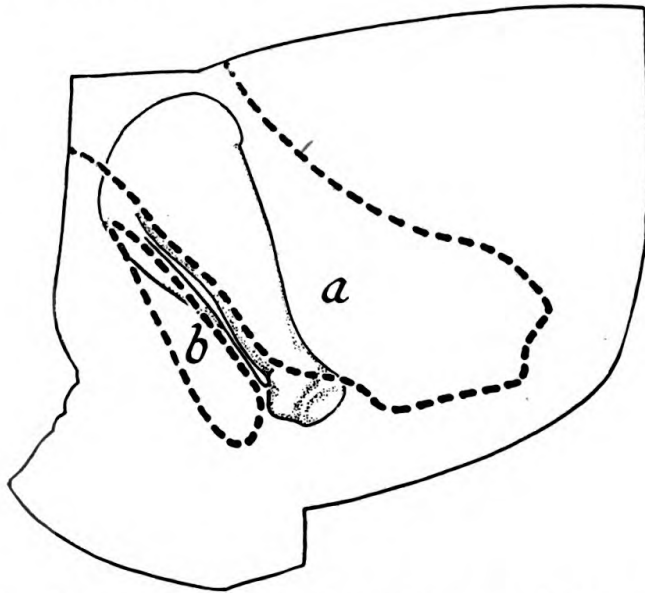

Dotted lines show location of shoulder clod *a* and chuck tender *b* with respect to blade bone.

FIGURE 6.—Outside view of the seven-rib crosscut chuck with arm and shank bones removed.

(24) The bladebone and cartilage attached to it can now be lifted from the inside chuck muscle. Cut close to the bone so that a minimum amount of meat will be left attached to the blade.

(25) Separate the thin brisket and rib meat from the thick back meat by cutting between them at the edge of the eye of the inside chuck muscle (fig. 7, line *ab*).

(26) Peel the brisket meat from the ribs by cutting closely to the bones, leaving the rib fingers attached to the ribs.

(27) Cut across the back muscle between the third and fourth ribs. The object here is to separate the tender inside chuck meat from the less tender neck meat.

(28) Cut closely along the ribs to remove the boneless chuck roll, from the fourth to the seventh ribs, inclusive.

(29) Separate the boneless neck roll from the ribs to which it is attached.

(30) Remove the rib fingers from between the first seven ribs of the forequarter as described in (15) above for the comparable five-rib plate section of the forequarter.

e. Cutting hindquarter.—The outside of the hindquarter should lie on the block. Most of the work of cutting and boning the beef hind will be done from the inside which is now uppermost.

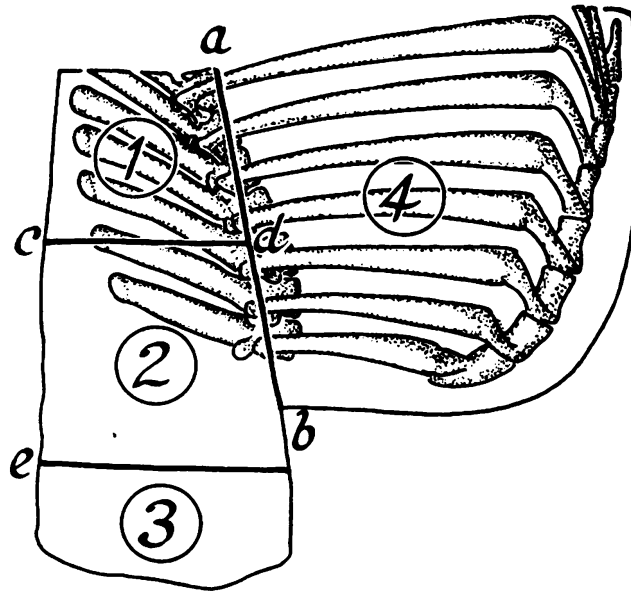

Line *ab* indicates division between thin brisket meat ④, and thick back meat ①, ②, and ③.
Line *cd* divides the four-rib chuck roll ① from neck roll ②.
Line *cb* shows where end of neck is separated from neck roll.

FIGURE 7.—Outside skeletal view of seven-rib crosscut chuck with neck, arm, blade, and shank bones removed.

(1) Remove the clod fat and flank in one piece. This is done by cutting under the fat and fairly close to the meat of the knuckle section of the round, then making a straight cut from the front edge of the knuckle to a point about 6 inches from the eye of the loin (figs. 3 and 8). It will be necessary to saw across the thirteenth rib.

(2) With the inside of the flank up, cut a thin strip from the naval side of the flank, then peel the membrane from the flank steak and flank meat.

(3) Beginning at the narrow end of the flank, cut and pull the flank steak back as far as it will come easily. Cut across the flank to separate the fat from the meat. Remove the bone (part of the thirteenth rib) from the flank meat.

(4) The clod fat should be cut into thin slices which later may be tied or laid on lean boneless roasts and pot roasts. This fat protects the lean meat while it is being cooked and adds to the flavor and juiciness of the cooked meat.

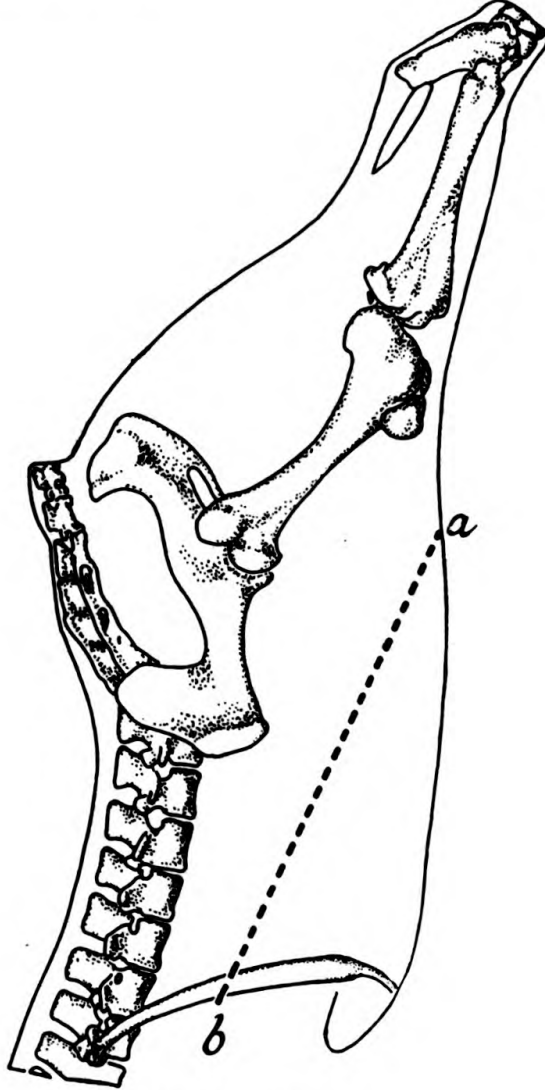

Dotted line *ab* shows where flank is removed.

FIGURE 8.—Outside view of bones in hindquarter of beef.

(5) The hanging tender is attached beneath the kidney knob of the left hindquarter. It should be removed and split open lengthwise, so that the gristle running through the center of it can be taken out.

(6) The kidney knob and all surplus fat should be removed from the inside of the loin and rump. The kidney knob can be cut open and the kidney removed.

(7) To separate the round from the loin and rump, saw through the tip of the aitchbone (fig. 9, dotted line *cd*), then cut down to the round bone, cutting as closely as possible to the aitchbone during the operation. Saw through the round bone and complete the separation by cutting with the knife.

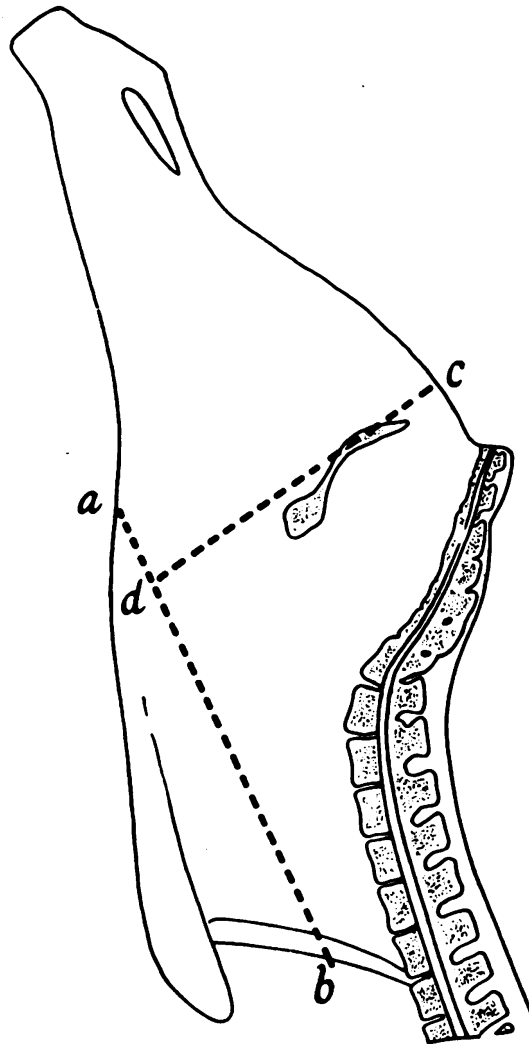

Dotted line *ab* shows where flank is removed.

Dotted line *cd* indicates where the round is separated from the rump and loin.

FIGURE 9.—Inside view of beef hindquarter showing exposed section of aitchbone, backbone, and thirteenth rib.

(8) The round is to be divided into four boneless cuts—the knuckle, inside, outside, and heel. This will be comparatively easy since, with the exception of the heel, the other cuts are separated by natural dividing seams. (See fig. 10 for location of the four cuts.) Figure 11 shows the dividing seams which separate the knuckle, inside, and outside.

(9) With the inside of the round up, use tip of knife to cut through the thin layer of meat from kneecap to face of the round above the round bone (fig. 10, dotted line *ab*). Pull thin layer of meat and membrane from the outside of the knuckle (fig. 11, dotted line *xy*). Cut meat loose from the knuckle at the block where it starts to go back under the round.

(10) Cut down the round bone from the kneecap to face of the round, following the same line made originally with the tip of the knife (fig. 10, dotted line *ab*, also fig. 11, line *xm*).

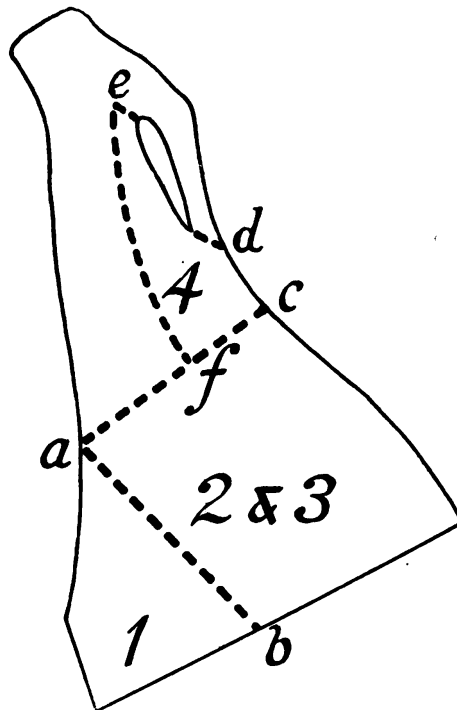

- 1. Knuckle.
- 2 and 3. Inside and outside round.
- 4. Heel.

FIGURE 10.—Outline of beef round showing location of the four major boneless cuts.

(11) Turn round over so that the outside will be uppermost. Use the tip of the knife to cut from the kneecap to the face of the round. Peel off the membrane from the outside of the knuckle (fig. 11, dotted line *yz*).

(12) With knife, follow the natural seam which separates the knuckle from the outside round. Cut down to the round bone from kneecap to face of round (fig. 11, line *zn*).

(13) Loosen the kneecap (figs. 3 and 10 at point *a*) and cut close to the bone under it. The knuckle meat can now be pulled from the round bone.

(14) Remove the shank by cutting through the stifle joint and across the meat of the lower round. (See stifle joint, fig. 3, also fig. 10, dotted line *afc*.) Stand the shank and the meat attached to it on end with the hock up. Cut through the opening under the hock bone to detach the tendon from the heel meat (fig. 10 at point *d*). Run the knife along the hind shank bone to remove the heel piece (fig. 10, dotted line *ef*). The remaining shank meat can now be trimmed from the shank bone.

(15) With the inside round up, trim off the surplus fat. Then cut under and remove the tough membrane which covers the fat-free section of the inside round (fig. 11, dotted line *xw*). Next, run the knife along the top side of the round bone, and cut through the dividing seam to separate the inside and outside pieces.

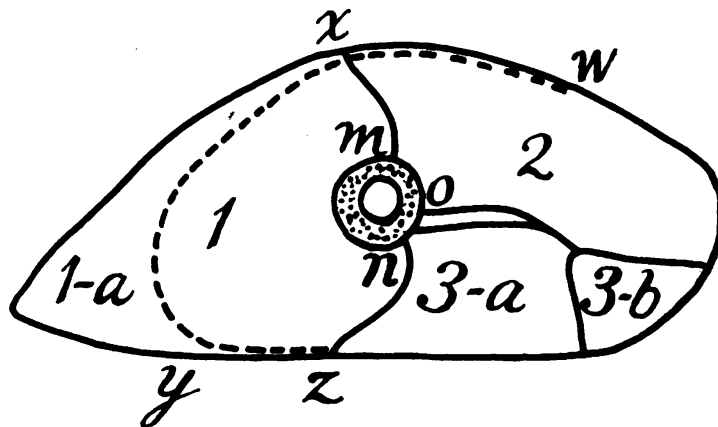

1. Knuckle.
 2. Inside.
 3-a to 3-b. Outside (3-a is bottom round and 3-b is the eye; these muscles together form the outside).
 Dotted line *xyz* separates membrane, fat, and tip end of flank 1-a from knuckle 1.
 Dotted line *xw* indicates location of tough membrane covering fat-free section of inside round.

FIGURE 11.—Sketch of face of beef round showing natural divisions of the three major cuts.

(16) Cut along the round bone to separate it from the outside round.

(17) The rump is separated from the loin by sawing through the bone about 1½ inches in front of the tip of the aitchbone and across the backbone about 4 inches in front of the first tail bone (fig. 12, dotted line *ab*). Finish the separation by cutting with the knife.

(18) To facilitate boning the rump, saw down through the aitchbone about 1 inch back of the tip so that the rump knuckle bone can be cut loose in one piece (fig. 12, saw at point *c*). Cut the meat from this bone. Now remove the tail bone, then the aitchbone. Trim

loose meat from the boneless rump so that the resulting rump butt will be a smooth, blocky piece of meat.

(19) The trimmed loin is on the block, meat side down. The tenderloin should be removed first (fig. 12, point 1). To do this run the knife close along the chine bone, then starting at either the rump or rib end (whichever is most convenient, depending upon whether the loin is from the right or left side) strip the tenderloin, with the aid of the knife, from the inside of the loin. Cut close to the

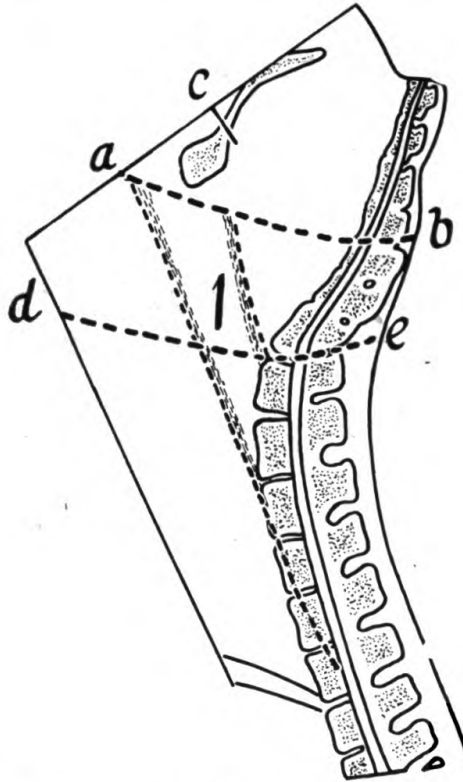

Dotted line *ab* shows where rump is separated from loin.

Point *c* indicates place to saw across aitchbone of rump in order to remove knuckle bone.

Point *1* shows location of tenderloin. The loin end is separated from the short loin at dotted line *de*.

FIGURE 12.—Inside view of loin with rump attached.

finger bones and hip bone, leaving no more meat than is necessary on these bones.

(20) The loin end can now be separated from the short loin. Cut through the meat from the top side of the loin immediately in front of the hip bone. Saw through the backbone to finish dividing these two wholesale cuts (fig. 12, dotted line *de*). With practice this separation can be made without a saw by making a cut with the knife between the sacral and lumbar vertebrae, then breaking the backbone over the edge of the block.

(21) The hip bone and backbone may be removed from the loin end in one piece. The first step is to cut along the feather or spine bones on the top side. Turn the piece over and cut closely around the hip bone, then the backbone. Continue cutting until all the meat has been loosened from these bones. Trim off loose pieces of meat so that the boneless sirloin butt will be a smooth, neat-looking cut of meat when you are through with it.

(22) The easiest way to remove the bones from the shell loin (short loin with tenderloin out) is to separate the meat from the feather or spine bones first. One continuous cut with a sharp knife is all that will be necessary. Cut close to the feather bones the full length of the loin. Now turn the shell loin on edge so that it rests on the backbone. With the aid of the knife, separate the loin meat from the finger bones. The meat which remains attached to the backbone is the most difficult to remove. This is where a good sharp boning knife comes in handy. By carefully weaving the tip of the knife around the processes of the vertebrae, most of the meat can be detached from the bone and left on the loin strip. Cut the flank meat from the loin strip on a line with the edge of the eye muscle.

f. Beef cuts and their uses.—The wide variety of boneless cuts from the side of beef may be used in a number of different ways. Generally speaking, however, the most satisfactory results in cooking will be obtained by using the tender cuts for roasts and steaks and the less tender cuts for such dishes as pot roasts and stews, and in ground form for meat loaf, patties, and chili. When buying forequarters and hindquarters alternately it is often a good idea to save the spencer roll (and chuck roll, if needed) from the forequarter, to cook with the tender cuts from the hindquarter. The heel and outside round from the hindquarter can be held back to cook with the less tender forequarter cuts. The following table shows the use recommended for the various boneless beef cuts:

BEEF FOREQUARTER

Name of cut	Recommended use
<i>Tender cuts</i>	
Spencer roll.....	Roast, steaks.
Chuck roll.....	Do.
<i>Less tender cuts</i>	
Shoulder clod.....	Pot roast, stew.
Chuck tender.....	Do.
Neck roll.....	Do.
Boneless plate.....	Pot roast (when rolled), stew.
Boneless brisket.....	Do.
Boneless meat (skirt, shank, arm, neck, rib fingers).....	Stew, ground beef.

BEEF HINDQUARTER

Name of cut	Recommended use
<i>Tender cuts</i>	
Knuckle.....	Roast, steaks.
Inside round.....	Do.
Rump butt.....	Do.
Tenderloin.....	Do.
Sirloin butt.....	Do.
Loin strip.....	Do.
<i>Less tender cuts</i>	
Outside round.....	Pot roast, stew.
Heel.....	Do.
Boneless flank.....	Stew, ground beef.
Kidney.....	Stew, gravy.
Boneless meat (hanging tender, shank, trimmings from rump, sirloin butt, and loin strip).	Stew, ground beef.

g. Beef cutting test.—No two sides of beef are exactly alike, and no two men cut meat exactly the same way. As a result the figures given here will not be identical to the yields you may expect in your kitchen; but the following table will give a close approximation of the number of pounds of meat you may expect from forequarters and hindquarters of beef weighing from 125 to 180 pounds each.

BEEF HINDQUARTER

Name of cut	125-pound hindquarter	150-pound hindquarter	180-pound hindquarter
	<i>Pounds</i>	<i>Pounds</i>	<i>Pounds</i>
Inside round.....	14.5	17.4	20.9
Outside round.....	13.0	15.6	18.7
Knuckle.....	7.5	9.0	10.8
Heel of round.....	4.5	5.4	6.5
Rump butt.....	4.0	4.8	5.8
Sirloin butt.....	9.5	11.4	13.7
Loin strip.....	7.5	9.0	10.8
Tenderloin.....	5.5	6.6	7.9
Boneless meat.....	20.5	24.6	29.5
Kidney.....	1.5	1.8	2.1
Bones.....	21.0	25.2	30.3
Fat and waste.....	16.0	19.2	23.0
Total.....	125.0	150.0	180.0

BEEF FOREQUARTER

Name of cut	125-pound forequarter	150-pound forequarter	180-pound forequarter
	<i>Pounds</i>	<i>Pounds</i>	<i>Pounds</i>
Shoulder clod.....	11.7	14.0	16.8
Chuck tender.....	1.8	2.3	2.8
Spencer roll (5 ribs).....	7.7	9.3	11.2
Chuck roll (4 ribs).....	5.6	6.8	8.2
Neck roll.....	7.0	8.4	10.0
Brisket roll.....	10.5	12.6	15.2
Plate roll.....	6.0	7.3	8.8
Boneless meat.....	41.0	49.0	58.6
Bones.....	25.5	30.5	36.6
Fat and waste.....	8.2	9.8	11.8
Total.....	125.0	150.0	180.0

h. Beef cuts divided according to cooking methods.—Following is a summary of all the boneless cuts in a side of beef grouped according to their tenderness and the most acceptable method of cooking.

ROASTS AND STEAKS (tender cuts)

Name of cut	125-pound hindquarter, 125-pound forequarter	150-pound hindquarter, 150-pound forequarter	180-pound hindquarter, 180-pound forequarter
	<i>Pounds</i>	<i>Pounds</i>	<i>Pounds</i>
Inside round.....	14.5	17.4	20.9
Knuckle.....	7.5	9.0	10.8
Rump butt.....	4.0	4.8	5.8
Sirloin butt.....	9.5	11.4	13.7
Loin strip.....	7.5	9.0	10.8
Tenderloin.....	5.5	6.6	7.9
Spencer roll (5 ribs).....	7.7	9.3	11.2
Chuck roll (4 ribs).....	5.6	6.8	8.2
Total.....	61.8	74.3	89.3

POT ROASTS (less tender cuts)

Outside round.....	13.0	15.6	18.7
Heel of round.....	4.5	5.4	6.5
Shoulder clod.....	11.7	14.0	16.8
Chuck tender.....	1.8	2.3	2.8
Neck roll.....	7.0	8.4	10.0
Brisket roll.....	10.5	12.6	15.2
Plate roll.....	6.0	7.3	8.8
Total.....	54.5	65.6	78.8

BEEF STEW (less tender boneless meat)

Flank, neck.....	41.5	49.7	59.5
Rib fingers, kidney, and trimmings from plate and brisket.....			

BEEF FOR GRINDING (less tender boneless meat)

Shank, hanging, tender, and trimmings too small for stew.....	21.5	25.7	30.7
---	------	------	------

MISCELLANEOUS

Name of cut	125-pound hindquarter, 125-pound forequarter	150-pound hindquarter, 150-pound forequarter	180-pound hindquarter, 180-pound forequarter
Bones.....	Pounds 46. 5	Pounds 55. 7	Pounds 66. 9
Fat and waste.....	24. 2	29. 0	34. 8
Total.....	70. 7	84. 7	101. 7

SUMMARY OF PRECEDING FIGURES

	Pounds	Pounds	Pounds
Roast and steaks.....	61. 8	74. 3	89. 3
Pot roasts.....	54. 5	65. 6	78. 8
Beef stew.....	41. 5	49. 7	59. 5
Ground beef.....	21. 5	25. 7	30. 7
Bones, fat and waste.....	70. 7	84. 7	101. 7
Total.....	250. 0	300. 0	360. 0

i. Army boneless beef.—(1) This is carcass beef of Army specification, class, grade, and weight, cut into wholesale market cuts in accordance with specific instructions. The bones, excess fat, gristle, and tendons are removed and the cuts of boneless beef separated into groups according to their tenderness. The most tender cuts are packed for use as roasts and steaks, while the less tender cuts are packed for use as boiling or stewing beef, or for ground meat (hamburger, meat loaf, etc.). The larger cuts are individually wrapped in waxed paper and the smaller cuts wrapped in units of about 10 pounds. The wrapped meat is packed in fiberboard boxes coated on the inside with paraffin. The meat may be chilled but is usually frozen.

(2) Army boneless beef has many advantages over carcass beef. All the meat delivered is edible and there is no waste in bones, fat, or gristle. It requires no butchering except the further cutting for steaks and stews. It reduces required storage space by 60 to 70 percent. It reduces weight by approximately 25 percent. It supplies meat in cuts more suitable for definite purposes than would be possible from the use of carcass beef.

(3) Frozen Army boneless beef should be thawed in the original container, either in chill rooms or at room temperature. Seventy-

two hours or more may be required to defrost frozen boneless beef in chill rooms, but at room temperatures the meat becomes sufficiently defrosted for use in 24 hours. Frozen meat should not be defrosted in water, either hot or cold. No deterioration will take place during defrosting if the meat is kept wrapped and in the shipping boxes. Beef does not have to be completely defrosted before it is used. However, meat containing considerable frost requires a somewhat longer time to cook. For the thawing of frozen meat in the field see paragraph 31*g*.

(4) Army boneless beef should not be confused with commercial boneless beef which is made from lower grades of beef, largely from cow and bull carcasses. Such boneless cuts are deficient in tenderness palatability and food value, and should never be accepted for Army boneless beef.

21. Wholesale market cuts of beef for small messes.—In small messes where it is impractical to use beef in quarters, wholesale market beef cuts are available. These should be of the same class and grade required for carcass beef. Beef purchased as wholesale market cuts usually costs the organization more than when quarters are purchased. However, certain cuts can be readily obtained that will meet all the requirements of the mess at no increased cost. The square-cut chuck weighs just a little more than half the weight of the forequarter. The round weighs just a little less than half the weight of the hindquarter. The square-cut chuck sells at an average of 15 to 20 percent less than carcasses, and the round sells at an average of 15 to 20 percent more than carcass price. These two cuts when bought alternately will cost just about the same as carcass beef, and will yield beef suitable for every purpose for which the whole carcass could be used. They have the advantage over carcass beef in having less waste because carcasses contain the skirt, flank, kidney knob, etc., which have waste and are not easy to use to advantage. Wholesale market cuts should be used in the same way as described for those cuts under carcass beef.

22. Lamb.—*a. General.*—According to available figures approximately 93 percent of the lambs produced in this country are marketed before they are old enough to be called mutton. Climatic conditions in different parts of the country, combined with orderly marketing on the part of lamb growers and feeders, are responsible for making quality lamb available the year around.

b. Four classifications.—The four general classifications of lamb are: hothouse lamb, genuine spring lamb, spring lamb, and lamb. Hothouse lambs are in the luxury class. Their sale is limited to a

few of the largest cities. Genuine spring lambs are from about 3 to 5 months old. Since practically all lambs are born from December to June inclusive, depending upon the climate in various sections of the country, this means that genuine spring lamb is available from March to November, although it is most plentiful from April to July. Spring lambs are from about 5 to 8 months old. The bulk of these lambs reach the market from July to December. The fourth classification, "lamb," refers to those which are from approximately 8 to 12 months of age. Most of these lambs come from the feed lots and are usually available from January to May.

c. How to identify.—(1) There is no definite age when lamb becomes mutton but there are certain features which characterize young lamb, lamb, and mutton. Bones are the most important indication of age. The bones in young lamb are soft and reddish in color. As the animal becomes older the bones gradually harden, and at the same time they lose their pinkish color and turn white. The "break" joint in the lower fore shank bone is a sure means of identifying lamb. This joint has four well-defined ridges. In young lamb the ridges are smooth, moist, and red. As the lamb matures this joint loses its color and moistness. When the mutton stage is reached the break joint cannot be broken. The forefoot must be taken off at the round (spool) joint, immediately below the break joint.

(2) Lamb cannot be identified by its size. Excellent quality fed lambs often weigh more than mutton. Improved breeding and feeding are producing top quality dressed lambs which weigh as high as 60 pounds or more. A good indication of age, however, is the color of flesh. In lamb the color varies from light to dark pink. The color deepens as the animal grows older. In mutton the flesh will be dark red. Lamb fat is softer than mutton fat. It is creamy white or slightly pink. Mutton fat is whiter and more brittle.

d. Place of lamb in mess.—Lamb has a definite place in the Army menu. It is easy to cut, cook, and serve. The meat is young and tender. Its appearance on the table will be welcomed by the men because of the variety it adds to the menu. The entire back section (shoulders, rack, loin, and legs) can be cut into chops for broiling and pan-broiling; but probably the most satisfactory method of using carcass lamb in the Army menu is to serve it in two ways—lamb stew and lamb roast. When used as stew, all surplus fat should be removed from the meat. Roast lamb should be cooked well done or just slightly under the well-done stage. The "fell," that thin, papery covering over the lamb, does not need to be removed from lamb roasts. It does not affect the flavor of the lamb and, when left on, it helps

to keep in the juices and hold the roasts in shape. The fell should be removed from loin and rib chops.

23. Lamb cutting.—*a. General.*—The bone structure in the lamb carcass is almost identical with that of beef. Wholesale market cuts of lamb differ from beef, however, in form, size, and names. Since lamb is light in weight it is seldom split into sides but is sold either whole, or divided into from two to four wholesale market cuts. These cuts may be as follows:

- (1) Saddle----- legs and loin (unsplit).
Rack----- forequarters (unsplit).
- (2) Long saddle----- legs, loin, and hotel rack (unsplit).
Triangle or stew_ shoulders, breasts, shanks, and neck (unsplit).
Legs----- two legs unsplit.
- (3) Loin----- unsplit.
Hotel rack----- unsplit.
Triangle or stew_ shoulders, breasts, shanks, and neck (unsplit).

The lamb chart (fig. 13) shows the carcass of lamb broken into cuts. Normally the shoulders, breasts, shanks, and neck are not separated as shown in the chart but are sold in one piece as a triangle, stew, or slug. The usual packinghouse procedure is to leave the first three ribs in the shoulders and nine ribs in the hotel rack. One rib (the thirteenth) is left in the saddle. Figure 14 shows the structure and names of the bones. The solid lines show one method of dividing the lamb into wholesale cuts.

b. Army method of cutting lamb.—In order that carcass lamb may be used to the best advantage in the Army menu, a special method of cutting was developed. This method utilizes the whole lamb as two major cuts, the long saddle and the triangle. The long saddle, which includes the legs, loin, and hotel rack, is used for boneless roasts. The triangle, consisting of the shoulders, breasts, shanks, and neck, is used for boneless stew. This method of cutting yields about the right proportion of stew and roasts. One hundred pounds of carcass lamb will provide approximately 24 pounds of boneless stew and 35 pounds of boneless roast. If more roast lamb and less stew is desired, either one or both shoulders can be rolled for roasting. When one shoulder is roasted with the cuts from the long saddle, 100 pounds of lamb will provide approximately 44 pounds of boneless roasts, leaving 15 pounds of boneless lamb for stew. Of course, the entire

lamb could be used for either of these dishes, but the division just described gives variety in the menu and is the most economical method of using the carcass.

c. Cutting lamb triangle.—These instructions will start with the full carcass since it is assumed that most lamb for the Army will be purchased in carcass form. It is recommended that the triangles be cut up for stew first, leaving the long saddles for a later meal. The fat covering inside and outside the long saddles gives them the necessary protection for a few days of aging.

(1) Put the lamb on the block with the back up.

(2) Use the knife and saw to remove the neck at the point where it joins the shoulder.

(3) Pull the fell and excess fat from the outside of the neck. Remove the neck bone in one piece. Pull out the backstrap, then cut the boneless meat into suitable pieces for stew.

(4) Turn the carcass on its side, breasts nearest the cutter.

(5) Start at the cod fat and cut through the uppermost flank to about the middle of the thirteenth rib. Continue cutting over the ribs to a point about 1 inch above the elbow joint, then cut straight across the arm bone. Saw across the arm bone; then hold the flank firmly in the left hand and saw across the ribs, following the cut made with the knife.

(6) Remove the shank and breast from the other side of the lamb. This can be done by dropping the saw blade on the first rib of the lower breast (the position of the lamb is not changed) and sawing parallel to the cut made in removing the upper breast. Saw through ribs, arm bone, and meat from the first to the thirteenth rib, then finish with a knife by cutting through the flank to the cod fat.

(7) Separate the shanks from the breasts. Pull the fell from the shanks. Remove the meat from the bones and cut it into stewing pieces.

(8) Take one breast at a time, with rib side up, and cut under the diaphragm muscle to expose the rib cartilages. Then slide the knife underneath the rib bones and lift them out by guiding the knife closely along the bones. Turn the breast over and pull off the fell. Trim off all surplus fat. Cut boneless meat into pieces for stew.

(9) Turn the remaining section of the lamb on its back. Cut and saw between the fifth and sixth ribs on each side of the carcass to separate the square-cut shoulders from the long saddle.

(10) Separate the two shoulders from the ribs and the unsplit backbone. Start with the arm sections of the shoulders up. Loosen

LAMB CHART

LOCATION AND NAMES OF WHOLESALE CUTS

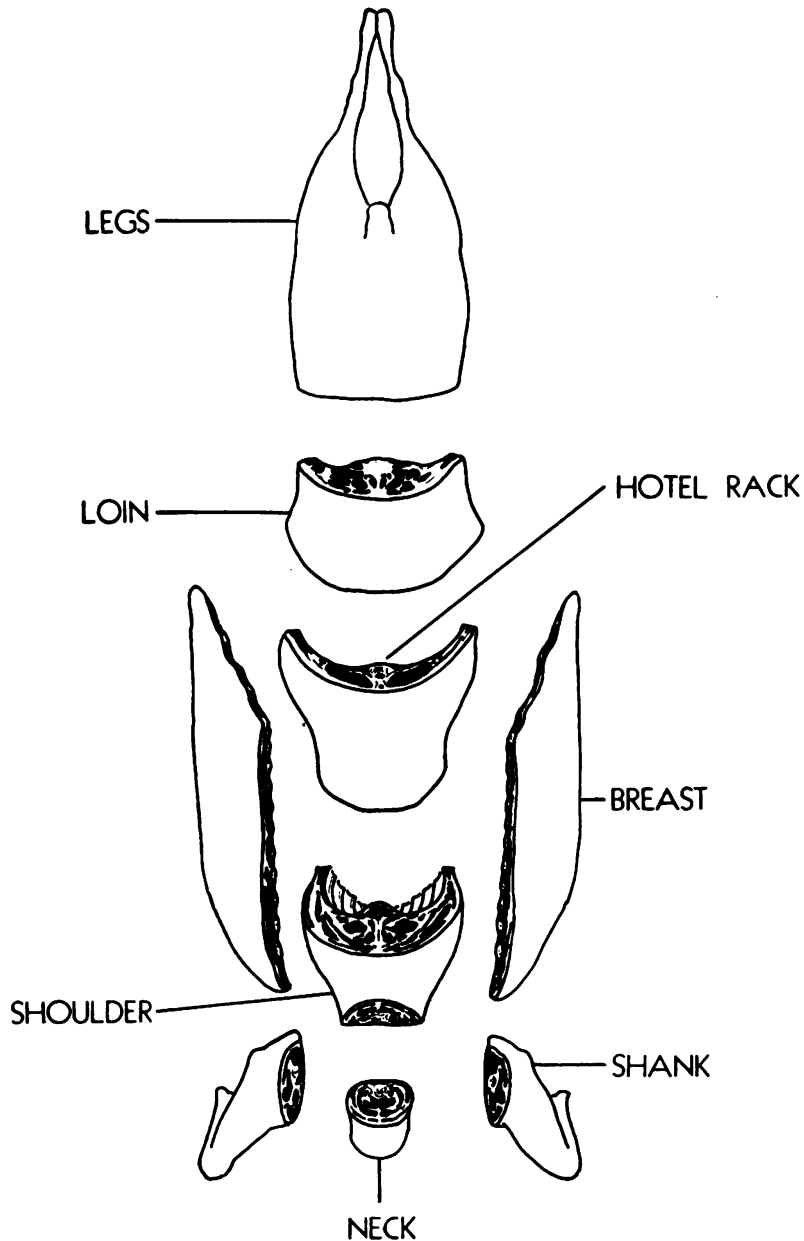

Prepared for the United States Army by the
NATIONAL LIVE STOCK AND MEAT BOARD

FIGURE 13.

LAMB CHART

LOCATION, STRUCTURE AND NAMES OF BONES

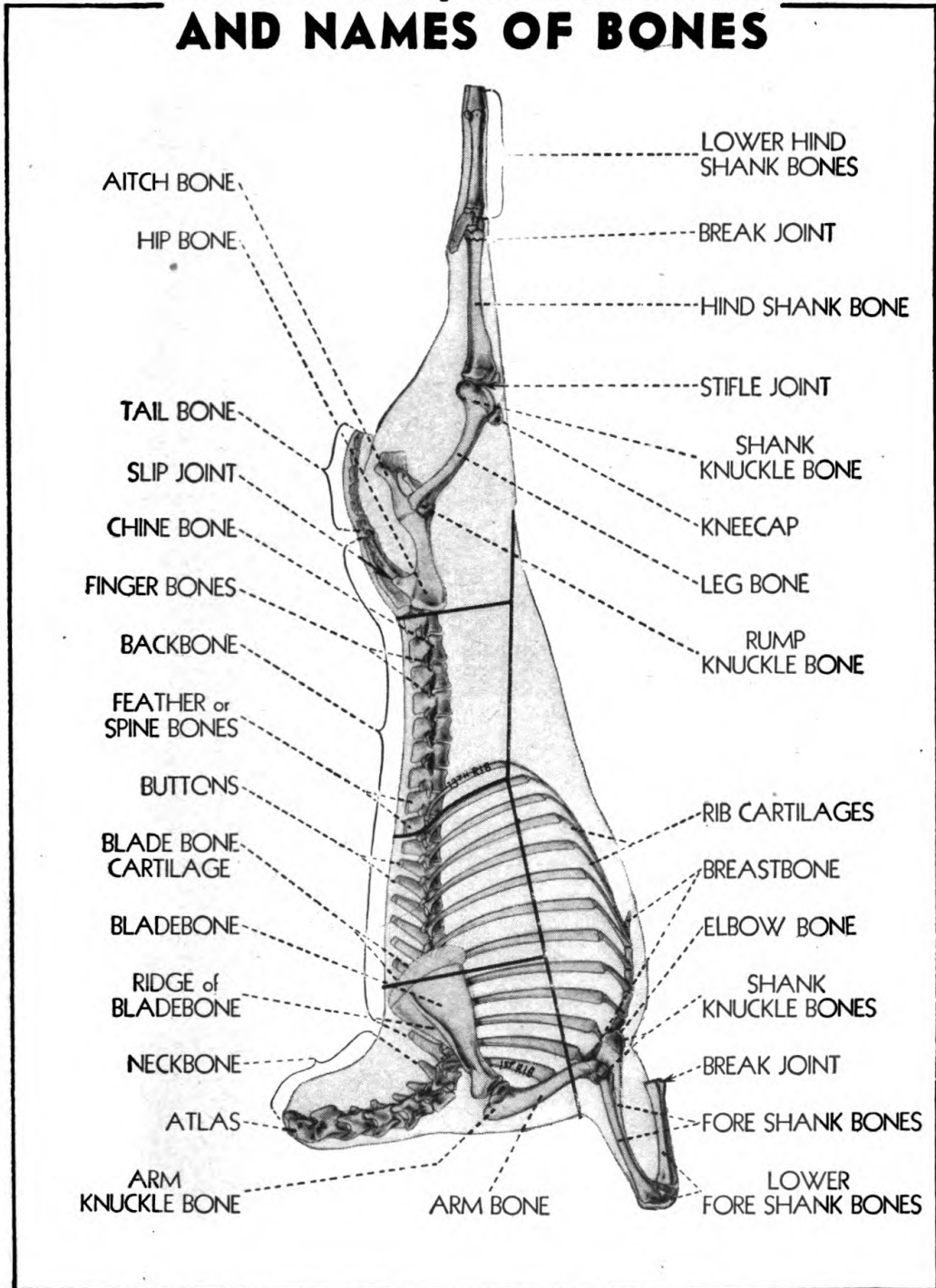

Prepared for the United States Army by the
NATIONAL LIVE STOCK AND MEAT BOARD

FIGURE 14.

the meat by cutting down toward the block alongside the rib bones, then along the spine or feather bones, first on one shoulder, then the other. Turn the shoulders over so that the arm sections are down. Cut around the backbone from the top side to finish removing the shoulder ribs and backbone.

(11) Pull the backstrap from the back sides of both shoulders.

(12) Work on one shoulder at a time. Place the shoulder on the block, outside down. Open the shoulder from the rib and arm sides. Cut back into the meat, parallel with the block, until the arm bones and bladebones are exposed. With the tip of the knife cut along the edges of these two bones. Unjoint and remove the arm bone. Scrape the front end of the ridgebone, then pull out the shoulder blade.

(13) When the shoulder is to be used for stew, remove surplus fat while cutting the meat into small pieces.

(14) If one or both shoulders are to be roasted, roll and tie, using the rib side as the face of the roll.

d. Cutting long saddle.—The shoulders and the long saddle are the most desirable sections of the lamb for roasts. The roasts from the long saddle are the boneless rack, boneless loin, and boneless legs.

(1) Separate the hotel rack from the loin by cutting across both flanks to the backbone, immediately back of the thirteenth rib. Complete the separation by sawing across the backbone. There will be eight ribs in the hotel rack, since five ribs were left in the shoulders.

(2) Place the rack on the block, meat side down and ribs pointing up. Run the knife down, close to the ribs and feather bones, on both sides of the rack. This will loosen the meat from the bones on the end of the rack nearest the cutter. Turn the rack, end for end, and repeat the boning process. The meat should now be entirely free from the bones, and in two pieces.

(3) Remove the bladebone cartilages from the shoulder ends of the two pieces of rack meat. Pull the backstraps from the meat and remove surplus fat.

(4) In order to make the boneless roll uniform in thickness, reverse the ends of the two pieces of meat. Lay one piece of meat on the block, fat side down. Lay the cut surface of the second piece on the cut surface of the first piece in such a manner that the eye muscles will touch each other. Roll and tie with three or four cords.

(5) Separate the loin from the legs by cutting just in front of the hip bones.

(6) With fell side resting on the block, cut all kidney fat from the inside of the loin.

(7) Lift the kidneys from the kidney fat.

(8) With the tip of the knife loosen the tenderloins on each side of the backbone. Slide the knife along the finger bones to roll the tenderloins back over the flanks.

(9) Cut back under the finger bones, then down along the feather or spine bones on each side of the backbone. When lifting out the backbone be careful not to cut through the thin meat that connects the two pieces of boneless loin.

(10) Fold the loin together and tie with three or four cords.

(11) Split the two legs. With the outside of legs up, saw lengthwise down through the center of the backbone and tail bone.

(12) Bone one leg at a time. First, place leg on block with inside of leg up. Cut away all surplus fat around the aitchbone and flank side of leg.

(13) Cut through the stifle joint to separate the shank meat and shank bones from the leg.

(14) Pull the fell from the shank meat. Trim the meat from the shank bone. The shank meat will be used later ((18) below).

(15) Remove the pelvic bone (aitchbone and hip) and the backbone and tail bone. These bones can be taken out in one piece, although the job is made somewhat easier when they are separated at the slip joint (fig. 14). The first step is to loosen and roll back the tenderloin so the hip section of the pelvic bone will be exposed.

(16) Unjoint the pelvic bone from the leg bone. Continue to cut closely around the pelvic bone to separate it from the meat. Keep cutting until the pelvic bone, backbone, and tail bone have been removed from the leg.

(17) Split the inside of the leg open lengthwise to expose the leg bone. Cut meat from around the leg bone so that it may be lifted out. Also remove the kneecap from the shank end of the leg.

(18) Use shank meat to fill opening in leg where pelvic bone was removed.

(19) Roll the boneless leg lengthwise and tie it into shape.

24. Fresh pork.—*a. General.*—Pork is seldom sold in carcass form or in sides. Practically all hog carcasses are made into commercial cuts in the packing plant (see pork chart, fig. 15). The heavy lines on the bone structure chart (fig. 16) show the division of the side into the major wholesale cuts. About 30 percent of the pork carcass is sold fresh; the rest is made into cured and smoked meats, rendered into lard, or manufactured into sausage. Demands of the trade influence the way the side of pork will be cut and used. Consequently, pork cuts cannot be classified definitely as those which are always sold fresh and those which are always cured, be-

PORK CHART

LOCATION AND NAMES OF WHOLESALE CUTS

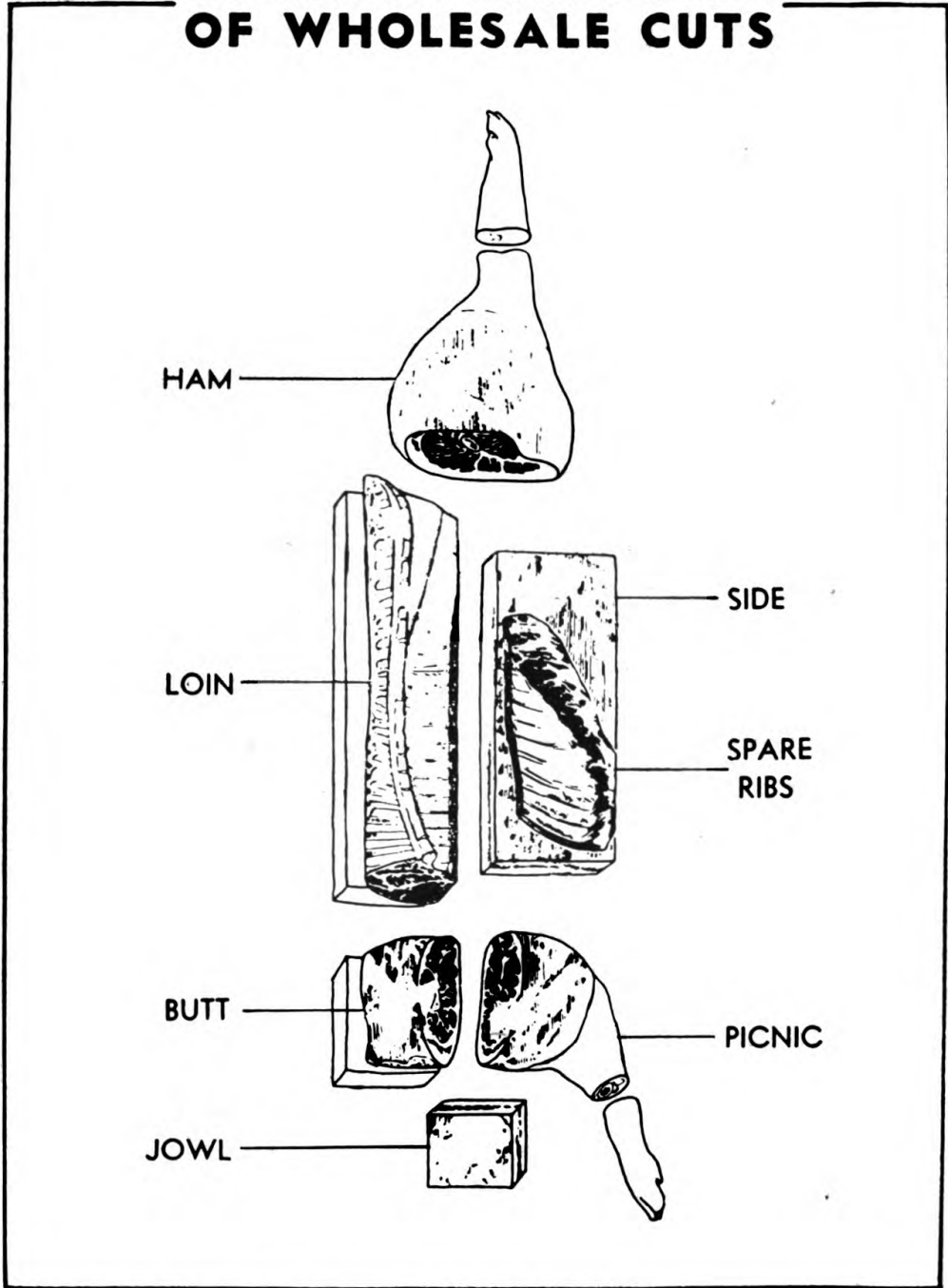

Prepared for the United States Army by the
NATIONAL LIVE STOCK AND MEAT BOARD

FIGURE 15.

PORK CHART

LOCATION, STRUCTURE AND NAMES OF BONES

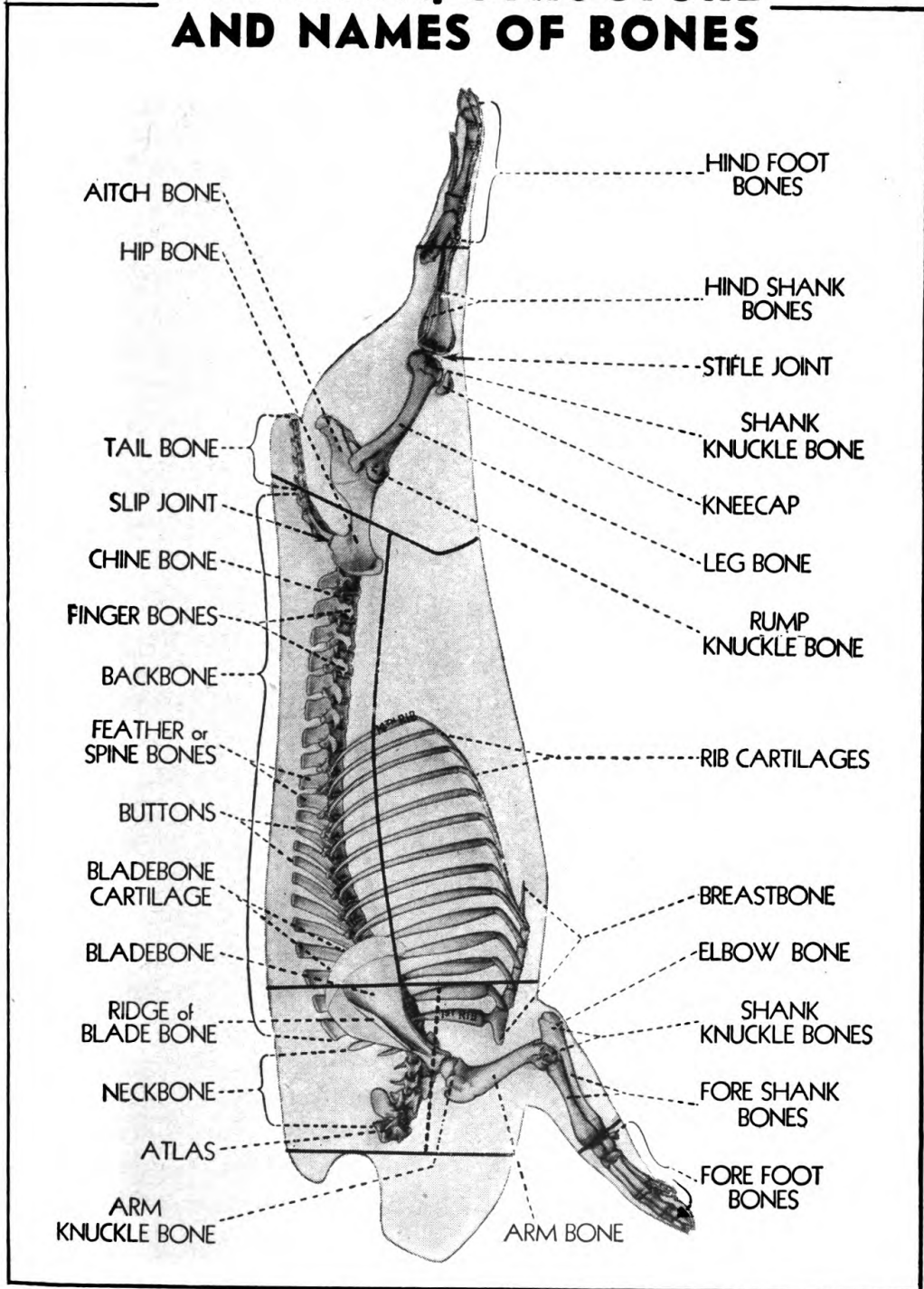

Prepared for the United States Army by the
NATIONAL LIVE STOCK AND MEAT BOARD

FIGURE 16.

cause practically every pork cut may be cured, and under certain conditions, is cured. On the other hand, some of the cuts which are usually cured may be available as fresh pork.

b. Pointers about pork.—Most hogs are marketed under 1 year of age, so the flesh is usually tender and the bones soft. In older hogs, however, the meat will not be as tender and the bones will not be as soft as they are in young pork. In general, the pork produced in the United States is quite uniform, so there are fewer grades than in other meats. The color of young pork is a grayish pink changing to a delicate rose in the older animal. The flesh is comparatively firm and fine grained, and free from excessive moisture. The lean is well marbled and covered with a firm white fat.

c. Place of pork in Army mess.—(1) There are several reasons why pork is valuable in the Army mess. It has a high fat content which makes it an excellent energy food. A meal containing considerable fat “sticks to the ribs.” That is one reason why nothing is so satisfying as a breakfast of ham or bacon and eggs. Pork is an outstanding source of thiamine (vitamin B₁). This vitamin is needed for growth; it aids in the utilization of carbohydrates; it promotes the health of the body cells; and it prevents the disease, beriberi. Pork is a universally liked meat. The per capita consumption of pork and beef in the United States has been approximately the same for many years. Pork is also valuable in the Army mess from the standpoints of variety and economy. Sometimes the statement is made that pork is “hard to digest,” but this is not true. Being somewhat fatter than other meats it may remain in the stomach for a longer period; but it digests in the same length of time as chicken, and in common with other meats, it is completely utilized by the body.

(2) Pork should *always* be cooked thoroughly for the following reasons:

(*a*) Pork muscle (lean meat) may contain trichinae. These microscopic parasites cause trichinosis in human beings. Fortunately the trichina parasite is killed by thorough cooking. Well-done pork is perfectly safe to eat.

(*b*) The rich, delicious flavor of pork is developed more fully when it is cooked slowly and thoroughly.

25. Preparing fresh pork.—*a. General.*—The preparation of pork for the mess does not require much work because the cuts are of a size and form that are easily handled. The usual fresh cuts are shoulders, fresh picnics, Boston style butts, loins, spareribs, neck bones, and at some seasons of the year fresh hams or leg of pork.

b. One roast from light shoulder.—When the pork shoulder weighs less than 12 pounds it can be made into a single boneless roll that will be the right size and thickness for roasting.

(1) Remove the shoulder hock, with knife and saw, from immediately above the elbow joint.

(2) Take the collar, or skin, from the outside of the arm section of the shoulder.

(3) Turn the meat over so that the fat side rests on the block.

(4) Split open the shoulder from the arm and blade sides. Cut into the meat, parallel with the block, until the arm bones and blade-bones are exposed.

(5) Unjoint and remove the arm bone.

(6) Cut meat free from underneath the blade so that this bone may be lifted out.

(7) Fold the boneless meat into a long roll and tie securely.

c. Two roasts from heavy shoulder.—A single boneless roast from a shoulder weighing much more than 12 pounds is apt to be quite thick. While it can be roasted, a better plan is to split the heavy shoulder into two boneless roasts, as follows:

(1) Cut off the hock, close above the elbow bone.

(2) Remove the collar, or skin, from the outside of the arm section.

(3) The fat side should be resting on the block. Split the shoulder open parallel with the block; begin at the shank end and follow the natural seam that separates the inside and outside shoulder muscles.

(4) Lift off the boneless inside muscle. Roll and tie.

(5) Open the remaining section of the shoulder from the blade and arm sides. Cut through the meat until the arm bones and blade-bones are exposed. Remove these bones by cutting the meat loose from them.

(6) Roll the boneless outside muscle into a long, narrow roast. Tie with a few cords to hold it in shape during cooking.

d. Pork steaks from shoulder.—When pork shoulders are selling for several cents a pound less than loin, it is an advantage to serve shoulder pork and steak occasionally.

(1) Remove the hock and collar as described in *b* and *c* above.

(2) With the knife and saw, cut steaks about one-fourth inch thick from the arm section of the shoulder. Fat side of shoulder should be up. Start at the shank end and continue cutting until the blade-bone is reached.

(3) Turn the remaining section of the shoulder (Boston style butt) so that blade steaks can be cut at right angles to the arm

steaks that were just removed. Start at the end where the bladebone is exposed. Use knife and saw to remove the steaks.

e. Cushion roast from the picnic.—The picnic is the lower half of the pork shoulder. It includes the shank and arm sections. The bone structure in the picnic shoulder makes this cut a difficult one to carve if it is cooked with the bones in it. Prepared as a cushion picnic roast, this section of the shoulder will present no carving problem.

(1) Remove the hock and collar as described in *b* above.

(2) "Tunnel" out the arm bone. To do this, cut around the ends of the arm bone from each side of the roast. Removing the bone in this fashion leaves a good pocket in the boneless arm meat.

(3) Take the skin from the hock. Cut the meat from the shank bones. Grind the boneless meat.

(4) Fill the pocket in the arm section with the ground shank meat. Tie two strings around the roast to help hold the ground meat in the pocket.

f. Carving Boston butt roast.—The Boston style butt is the top half of the pork shoulder. The bladebone may be removed from the Boston butt before roasting, but if this is done the meat does not hold together very well when the boneless roast is carved. Consequently it is recommended that the Boston butt be cooked with the bladebone in it. After roasting, it is a simple matter to run the carving knife under the blade and lift the bone to one side. The few ounces of meat attached to the blade and the ridge of the blade can be separated from the bone with a small boning knife. The meat underneath the bladebone is one solid piece which will carve easily.

g. Boneless roast from pork loin.—A practical way to use the pork loin as a roast is to remove the bones before cooking. This assures an easily carved roast.

(1) Strip the tenderloin from its cradle of bones along the backbone.

(2) Remove the small section of bladebone from the shoulder end of the loin provided this is not a bladeless loin.

(3) Loosen the loin meat from the feather bones by cutting closely along these bones the full length of the loin.

(4) With inside of loin up, separate the hip bone from the backbone by running the knife through the slip joint. Lift hip bone from meat by cutting closely around it.

(5) Turn the loin over so that it rests on the backbone with the loin strip next to the cutter. Separate the strip from the ribs and finger bones.

(6) Cut across the center of the boneless loin strip to separate the meat into two pieces of equal length.

(7) Lay the two pieces together, fat sides out, with the thick ends at opposite ends of the boneless roast. Tie the two pieces together with cords spaced about 3 inches apart.

(8) The tenderloin may be tied in with the boneless roast, or it may be cooked separately. The backbone may be used for another meal.

h. Boneless chops from pork loin.—The customary procedure is to use a knife and cleaver to cut pork chops. Unless the cleaver is very sharp, and the man who is wielding it skilled in its use, the pork chops are very likely to be full of bone splinters; also a large percentage of them will be thin on one side and thick on the other, thereby eliminating all possibility of cooking the meat uniformly. All of these difficulties can be overcome by using a saw instead of a cleaver, or by removing the loin strip and tenderloin from the backbone so that boneless chops can be served.

(1) Steps (1) to (5), *g* above, describe the making of a boneless loin roast and how to separate the tenderloin and loin strip from the bones in a pork loin.

(2) The tenderloin may be cut into pieces about 2 inches in length, then stood on end and flattened (frenched) with the flat side of a cleaver.

(3) For attractive boneless loin chops, cut them in double slices. The loin strip should rest on the block, fat side up. If chops one-half inch thick are desired, make a slice that thickness, stopping the knife before it goes entirely through the meat. The second slice should be the same thickness as the first one, but cut all the way through the meat.

(4) Open out the two pieces of meat. This cut is called a butterfly chop.

i. Cutting spareribs into individual ribs.—The object of the following instructions is to show a practical method of cutting spare-ribs that will not only provide attractive servings, but at the same time will eliminate disagreeable bone splinters.

(1) Remove the breastbone with a knife by cutting through the cartilages that connect it with the ribs.

(2) Slice between the ribs.

(3) It is recommended that each rib be separated from its neighbor before cooking, but if desired, two or more ribs may be left attached together.

(4) The important thing to remember is to avoid cutting across

the center of the ribs with a cleaver; the cleaver cannot help but make bone splinters. Bone splinters are not only a nuisance but they are dangerous.

j. One roast from light fresh ham.—A light, fresh ham (leg of pork) weighing less than 12 pounds, like a light shoulder, may be made into a single boneless roll that will be about the right size for roasting. The following steps illustrate an easy method of making the boneless fresh ham roast:

- (1) Remove the hock at the stifle joint.
- (2) With a knife, lift the skin from the outside. A "skinned" ham will have only a narrow collar, while the outside of a "regular" ham will be covered with skin.
- (3) Trim meat from outside of aitchbone. Remove the aitchbone by unjointing it from the leg bone and cutting it free from the leg meat.
- (4) Split the inside muscle over the top of the leg bone.
- (5) Run the knife lengthwise through the inside muscle, with the tip of the blade sliding along the cushion side of the leg bone. Cut meat free from leg bone so that the bone can be lifted from the meat.
- (6) Remove the kneecap from the shank end of the knuckle side of the ham.
- (7) Roll and tie the boneless meat into shape.

k. Two roasts from heavy fresh ham.—When the fresh ham weighs much more than 12 pounds, it is advisable to make it into two boneless roasts. The two rolls will be uniform in size and of a thickness that will be very satisfactory for roasting.

- (1) Separate the hock at the stifle joint.
- (2) Remove skin from outside of ham.
- (3) Take out the aitchbone by unjointing it from the leg bone and cutting it free from the meat.
- (4) With the face or inside of the ham up, split it lengthwise into two equal-sized pieces.
- (5) The cushion piece will be thick in the center, and the end where the aitchbone was removed will be fairly thin. Lay the thick part of the cushion over the thin end. This is done by starting at the shank end and cutting a layer of cushion meat that will be thick enough, when folded over the thin end, to make the roll uniform. Stop the knife before the cushion slice has been cut free.
- (6) Tie a few cords around the cushion roast to hold it in shape.
- (7) Remove the leg bone and kneecap from the knuckle half of the split fresh ham.
- (8) Tie with four or five pieces of cord.

26. Smoked meats.—*a. General.*—Smoked meats play an important role in the Army menu, especially during field maneuvers when refrigeration facilities are limited. Properly cured hams and bacon cannot be classified as nonperishable, but they can be kept much longer without refrigeration than could possibly be expected of a piece of fresh meat. In the packing house the supervision of the cellars and the curing of meat cuts is considered a very essential phase of the plant operations, and it is work that requires close and constant attention.

b. Curing and smoking meat.—For Army use bacon is dry cured or dry salt cured. Hams are sweet pickle cured. After the curing process is completed the meat is sent to the smokehouse. Here it is hung in rows over smouldering hardwood fires.

c. Kinds of smoked meat.—The principal smoked meats are: hams, bacon, picnics, shoulder butts, jowl squares, briskets, and beef ham sets (dried beef). There are two styles of smoked ham: regular and skinned. The regular hams are marketed with the outer skin and fat remaining intact. The name "skinned ham" is self-explanatory. It means that about half of the outer skin and part of the fat were removed before the ham was smoked. Smoked picnics (calas) are pork shoulders with the butt portion removed just beyond the knuckle bone. Shoulder butts are boneless. They are made from the eye muscle of the Boston style butt. The term "bacon" is applied to smoked bellies, though jowl squares and briskets are sometimes referred to as bacon squares and bacon briskets. Canadian style bacon is made from the boneless loin strip.

d. Quality of smoked meat.—Nearly all packers make from one to three grades of most of the smoked meat products. The grade of the finished product depends upon the curing method, quality of the fresh meat, and the way it was trimmed. Fancy bacon and hams are cut from the best quality pork and have smooth, thin skin and firm white fat. The meat is fine grained and bright colored. The bacon is free from "seeds." The lower grades are usually defective in one or more of the preceding characteristics.

27. Cutting smoked meats.—*a. General.*—Smoked hams and picnics are the only two cuts of smoked meat that will require much consideration from the standpoint of proper cutting. Both pieces of meat may be cooked unboned, but the bones complicate the carving job. For that reason it is often advisable to remove the bones before cooking.

b. Boneless smoked ham for baking.—The following method of removing the bones from the smoked ham is recommended for Army use:

(1) Use the knife to lift the skin from the outside of the ham, provided it is a regular ham. If it is a skinned ham, remove the collar and the skin that covers the shank.

(2) Remove the aitchbone by unjointing it from the leg bone and cutting it free from the meat.

(3) The shank may be removed at the stifle joint, provided it can be used to advantage in the preparation of some other dish; otherwise it may be left attached to the ham. In (4) to (6) below it is assumed that the shank is on the ham.

(4) Start at the small end of the shank and split open the top half (face) of the ham by running the knife closely along the shank bone, then the leg bone. Remove these bones as well as the small kneecap bone.

(5) The shank meat is so much thinner than the balance of the ham that it is advisable to cut off this meat and put it in the pocket left by the removal of the aitchbone.

(6) Roll and tie the boneless ham before baking.

c. Slicing smoked ham.—Slicing an unboned smoked ham not only involves a lot of work (unless the kitchen is equipped with an electric meat cutter) but it is not the most advantageous way to cut the ham into attractive servings. The method followed by most first-class hotels and restaurants is a more acceptable one.

(1) Take off the skin.

(2) Remove the aitchbone.

(3) Cut boneless slices from the meat that is exposed by removing the aitchbone. The slices should be made diagonally across the end of the ham until the leg bone is reached.

(4) Stand the ham on the cut surface of the butt end, with the cushion side on the right. Start at the end of the shank and cut down along the shank and leg bones until the block is reached. The cushion side of the ham can now be sliced into attractive horseshoe-shaped slices.

(5) Run the knife through the stifle joint to separate the shank from the knuckle side of the ham.

(6) Cut closely around the leg bone so that this bone may be lifted from the meat. Also take out the small kneecap bone.

(7) Turn the knuckle piece onto cut surface. Start at the large end and cut the entire piece into boneless slices.

d. Boneless smoked picnic for baking.—The smoked picnic probably will be used largely for seasoning and baking. In order to get the greatest number of attractive servings from this cut of meat, the bones and skin should be removed before cooking.

(1) Remove the skin.

(2) With fat side down, split open the picnic, following over the top of the shank bones and the arm bone as nearly as possible. Continue cutting until the meat has been freed from the bones and the bones can be removed from the meat.

(3) Fold the boneless meat together and tie with cord.

28. Veal.—*a. General.*—Veal is the flesh of calves. Milk-fed veal is considered best. According to Federal specifications, the minimum weight of dressed veal for the Army is 75 pounds, maximum weight 190 pounds. The moisture content of veal is high and its protective covering of fat is quite thin. Therefore, hanging or aging is not advisable. It must be ordered fresh and used promptly.

b. How to judge quality of veal.—The shape or general build of the carcass is the first thing to consider in judging quality of veal. The same thing is true of other kinds of meat. Good quality veal is plump and blocky; the neck and shanks are short; the rounds are full; the shoulders thick; and the rib and loin well fleshed. The carcass is thinly covered with clear, firm, white fat and the flesh is firm and light grayish in color. The kidneys should be covered with firm fat.

c. Place of veal in Army menu.—Two factors recommend veal as an article of diet in the Army menu. These are: tenderness and variety. Veal is a wholesome, nutritious meat, and being from a young animal it is always tender. The delicate flavor of veal is relished by many.

29. Cutting veal.—*a. General.*—The bone structure of veal is identical with that of beef. (Compare the veal bone structure chart (fig. 18) with the beef bone structure chart (fig. 3).) The names of the wholesale market cuts and the way they are made in the packing-house are very similar to lamb. Figure 17 shows the location of the major cuts in a side of veal. Normally, the carcass is not split but is sold as legs, loin, rib, and triangle, or a combination of these cuts such as the saddle and rack.

b. Veal for Army use.—As a general rule, the entire veal carcass may be utilized in much the same way as lamb; namely, the triangle for stew and the long saddle for roasts. The back section (shoulders, rack, loin, and legs) also may be cut into chops and steaks. The actual making of boneless veal cuts for Army use, however, will involve a combination of beef, lamb, and pork cutting methods. The reason for this is obvious when it is realized that a light veal weighs slightly more than a heavy lamb. A heavy veal weighs about the same as a medium-weight dressed hog and a little under one-half the weight of

VEAL CHART

LOCATION AND NAMES OF WHOLESALE CUTS

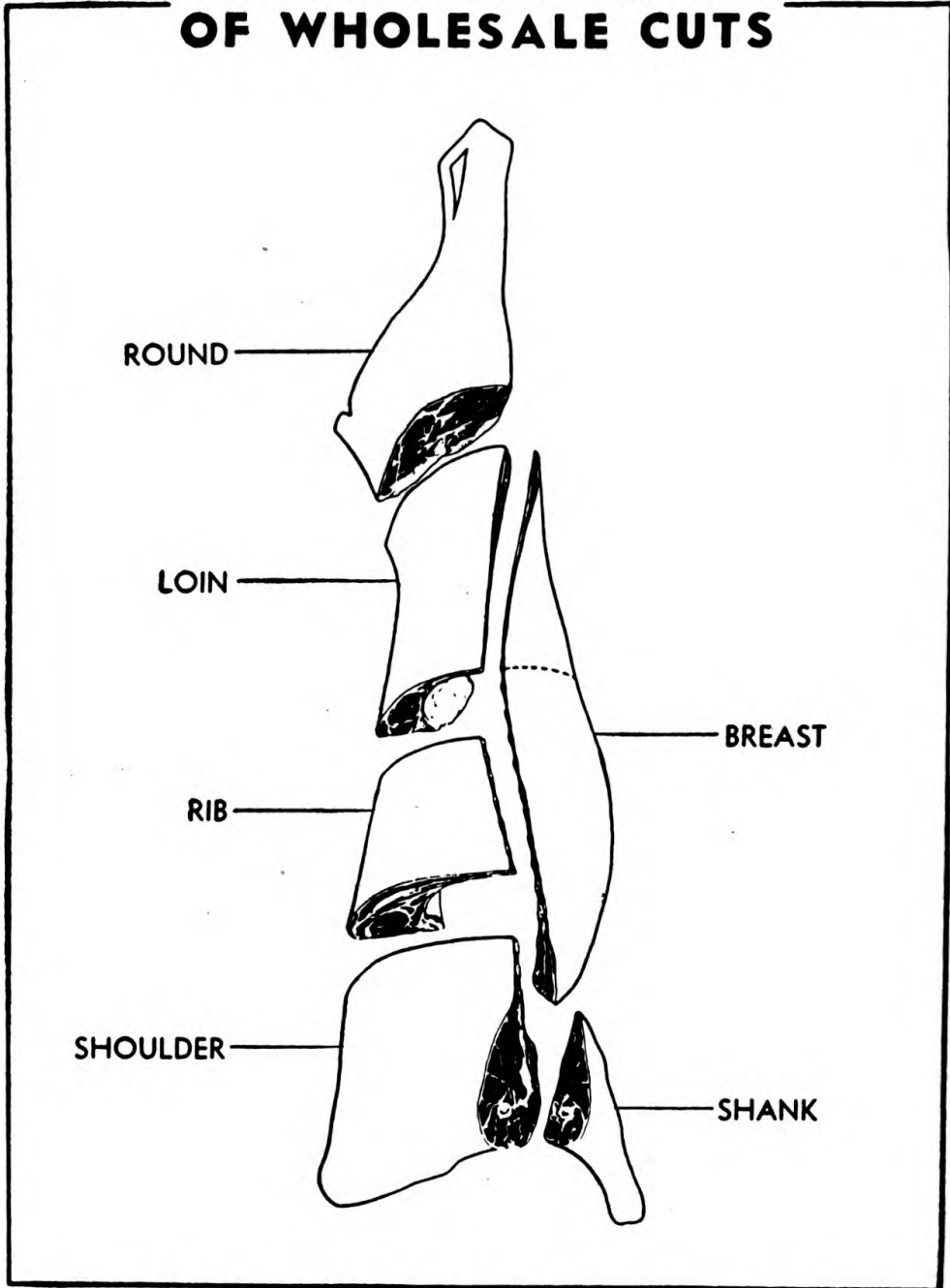

Prepared for the United States Army by the
NATIONAL LIVE STOCK AND MEAT BOARD

FIGURE 17.

VEAL CHART

LOCATION, STRUCTURE AND NAMES OF BONES

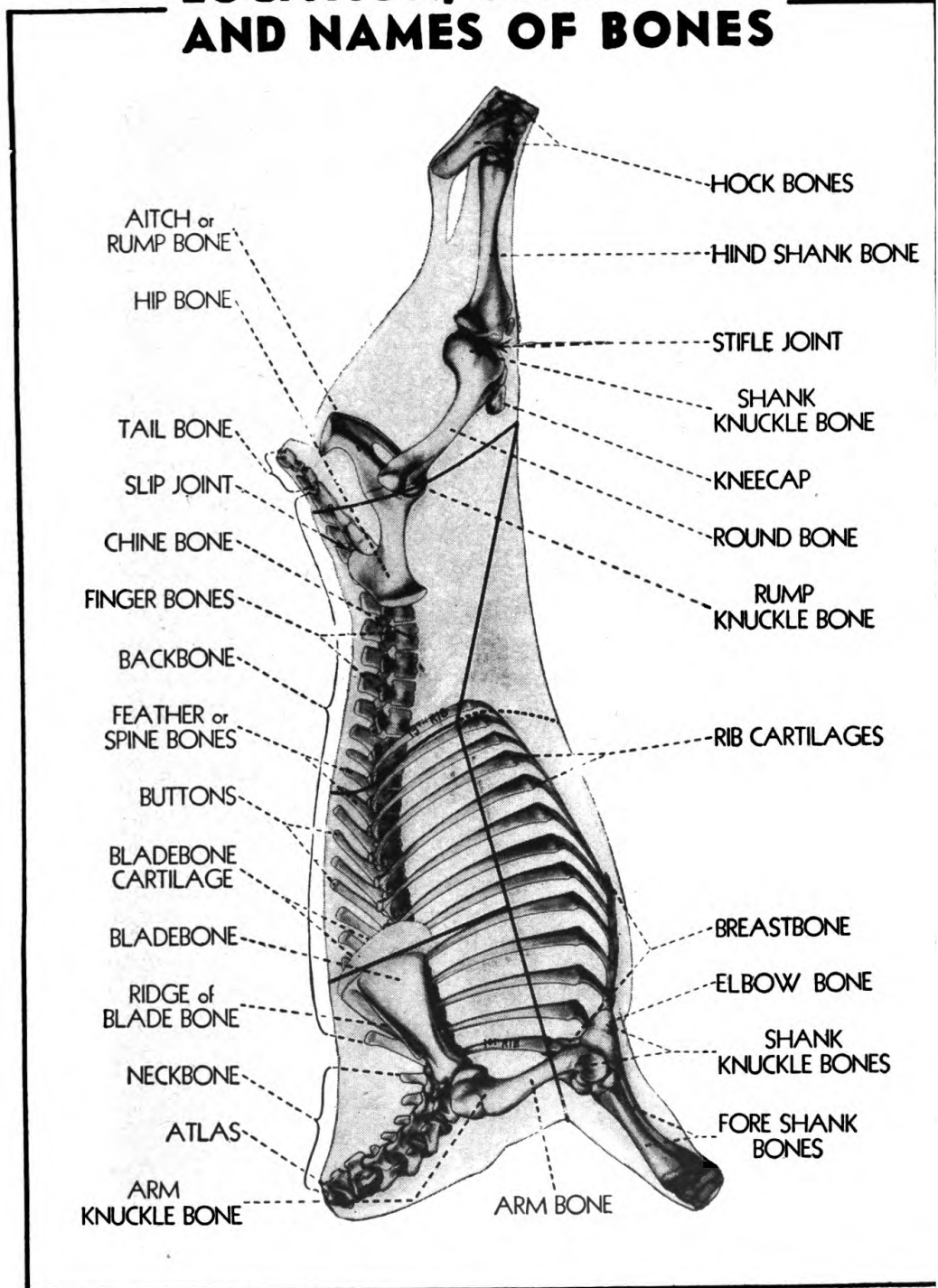

Prepared for the United States Army by the
NATIONAL LIVE STOCK AND MEAT BOARD

FIGURE 18.

a light carcass of beef. From this it can be seen that the weight of the veal carcass will influence materially the cutting method to be followed.

c. Light veal.—Light veal carcasses weighing less than 100 pounds may be cut into boneless roasts and boneless stew in practically the same manner as recommended for lamb (par. 23). The roasts will be somewhat larger in circumference than the comparable lamb roasts, but they will not be too large to cook satisfactorily.

d. Heavy veal.—A heavy veal carcass, or heavy saddles and racks, should be split down the center of the backbone, the same as beef. The usual procedure is to saw through the tail bone and sacral vertebrae, then use a cleaver to finish splitting the backbone. The forequarter is usually separated from the hindquarter between the twelfth and thirteenth ribs. There is no reason, however, why all 13 ribs should not be left on the forequarter.

(1) *Forequarters.*—The method described for cutting the forequarter of beef (par. 20*d*) will be the most satisfactory method to follow in boning heavy veal forequarters. This method will supply the greatest number of solid pieces of meat for roasts, if a maximum amount of roasting meat is desired. At the same time it is an easy way to bone the forequarter when only meat for stewing is needed.

(2) *Hindquarters.*—The heavy veal hindquarter should be divided into four major cuts: flank, market round (round with rump off but with knuckle attached), hip (loin end and rump), and short loin. The tenderloin should be removed before the hip and short loin are separated.

(*a*) The flank will be used for stew, or for a dish other than a roast.

(*b*) If the market round is a large one it should be divided into four pieces (knuckle, inside, outside, and heel) as recommended for beef (fig. 10). If the round is of medium size it may be split into two boneless rolls as recommended for a heavy fresh ham (par. 25*k*).

(*c*) The hip (rump and loin end) should be boned in one piece. The resulting boneless veal butt will make an excellent roast.

(*d*) The loin strip should be removed from the backbone of the shell loin. (A short loin with the tenderloin out is a "shell" loin.) Sometimes it is advisable to tie two loin strips together for roasting so that less meat will be exposed to the oven heat. This plan is comparable to the way a boneless pork loin is prepared for roasting (par. 25*g*). The same suggestion applies to the tenderloin.

30. Meat specialties.—*a. General.*—The name "meat specialties" is given to those edible parts of beef, veal, pork, and lamb which cannot be classed with the regular cuts. They are known also as "extra-edible parts," "fancy meats," "meat sundries," "variety meats," etc.

Use of these specialties is desirable because they introduce variety in the menu. They are economical. In addition, they furnish the same food elements found in muscle meats, and in some cases are extraordinary sources of these nutrients, being rich in vitamin A and in the vitamin B group. Because of their high moisture content and their lack of fat, these organs do not keep well and should be kept in the refrigerator until time to use them. There is little waste in these meats, and being boneless, it is easy to figure the number of pounds needed for one meal.

TABLE OF MEAT SPECIALTIES

Name	Characteristics	Cooking methods
Brains: Calf, lamb, pork, beef.	Very tender, soft in consistency-----	Precook. Cream; scramble; fry.
Heart: Veal, lamb, pork, beef.	Muscular organ which has had considerable exercise. Boneless; high percentage edible. Beef heart largest.	Stuff and braise. Cook in water.
Kidneys: Veal, lamb, pork, beef.	Surfaces of all kidneys are smooth and moist. Veal and beef kidneys characterized by irregular depressions in surface.	Cook in water. Stew; broil.
Liver: Veal, lamb, pork, beef.	Beef liver largest. Pork liver highest in iron. All excellent sources of essential nutrients.	Braise; fry; broil.
Oxtails, beef -----	Well flavored. Considerable bone-----	Soup; braise.
Sweetbreads: Veal, beef, lamb.	Great delicacy. Tender. Thymus gland of calf, young beef, and lamb. Divided into two kinds: heart and throat sweetbreads.	Braise; fry; broil.
Tongue: Veal, lamb, pork, beef.	Pork, lamb, and veal tongues are usually sold in a ready-to-serve form. Beef tongue may be purchased fresh, pickled, corned, or smoked. Boneless; high percentage of lean meat.	Cook in water.

b. Sweetbreads.—These are the thymus glands of beef, veal, and lamb. Veal sweetbreads are larger than those from beef. As the animal matures, the anterior part called “throat sweetbreads” disap-

Public Domain, Google-digitized / http://www.natntrist.org/access_use#pd-gooole

pears, but the posterior part known as "heart sweetbreads" is used. Calf sweetbreads are more valuable commercially. Swine (pork) do not have sweetbreads, while those of lamb are too small to have any commercial value.

c. Brains.—Brains and sweetbreads are much alike in tenderness and texture, and may be used in much the same way. An occasional mess including brains is looked upon with favor by Army men.

d. Hearts.—Veal, lamb, and pork hearts are tenderer than those from beef. They are also smaller. The heart is a muscular organ and the meat is fibrous. Beef hearts contain a small piece of cartilage near the top center. This should be removed. Beef hearts should be given long, slow cooking to make them tender.

e. Tongue.—Like hearts, the tongue receives considerable exercise and, before it is cooked, is one of the least tender of meat specialties. Veal and beef tongues are larger than those from pork or lamb. Tongue is sold fresh, pickled, corned, or smoked.

f. Kidneys.—This variety meat is prized highly. Kidney stew especially has become famous. Kidneys should be of a dark red color, firm texture, and free from strong odors. Pork, beef, veal, and lamb kidneys are equally satisfactory for mess use. If kidneys have a strong odor, this can be removed by slicing and soaking the meat in salt water for several hours before cooking. While the kidneys taken from a beef carcass are not sufficient in quantity by themselves for a meal for the mess, they can be used to good advantage in lean beef stew, potpie, or in soups and gravies.

g. Liver.—Liver is a very rich source of iron and other substances concerned in the formation of red blood cells. It also is an excellent source of vitamin A and the B complex. The flavor of liver is enhanced by serving it with bacon. Pork and lamb liver should be scalded before cooking; beef and veal liver need not be. Beef livers should be full, short, thick, and tender, of a dark mahogany color, have the gall bladder removed, and be free from bile stains.

h. Oxtails.—While they have considerable bone, oxtails also have a goodly portion of meat and are very rich in flavor. Oxtails require long, slow cooking in moist heat to make them tender and are used for soup or prepared by braising. Before preparation, they should be cut into pieces at each joint.

31. Frozen meats and fish.—*a.* In time of peace, beef, veal, lamb, mutton, pork, poultry, and fish may be delivered to Army messes in either a chilled or frozen condition. "Chilled" means that the meat has been held in a chill room until it reaches a temperature of 34° to 36° F. "Frozen" means that meat has been held in a freezing

room, often called cold storage, at a temperature usually below zero until solidly frozen to the center. In the continental United States, meats, poultry, and fish normally are received by messes in a chilled condition. In the Tropics they sometimes are frozen when received. In time of war they may be received in frozen form both in the Tropics and elsewhere.

b. Frozen meats and fish should never be thawed in water, as this soaks out some of the meat juices, which reduces palatability and food value.

c. While it is possible to thaw in ordinary room temperature, this is bad practice and should be resorted to only when there is not time to thaw in a refrigerator, because by the time the meat, poultry, or fish is thawed to the center the outside may begin to spoil. This spoilage is evidenced first by a slimy surface, and there may be a slight tainted odor; these evidences of spoilage increase as time goes on, and eventually the spoilage reaches such a stage that the surface must be trimmed away. The best method of preventing surface spoilage while thawing is to thaw at a temperature slightly above freezing (up to 40° F.). This requires longer time but is safe. Regardless of the temperature of thawing, there should be a good circulation of air around the frozen product being thawed. This is because moisture appears on the surface while thawing, and moisture favors spoilage. If the air around the thawing meat is kept moving it carries away the moisture and the meat remains dry and in better condition.

d. If there is not sufficient room in the refrigerator to permit hanging a quarter of frozen beef or a carcass of veal, it must be divided. This is not particularly difficult. It can be done with a meat saw. It is less difficult if thawing is allowed until cutting down to the bone can be done with a knife, but this method is not recommended in a warm room.

e. When using frozen meats, the time required for thawing must be considered in planning cooking operations. For example, if roast beef is to be served on Sunday, the frozen beef should be delivered Thursday or early Friday morning. Following are approximate times required for thawing in an Army mess refrigerator:

	<i>Hours</i>
Frozen beef, quarters, chucks, or rounds.....	36-48
Frozen beef, loins, ribs.....	36-48
Frozen veal, mutton, or lamb carcasses.....	24-36
Frozen veal, mutton, or lamb cuts.....	18-30
Frozen pork, cuts.....	18-30
Frozen poultry or whole fish.....	12-24

f. Thin cuts of frozen meat, that is, cuts not more than 1 inch thick, may be satisfactorily pan fried by putting the frozen cuts directly into the hot pan without first thawing them. In pieces of this size the frost is quickly driven out, and the interior becomes cooked before the outside is overcooked. However, if the thin cuts are to be fried in deep fat, they must first be thawed. If this is not done, the cold in these cuts will cool the fat below the proper frying temperature. About the only thin frozen cuts used in Army messes are frozen fish fillets, and when cooked without being first thawed they are more palatable.

g. When frozen meats are supplied to troops in the field as part of the field ration, usually there will be no refrigerator in which to thaw them. They must be thawed in the open, the rapidity of thawing depending on weather conditions. In hot weather the surface of the meat will begin to spoil before the meat is thawed at the center. This spoilage may be retarded by hanging wet cloths or sacks around the thawing meat. The wind blowing on these wet sacks will keep the meat cooler than the surrounding atmosphere. Sometimes frozen meat will be received in the field only a short time before it must be cooked for the next meal. In such a case a stew may be made, using the chuck, shanks, or round. The meat saw and cleaver must be used to cut off these cuts. In hot weather cooked meats will keep longer than chilled fresh meat, and when necessary to save meat to prevent loss through spoilage, the cook should not hesitate to cook more meat than is needed for immediate service.

h. Frozen Army boneless beef should be thawed in the boxes in which it is packed. Because of the frost in the meat, the box becomes the equivalent of a refrigerator and keeps all the meat refrigerated while defrosting is taking place. The surface of the meat is not exposed to the warm air of the room and surface deterioration (slime) does not develop.

32. Sausage.—*a.* Commercial sausage is made from finely chopped or ground meat (or meat products) to which cereal (as flour or corn meal) may or may not have been added, and flavored with spices and condiments. It usually is stuffed into a casing. Federal specifications do not permit the Army to purchase sausage to which cereal has been added. The presence of any cereal must be declared on the label, and when over 3 percent of cereal is present the product must be labeled "Sausage and Cereal." Sausage containing cereal should not be accepted by Army messes.

b. Fresh pork sausage is made from fresh pork trimmings and should never be eaten raw. It should be cooked until well done.

c. Cooked and smoked sausages, such as bologna, frankfurters, etc., are made from combinations of beef and pork trimmings and meat products.

d. Dry sausage includes all summer sausages which are made from pork and beef trimmings and for the most part are preserved by drying. Some varieties of summer sausage are smoked. Dry sausage containing lean pork, prepared in an official establishment, is prepared in one of the ways prescribed by the Bureau of Animal Industry to kill any trichinae that might be in the pork. No dry sausage should be used unless it was prepared in an official establishment.

33. Fish.—*a. General.*—Fish may be served broiled, fried, sautéed, baked, or in salad. Fish are very perishable and for this reason great care should be taken to avoid serving any which are not in good condition. All fish should be carefully inspected when received in the mess and again before being cooked or served, if kept very long. Fish may be classed as fresh, stale, or putrid, as described below. Only strictly fresh fish should be accepted or served by the mess. Fresh fish, if not frozen, should be delivered to the mess packed in cracked ice. For inspection and handling of frozen fish, see paragraph 31.

(1) *Fresh fish.*—Fresh fish have a bright appearance; the scales are firmly adherent and glittering; the natural slime, if present, is that common to the species; the eyes are outstanding and full; gills and mouth closed; blood in abdomen bright with no off odor; abdominal walls firm and elastic with no discoloration; flesh firm, elastic, and tight on the bones; when placed horizontally across the hand the fish does not bend; when placed in water it sinks.

(2) *Stale fish.*—Stale fish have a duller appearance than fresh; scales are more or less easily removable and slightly slimy or smeary or may be abnormally dry; eyes red bordered; surface of eyeball cloudy; gills pale yellow, dirty or grayish red, and covered with slime of disagreeable odor; blood in abdomen dull in color and may have slight off odor; abdominal walls becoming soft and flabby; body bony and bends easily especially at the tail end; finger impressions easily made and remain; meat somewhat soft and more easily discolored. When placed in water a stale fish floats.

(3) *Putrid fish.*—All the brightness gone; dull, lifeless color; scales very loose and covered with a smeary, slimelike mass of very disagreeable odor; eyes breaking down or gone; all bright color gone from the gills which have an extremely offensive odor; body withered and flabby; abdominal walls soft and pulpy with apple-jelly-like

appearance and discolored; meat soft; abdomen bloated; body blood dirty brown in color and with offensive odor. A putrid fish floats when placed in water.

b. To clean fish.—(1) *Scaling.*—The scales are removed with a knife held at such an angle that the blade will work under the scales as the knife is pushed in the direction of the head from the tail, with short, quick motions.

(2) *Removing entrails.*—With a pointed knife cut the entire length of the belly from the vent to the head, taking care not to cut the entrails. Cut the head from the body, starting from the belly side. The entrails can then be removed by hand. In some small fish it is possible to remove the entrails with the head by opening the belly, then loosening the head by cutting from the back, and pulling in the direction of the vent. After the entrails have been removed the fish should be wiped thoroughly, inside and out, with a cloth wrung out of cold water. There may be some clotted blood near the backbone that cannot be removed in any other way than by wiping.

(3) *Skinning.*—Eels and bullheads do not have scales and are usually skinned. The fins along the back should first be removed with a sharp knife or scissors. Make a cut, skin deep, along the entire back; grasp the skin on the back, just back of the head, between the thumb and a knife blade and pull downward and backward. The skin will usually come off in a sheet. If the flesh is tender, care should be taken not to tear it by pulling too quickly. In skinning bullheads it may be necessary to fasten the fish by the head by hanging it on a hook or by driving a nail through the head, because the skin is tight to the flesh and it takes hard pulling to remove it. It may be necessary to use a pair of pliers for this purpose.

(4) *Boning.*—Haddock, cod, halibut, whitefish, etc., are quite easily boned. After the fish are scaled (or skinned) and cleaned, run a sharp knife along each side of the backbone from the tail to the head and pull back the flesh from the backbone. Any small bones that cannot be removed readily with the backbone may be pulled out by the fingers. Another method of boning is to dress the fish and remove the head, then grasp the backbone at the head end with one hand and pull the flesh away from the backbone with the other. Pull out all loose bones that have not been removed with the backbone, and/or scrape over the flat surface of the inside of the fish with a knife.

34. Poultry.—*a. General.*—Poultry includes those birds which are usually raised on farms for their flesh and eggs. The principal

classes of poultry are chickens, turkeys, ducks, and geese. Turkey is included in the ration for Thanksgiving Day and for Christmas, but chicken is the class of poultry most used in the mess. Ducks and geese are seldom used in Army messes. Ducks yield a smaller amount of food than any other class of poultry and are usually high in price. Geese are usually less expensive and yield a good proportion of edible meat, but are not so popular because of their supposed greasiness. When cooked properly, roast goose is very tasty and a desirable change from the other classes of poultry. Ducks and geese have no white meat such as is found on the breasts of turkeys and chickens. Chicken is the only class of poultry which is commonly served to the mess fried or fricasseed.

b. Chickens, kinds and uses.—There are four principal classes of chickens: broilers, fryers, roasters, and fowl. Broilers and fryers are young birds with tender flesh and are best suited for broiling or frying. They are too small to roast satisfactorily and have too little fat on them to be used for stew or fricassee. Fresh broilers can be found on the market during June and July, and fresh fryers during July, August, and September of each year. At all other seasons fresh broilers and fryers are both scarce and expensive, but they may be procured from cold storage during this time, if desired. Fowl and roasters best meet the needs of the Army mess. Fowl, which are fat hens over 1 year of age, are usually somewhat tough and therefore used for stew and fricassee. The best grades of hens are sold as fowl and usually are kept in cold storage; stewing hens are the poorer grade. They can be bought fresh at any time of the year. Roasting chickens are quick-grown young cockerels. Their meat is tender, and they are excellent for roasting. Fresh roasters are found on the market from September to January; at other times frozen roasters may be procured. Cocks (old roosters) and stags (male birds with marked masculine characteristics) should never be used by Army messes. Age is determined by the size and development of the birds, the condition of the shanks, claws, and spurs, and the condition of the cartilage of the breastbone. Young birds are lankier and rangier than mature (old) birds, and the head, wattles, and comb are undeveloped. The shanks (lower leg) of young birds are smooth and bright, while with increasing age the shanks become roughened, scaly, and dull colored. On broilers the spur is scarcely noticeable; on fryers it shows as a small rounded knob; on roasters the spur is more prominent, but not hard; on stags the spur becomes longer and harder. The claws of young birds are short, slender, and pointed, while on old birds they become long,

dull, and stubby. The cartilage at the rear (lower) edge of the breastbone is soft and pliable in young birds while as the bird grows older this cartilage gradually turns to bone and becomes firm and rigid. Cockerels and cocks have a greater development and usually deeper color of wattles and comb and larger heads than pullets and hens. Hens have a deeper, broader body, especially in the abdomen, than cocks. The shanks and thighs of hens are much slenderer than those of the male birds, and the spurs of the hen are small and undeveloped. The neck, back, and tail feathers of the cock are usually much heavier than those of the hen. A cook should be able to recognize readily the different classes of birds in order that he may determine which is the best manner of cooking and serving them.

c. Turkeys, kinds and uses.—Army specifications prescribe only young turkeys for use in the mess. Here again age is reflected in the size of the bird, condition of the breastbone, size of the dewbill and beard, size of the spurs, and color of the legs. Young toms are more rangy and leggy than hens. Hens have short, plump bodies; small, short legs and wings; small heads with small dewbills (the fleshy growth just above the beak), and either a small beard or none at all. Old toms have a long, coarse beard, prominent dewbill, and large, heavy spurs. The beard begins to grow on the breast of the male turkey at the age of 2½ months, and at 1 year old is from 3 to 5 inches long, becoming longer each year. When about a year old, the turkey hen begins to grow a beard, but it is always short compared with that of the tom. The dewbill is always larger and more elastic in the male (tom) than the female bird. Young toms have only a short, blunt knob on the inside of the shank, while old toms develop a stout spur. The hen turkey has only a small rudimentary spur or button. Turkeys' feet are said to be black up to 1 year of age, assume a pinkish color up to 3 years, and then gradually turn a dull gray. The breastbone cartilage of the young turkey is always soft and pliable, gradually becoming hard and firm as age advances.

d. To draw and clean poultry.—(1) The poultry received by the Army mess usually has been killed and bled, then dressed and chilled or frozen. Dressed means that the feathers have been removed, but dressed poultry practically never has been drawn (entrails removed); therefore, if the mess receives dressed poultry it is necessary to remove the entrails after receipt. If the entrails have been removed before being received by the mess, the poultry is called dressed and drawn. Before drawing a bird the skin should be cleaned. The fine hair found here and there on the skin can be easily removed by

singeing. This is done by holding the bird for a moment over a gas flame, or any other clean flame, and turning it so that all portions of the skin come in contact with the flame. Pin feathers are removed by grasping them between the thumb and the blade of a paring knife and pulling them out. Next step (except in the case of turkeys) is to cut off the head with a cleaver or a heavy butcher knife and to remove the feet by cutting through the hock joint with a knife. All of the tough, coarse skin on the hocks should be trimmed off. The legs of turkeys contain a number of coarse tendons that are objectionable if not removed. To do this, loosen the skin and the ligaments on each side of the hock joint, and then twist the foot until it is free except for the tendons. Then by hanging the bird up by the feet and pulling straight downward, these tendons will pull out of the leg muscles and remain attached to the feet (shank). The first step in drawing a bird is to remove the crop, gullet, and windpipe. Slit the skin covering the crop crosswise with a knife, and loosen the crop all around with the fingers. Then cut the gullet below the crop and close to the breastbone, and remove the crop and neck part of the gullet by pulling. By thus removing these parts first, the entrails remaining can be drawn out more easily. The windpipe may have to be cut near the lungs to remove it readily, and should be pulled out at this time.

(2) Next cut from the rear of the breastbone to the vent (anus) and loosen the vent by cutting around it. Insert the hand into this opening, grasp the intestines as far forward as possible, and draw them out to the rear. All except the lungs should come out together. The giblets (heart, liver, and gizzard) should now be separated from the entrails and the remainder discarded. There is usually considerable fat attached to the intestines of geese which should be removed and used for cooking or rendering. The blood vessels should be cut away from the top of the heart. The gall bladder is attached to the liver and should be carefully removed to avoid puncturing. No bile should be allowed to come in contact with the meat, as this may impart a very bitter flavor which is hard to remove. The inlet (gullet) and outlet (intestine) of the gizzard should be cut as close to the gizzard as possible, and the gizzard opened by cutting through one side down as far as the sac which lines the gizzard. This sac may be entirely removed with the fingers if a little care is used and the sac itself is not cut. The gizzards of geese have two disks of cartilage on their inner surface, which generally should be removed by a knife. The lungs are easily removed. They are soft and pulpy and lie in the forward end of the cavity underneath the ribs and on either side

of the backbone. They have no food value and should be removed. The kidneys lie on either side of the backbone toward the rear of the cavity. They are not easily removed entirely, and may be left in, as they have some food value, and are palatable and edible. The oil gland (bag) just above the tail should be removed with a knife, care being taken to remove all of the gland. It can be distinguished from the surrounding tissue by its darker color. The drawn and dressed carcass is then ready for washing. It should be rinsed under a faucet, allowing the cold water to run through it and over it, washing off any stains or foreign matter. The carcass should never be soaked in water. If the bird is to be roasted, it is now ready to be stuffed. After stuffing, the cuts made for removing the entrails are sewed up and the bird is ready for the oven. If the bird is to be used for any other purpose than for roasting, it must be cut up. The wings, legs, and thighs are unjointed with a knife, and the remainder of the carcass cut into as many pieces as desired with either a knife or cleaver.

35. Dairy products.—*a. Milk.*—(1) *Fresh milk and buttermilk.*—Fresh whole milk should be served in the mess daily. Great care is exercised to insure that only wholesome milk is delivered to the mess. This same care must be exercised by the mess personnel after it is received at the mess. The milk is pasteurized to destroy disease micro-organisms. Fresh milk is an excellent medium for the growth of bacteria and is easily contaminated. Milk should never be delivered to the mess in bulk as continued dipping and mixing of air in the milk again introduces disease organisms. For this reason, milk should be delivered in half-pint bottles and issued to the soldier in the same bottle as received. Fresh pasteurized milk should be used in every mess whenever available, especially for breakfast, as the men prefer it for their cereal or for drinking. Buttermilk should be handled in the same manner as described above for fresh milk.

(2) *Evaporated.*—Evaporated milk is milk that was reduced to less than one-half of its original volume by the evaporation of water. It is usually issued to the mess in 14½-ounce cans which is sufficient to make 1 quart of whole milk by the addition of water. It may be used as it comes from the can, the same as cream. When diluted, it may be used the same as fresh milk. Evaporated milk keeps well if not exposed to high temperatures. It should be stored in a cool place and turned often to keep the cream from separating.

(3) *Dry.*—(a) There are two principal forms of dry milk. One is the dry milk containing all the butterfat and is known as “dry whole milk.” The other is the product from which has been removed all

fat which it is possible to remove. This product is sold as "dry milk solids not over 1½ percent fat," "dried skimmed milk," "skim milk powder," or "powdered skim milk." The dry whole milk is fresh, sweet whole milk, from which the water has been removed. It is a cream-colored powder, containing 26 to 27 percent butterfat. "Dry milk solids not over 1½ percent fat" is fresh, sweet milk from which both fat and water have been removed.

(b) Because of the fat content, dry whole milk is subject to development of rancidity. When packed in vacuum or an inert gas, the oxidation of the butterfat is retarded and it may be stored for several months. Since the fat content of dry milk solids (skim milk) is very low, the milk does not easily deteriorate and can be kept for at least 6 months under ordinary conditions. Because dried milk readily absorbs moisture it should be kept in an airtight receptacle. If dry milk should become lumpy, the lumps should be broken with a rolling pin and sifted through a sieve.

(c) Dry milk may be used in dry form in almost any food. Remixing with water is not necessary unless it is used as a beverage or other dish containing a great deal of liquid. If it is desired to reconstitute dry milk, the best procedure is to place the necessary quantity of dry product on top of the water and stir until dissolved. Lukewarm water is usually best for this purpose—never hot water. Another method is to add a small quantity of water to the dry milk product, mix to a paste consistency, and then add the remainder of the water slowly.

b. Butter.—Butter, containing not less than 80 percent butterfat, has a high calorific value. Aside from its high calorific value it is one of the chief sources of vitamin A in the ordinary diet. Butter absorbs flavors and odors very readily and should not be stored with other foods unless well protected against the absorption of food flavors. It should be handled the same as fresh milk and kept in the refrigerator until time of serving.

c. Cheese.—There are two types of cheese on the market, the natural cheese and the processed or pasteurized cheese. The natural cheese is made from either raw or pasteurized milk which has been inoculated with a specific bacteria and seasoned to give it its characteristic flavor. Processed cheese is the natural cheese pasteurized and sold as "Processed Cheddar," "Processed Swiss," etc. The consumption of the two types is about equal. The processed cheese has a milder flavor than the natural cheese. It is usually packed in brick shapes of various weights and wrapped with specially treated paper. Both types of cheese have the same nutritive value. Cheese is high in

proteins and fat and should be served often in the mess as a substitute for meat. One or two varieties should always be included in cold suppers on Sundays or holidays. Processed cheese is usually higher priced than the natural cheese. However, there is no waste of rind to processed cheese and it is much easier to cut into economical servings. Considering these facts it may be as cheap to serve processed cheese as natural cheese.

d. Ice cream, ices, and sherbets.—Ice cream is a very satisfactory dessert, either summer or winter. Ices should not be confused with ice cream as they are usually made from water, fruit juices, and sugar. Sherbets are similar to ices but contain some egg white. Both ices and sherbets make a satisfactory dessert after a heavy meal, especially on a hot summer's day. Ice cream can be purchased from commercial concerns at reasonable prices and conveniently wrapped for individual servings, usually six or seven servings to the quart. If the equipment is available, ice cream, ices, and sherbets can be made in the mess at a considerable saving.

36. Eggs.—*a. General.*—(1) The term "eggs" unqualified, means hens' eggs. Hens' eggs average, when fresh, approximately 2 ounces each, of which weight the yolk represents 32 percent, the white 57 percent, and the shell 11 percent. The food value or flavor of the egg is in no way influenced by the color of the shell. The general color of the yolk varies with the feed. Green feed and yellow corn produce dark-colored yolks, while small grain and white corn produce light-colored yolks. The albumen (egg white) is held together by a very fine network of fibrous material radiating through it from the shell membranes. It is this network that enmeshes and holds the air when an egg is whipped. With age these fibers become weaker and do not retain the air so well. Consequently, an old egg does not whip satisfactorily.

(2) The most common deterioration of eggs, especially in warm weather, is due to germination. Fertile eggs will germinate at any normal temperature above 68° F. Fresh eggs, therefore, should be held at temperatures below 68° F. As eggs absorb odors, egg storage rooms must be kept sweet, clean, and free from foreign odors.

(3) If the egg whites are to be whipped, none of the yolk should be allowed to get into the dish as it keeps the whites from becoming fluffy. If many eggs are to be broken into a dish, they should be broken and dropped into a saucer, one by one, so that any bad eggs may be thrown out without spoiling the whole batch.

b. Dried eggs.—(1) There are three classes of dried egg products: dried whole egg, dried yolk, and dried albumen (whites).

(2) A good dried egg made from strictly fresh whole eggs has excellent keeping qualities, flavor, and aroma. It does not require refrigeration and can be stored at ordinary temperatures for several months. It is a product that will lend itself to field conditions where it is difficult to issue fresh eggs or where refrigeration is lacking. It is also adaptable to cold climates as freezing will not injure the product.

(3) It is not necessary to reconstitute the powdered egg for baking. The best method is to add it dry and incorporate it by creaming with the shortening in the formula. (See par. 6, app.)

37. Canned foods.—*a. General.*—Canned foods are fresh foods preserved by heating them in hermetically sealed containers. Canned foods are subjected to thorough heat treatments, which destroy the bacteria and other organisms that may cause spoilage at ordinary temperatures. There is a common impression that consumers of canned food are liable to ptomaine poisoning. Sterilized food in airtight containers cannot, under any circumstances, be dangerous.

b. Nutritive value.—Most of the nutritive value of the food is preserved with the product. In many cases the nutritive value will be higher than in the overcooked fresh vegetables. Much of the nutritive value of the food is dissolved in the liquid surrounding the product. For this reason the juices should be served with the food or used for sauces, soups, stock, or gravy. Canned sea foods are rich in iodine and vitamins A and D.

c. Preparation of canned foods.—Canned fruits and vegetables, as well as other kinds of canned food, have been thoroughly cooked in the canning process and require no cooking in the mess. If it is desired to serve canned foods hot, it is only necessary to heat them for a few minutes before serving. Canned foods should never be boiled or heated longer than necessary. Boiling or prolonged heating tends to destroy many of the vitamins. Most of the canned meat products on the market can be served without cooking. However, some of the pork products are only partially cooked and require additional cooking or roasting before being served.

d. Inspection of canned foods.—The containers of all canned goods should be inspected when issued to the mess. Swells (cans with bulged ends), leakers (containers from which juice has escaped), and badly rusted cans should be rejected. Slight rusting, dented, or soiled labels do not affect the quality of the food and are no cause for rejection.

e. Storage of canned foods.—The keeping quality of canned food depends, to a large extent, upon the nature of the product. The acid of certain fruits and vegetables reacts with the metal of the can,

causing pinholes. Many highly colored products fade and others disintegrate with time. The following points should be considered when storing canned goods:

(1) Dry storage with good ventilation.

(2) Cool storage. The ideal would be approximately 50° F.

(3) Avoid freezing temperatures. Frozen canned food is seldom ruined if the cans are not injured. However, there is some breakdown of the cell tissue and the product will not have as good an appearance as before freezing. If canned goods should freeze, do not defrost until you are ready to use them. Frozen canned foods should be thawed slowly.

(4) Canned fruits and vegetables of the acid type (cherries, berries, pineapples, plums, sauerkraut, etc.) spoil rather rapidly in warm temperatures and should not be kept on hand in the mess for more than 3 months. Canned fruits and vegetables of the nonacid type (apricots, peaches, pears, beans, corn, peas, pumpkin, etc.) keep well and may be stored under proper conditions for 6 months to 1 year. Canned meats are good keepers and may be stored for 1 year. Some canned pork products which have not been thoroughly cooked must be stored under refrigeration. Canned sea foods do not keep as well as canned meats and should receive frequent inspection. Canned milk should not be stored over 6 months and the cases should be turned frequently to prevent separation of the butterfat from the milk.

38. Cereals, breakfast.—*a.* There are three main types of breakfast cereals on the market:

(1) Uncooked—corn meal, farina, cracked whole wheat, etc.

(2) Quick cooking—cereals that have been partially cooked before packing and require but 3 to 5 minutes for preparation.

(3) Ready-to-eat—cereals which can be served without further preparation. Ready-to-eat cereals are of various types: flaked, puffed, malted, and shredded.

b. The uncooked and the quick cooking cereals are the lowest in cost and those made from whole grains give the greatest food value. They are of especial value in the mess on cold days or at times when considerable time elapses between the morning meal and noon meal, as this type of cereal seems to stave off hunger for a longer period.

c. The ready-to-eat cereals have their advantage in that they can be served without preparation by the cook. There is a wide variety on the market, most of which are packed in individual packages. The individual package is the most satisfactory unit for use in Army messes. A variety can be placed on the table and the soldier can

choose the cereal he prefers. There are no open packages left to protect against dust and insects or left-overs to worry about.

d. Both uncooked and ready-to-eat cereals should be used to give variety to the menu. During hot weather the soldier may prefer the ready-to-eat cereals. However, many prefer the uncooked cereals when fresh milk is not available.

39. Beverages.—*a. Coffee.*—Coffee is the most important beverage served in the Army. The coffee furnished to Army messes is of good quality and will make an excellent beverage, provided it has not lost its strength and the beverage is properly made. Coffee loses its strength rapidly after roasting and the loss of strength is hastened if the roasted coffee is ground. Loss of strength is retarded if roasted and ground coffee is kept in tightly closed containers. When practicable, coffee should be ground just before using in order to get the maximum strength from it. When roasted and ground coffee is purchased by the mess it should be purchased in amounts that can be used in 2 to 3 days. When making coffee, grounds once used should be discarded. A good cup of coffee cannot be made when fresh coffee is added to grounds already used. Coffee should never be boiled and the coffee utensils should be cleaned immediately after use.

b. Tea.—There are three general classes of tea: green (unfermented), black (fermented), and oolong (semifermented). Black tea is usually furnished for Army messes and is an excellent beverage if properly prepared. Pour freshly boiling water on the required amount of leaves in an earthen pot. Allow it to brew for 3 to 5 minutes, then remove the tea leaves and serve. Iced tea should be made in the same manner, except doubly strong and poured over cracked ice. The ice will melt and dilute the tea to its regular strength. If the hot tea is permitted to cool before the ice is added it will have a cloudy appearance. Tea will absorb moisture and odors, and the volatile oil will evaporate. Store tea in tightly covered cans and in a cool place.

c. Cocoa.—Cocoa is the ground cacao bean from which part of the fat has been extracted. "Breakfast Cocoa" must contain not less than 22 percent cacao fat and therefore is a more nutritious beverage than the product "Cocoa." Cocoa is an excellent medium by which to introduce milk into the diet. Cocoa is rich in starch, therefore cocoa boiled for 5 minutes has a much better flavor than that which is made by simply adding it to scalded milk.

40. Condiments.—*a.* A good cook depends on condiments to give flavor and relish to food. To obtain the desired results, spices are

added sparingly to give a hidden flavor and never in such amounts as to destroy the flavor of the food.

b. Spices are aromatic seeds, buds, bark, roots, and leaves of various plants used to season food. They may be used in ground form and mixed with the food or they may be used whole and withdrawn before serving the food. Whole spices are usually used in the preparation of soups, sauces, and pot roasts.

c. Salt should be added to the food when prepared for cooking. Vegetables should be cooked in salted water. The cook must be careful when adding salt as a little excess salt will ruin the product. Salt can be added to the food after it is prepared, but once added, it cannot be removed.

41. Corn meal and grits.—Corn meal is ground white or yellow corn with the hull removed and the fine corn flour sifted out. About the only difference between hominy grits and corn meal is that the corn meal is of a finer grind. Both can be cooked and served as a breakfast cereal or as a fried mush. The corn meal is used for corn muffins and corn bread. The grits are often used as a substitute for potatoes and served with gravy.

42. Extracts, flavoring.—Flavoring extracts are derived from two sources: plants, known as “true extracts,” and chemical compounds that produce the desired flavor and aroma for which the extract is named. Such flavors are called “synthetic” or “imitation” flavors. The true extracts have a more delicate flavor and aroma than the synthetic flavors. Most Army messes use only vanilla and lemon flavors. There are many more on the market and much interest can be added to the food by using a variety of flavors.

43. Fruits and vegetables.—*a. Fresh.*—(1) *Fruits.*—Fresh fruits should be served daily in organization messes. Advantage should be taken of fruits that are in season for they are of the best quality and lowest price. With the present cold storage facilities, citrus fruits are in season the entire year. They are of especial value for their vitamin content and should be included in the menu at frequent intervals. The vitamin content of fruit is utilized to best advantage when served raw, however, a variety of desserts can be made by the cooking of fresh fruits. This may be especially desirable when green apples are on the market for use in pie, cobbler, and sauces. Underripe or green fruits have a high starch content and should be cooked to make them digestible.

(2) *Vegetables.*—Fresh vegetables are best in appearance and flavor and richest in vitamin value when freshly gathered. Much of the vitamin value is lost through storage and handling, due to oxidation.

More vitamins and minerals are lost through overcooking or cooking in a large amount of water. Some of the vitamins are destroyed by heat or dissolved in water. It is obvious, therefore, that the maximum nutritive value will be retained by the avoidance of overcooking, soaking too long in water, and the use of small quantities of cooking water. The water in which the vegetables are cooked contains water-soluble vitamins and minerals and should be used for soups, gravies, and sauces. As many of the vitamins and minerals are lost through cooking, fresh vegetables should be served raw as salads when it is safe to do so. Raw carrots can be combined with raisins. Coleslaw combined with apples and a little raw onion makes a good salad rich in protective foods. However, salads should be prepared just before serving to preserve their freshness and nutritive value. Many such varieties can be made by the cook, through planning and the exercise of ingenuity.

b. Dried.—(1) *General.*—There are several terms used to designate dried fruits and vegetables: dehydrated, evaporated, sun-dried, and dried. These terms refer to the methods used for drying. “Dried” refers to all dried food regardless of the means used for extracting the moisture. Considerable progress has been made in the dehydration of fruits and when properly prepared they will make a very tasty dish. There are two classes of dehydrated fruits and vegetables on the market. The flake and powder form does not rehydrate to its original form and is used for jellies, desserts, bakery products, ice cream, ices, and sherbets. The other form is the fruit or vegetable dehydrated in the original form or in pieces, and when rehydrated, can be used the same as fresh fruits or vegetables.

(2) *Fruits.*—During an emergency it may be necessary to use dried fruits to conserve storage and transportation space. Much of the vitamin and mineral content is lost during the dehydration process but those fruits are otherwise of the same nutritional value as canned fruits. Dried fruits, such as raisins, prunes, and apricots, are subject to insect infestation and should be kept in well-ventilated storage not over 50° F. Others are dried to a very low moisture content and do not require as low a storage temperature. These products take up moisture from the air very rapidly and should be stored in a dry place and kept well covered at all times.

(3) *Vegetables.*—The terms used for dried fruits apply also for dried vegetables. The powder and flake are used for seasoning and soups. The whole or diced and sliced types are used for vegetable dishes in the same manner as fresh vegetables. Many of these prod-

ucts require but a few minutes for preparation as compared to hours with the old type of dried vegetable.

(a) *Beans*.—There are a number of types of dry beans that may be purchased for mess uses. Each type has a number of different varieties with the exception of the black-eye bean, which is also known as the “cowpea” or “black-eye pea.” The Great Northern navy bean may be issued at one time and a small pea bean the next. The two are different varieties of the navy bean. The kidney bean may be red or dark red; the lima bean may be large or baby lima bean. The eating qualities of the various varieties are the same, but the cooking qualities differ. For this reason the issue should be of one variety. These dry beans should be soaked for several hours before cooking. If large navy beans are mixed with small pea beans, the small bean will be overcooked and mush before the large bean is properly cooked. The white beans are preferred for baking while colored beans, lima beans, or black-eye beans are usually simmered.

(b) *Rice*.—Polished rice is usually supplied the Army mess. Unpolished or “brown rice” has a high vitamin content, especially B complex, and should be used where the soldier will eat it. It has a different flavor from polished rice and should be tried in the mess before a large quantity is ordered.

44. **Jams, jellies, preserves, and fruit butters.**—*a.* Jam is made from whole small fruits which are either mashed or cooked to a pulp with sugar. Good jam is soft, tender, and jellylike in texture, bright and sparkling in color, and of the same consistency throughout the mixture.

b. Jelly is made from the juice of the fruit combined with sugar. A good jelly is clear, bright, and tender. When cut, it has a clean surface and does not stick to the knife or spoon. When turned from the glass, jelly should hold its shape and should quiver but not break.

c. Preserves are whole fruits or pieces of fruit preserved in a heavy sugar sirup. A good preserved fruit is plump, tender, and bright in color.

d. Fruit butters consist of the whole fruit cooked until tender and then rubbed through a sieve to remove the seeds and skin. The pulp is added to sugar and spices and cooked until smooth and thick.

45. **Lard and lard substitute.**—*a.* Lard is rendered hog fat. Lard substitutes are made from animal and vegetable fats or from vegetable fats alone. Lard and lard substitutes containing animal fats are usually very near the same price. The nutritive value of

these fats is approximately the same in cooking and in the diet. Considerable improvements have been made in lard, giving it a high breaking point (point where it will smoke), making it more desirable for deep fat frying. Lard is also preferred for pies and biscuits.

b. Excess fat cut from fresh beef and pork should be rendered and used for frying. Drippings from roasts and bacon should also be saved and used for frying and making gravies.

46. Macaroni, noodles, and spaghetti.—These products are known as alimentary pastes. The different forms and sizes of these pastes are merely a matter of different molds in the machinery and cutting to desired size. Noodles are made from the same kind of paste as macaroni and spaghetti except that eggs are sometimes included and are thus known as egg noodles.

47. Dressings, salad.—*a.* Mayonnaise dressing is made of edible oil, egg yolk, lemon juice or vinegar, and seasoning (salt, pepper, etc.). Mayonnaise may be made in the kitchen at a considerable saving. A variety of dressings can be made using mayonnaise as a base. Russian dressing can be made by adding lemon juice, chili sauce, and Worcestershire sauce to taste. Tartare sauce can be made by adding chopped green olives and pickles to mayonnaise.

b. Salad dressing might be thought of as a diluted mayonnaise. It is made of oil, egg yolk, lemon juice or vinegar, and cornstarch as a filler. A good salad dressing should contain at least 35 percent oil. However, many brands are on the market with as low as 9 percent oil. For this reason there is a great variation in price. The same variety of dressings may be made as with mayonnaise using salad dressing as a base.

c. French dressing is a mixture of oil, lemon juice or vinegar, salt, mustard, and other spices, if desired. The oil will separate from the liquid and spices and care should be taken to see that the ingredients are well mixed before using. French dressings are now on the market containing a carrier that prevents separation.

d. The common salad oils used are refined cottonseed and corn oil. Olive oil is also used but is usually too expensive for use in the mess. Soya bean oil is used to some extent but does not have the keeping qualities of the other oils. Any of these oils may be used for making the various dressings in the troop mess.

48. Sirup.—There are many kinds of sirup. They differ in body and flavor. A sugar sirup may be made by boiling 1 pound of white sugar, 1 pound of brown sugar, and 1 pint of water. This may be flavored with maple or vanilla extract. Pure maple sirup is usually too expensive for mess use. A maple-flavored sirup is a good sub-

stitute. Molasses which is a good source of iron and calcium is used for both table and cooking.

49. **Sugar.**—*a.* Sugar is made from beets or sugarcane. There is no difference between cane and beet sugar. The term “granulated” simply means that the sugar is in crystals of a certain size. The Army uses the size “fine granulated” or “medium fine granulated.” Powdered sugar is beet or cane sugar, ground to a powder. The powdered sugar for icing contains a small percentage of starch to give the icing a smooth appearance.

b. Brown sugar has not been completely refined and contains a small amount of molasses. Therefore its mineral content is higher than that of refined sugar—this gives brown sugar its distinctive flavor. It is used where its flavor and color are desired as in some types of cookies, cakes, and puddings. If brown sugar is kept in a moist place or in a tight jar it will not cake, but if kept in a dry place it will cake.

50. **Tapioca.**—Tapioca is a starch manufactured from the cassava root. It is made in the following forms: small pearl, medium pearl, flake, and granulated. All of these have the power of swelling and becoming jellylike when cooked. Pearl tapioca is used chiefly for puddings; the flake and granulated forms are valuable as binders for juicy pies.

SECTION IV

PRACTICE OF COOKING

	Paragraph
Cooking, general.....	51
Methods of cooking and terms defined.....	52
Heat, use in cooking.....	53
Cooking in fat.....	54
Seasoning of foods.....	55
Methods of meat cookery.....	56
Meats, carving and serving.....	57
Poultry, methods of cooking.....	58
Fish cookery.....	59
Vegetable cookery.....	60
Soups.....	61
Gravy.....	62
Salads.....	63
Baking.....	64
Beverages.....	65

51. **Cooking, general.**—*a.* When cooking was first discovered, the primary object was to make food more appetizing than when in the raw state. Proper cooking, in addition to making food more appetizing and easier to chew, makes some foods more digestible, and also

destroys any disease germs or parasites which may be present in the food. It is now known that cooking must take into consideration the possibilities of the loss of nutritive value, particularly the vitamins and minerals, if the soldier is to be well fed.

b. Skillful cooking is an art, acquired by experience and training. The experienced and skillful cook does more than apply heat to food—he knows how to combine and blend foods so that appetizing flavors are developed; how to season for the same result; and how to get the most out of the food supplies on hand.

c. Although it requires experience and training to become an expert cook, anyone, after having learned the fundamentals of cooking, can cook a satisfactory and appetizing meal by following the recipes given in chapter 2. These fundamentals of cooking are simple but all-important. Two of them which should be carefully observed are use of the proper temperatures and proper cooking times for different foods. All foods cannot be cooked at the same temperature and for the same length of time. Meats require long cooking at moderate temperatures; green vegetables should be given a short cooking; pastry is baked for a short time at comparatively high temperature. From the foregoing it will be seen how important it is to learn the fundamentals of cooking before starting to cook.

d. The term “cooking” is often used to mean the preparation of food for cooking as well as the actual cooking. This preparation may be merely peeling, as in the case of onions, potatoes, etc., or it may include cutting, slicing, grinding, chopping, etc. While preparation changes the form of food, the actual cooking may not only change the form but may also change the flavor or chemical composition, thus rendering the food more appetizing and digestible. An example of this is the cooking of potatoes and other starchy foods. Starch, when raw, is difficult to digest; when changed by cooking it is easy to digest. On the other hand, improper cooking decreases palatability and results in waste, loss of nutritive value, and may mean an inadequately fed soldier.

52. Methods of cooking and terms defined.—*a. Methods.*

Baking.—Cooking by dry heat, usually in an oven.

Boiling.—Cooking in water at a temperature of 212° F. Slowly boiling water has the same temperature as rapidly boiling water, consequently is able to do the same work—a fact often forgotten by the cook, who is apt to wood the fire that water may boil vigorously.

Braising.—To brown in a hot receptacle in a small amount of fat, then cook slowly in a small amount of liquid, covered.

Broiling.—Cooking by direct heat from hot coals, a gas flame, or an electric element.

Deep-fat frying.—Cooking in hot fat at a temperature of from 350° to 400° F., depending on the nature of the food to be cooked.

Fricasseeing.—A combination of sautéing with stewing. The food to be fricasseed is first sautéed, then stewed.

Frying.—Cooking in just enough fat to keep the food from sticking.

Oven broiling.—Cooking in a broiler pan that runs close under the heat in the broiling oven of a gas or electric stove.

Pan broiling.—Cooking in a hot griddle or pan greased only enough to prevent food from sticking.

Pressure cooking.—Cooking in steam at a pressure of 5 to 30 pounds and at temperatures 228° to 274° F. The rise in the temperature of the steam is caused by holding it under pressure. A special cooker is necessary for this cooking.

Roasting.—As now used, this means the same as baking. The term is usually applied to meat cookery.

Sautéing.—Cooking in a small quantity of fat. The article to be cooked must be shifted from side to side and turned to come in contact with the fat.

Searing.—Browning the surface of meat by the short application of intense heat.

Simmering.—Cooking in water at a temperature of 180° to 210° F., or below the boiling point of water.

Steaming.—Cooking in the steam generated by boiling water.

Stewing.—Cooking in a small amount of water. The water may simmer or boil, as indicated for the food that is to be cooked.

b. Cooking terms.

Baste.—To pour liquid over a piece of meat during roasting or broiling to prevent drying. The liquid used may be pan drippings, water, stock, milk, or melted butter.

Bouillon.—A soup stock made from lean beef, clarified by straining, and seasoned. It may be used as soup stock or served as soup.

Broth.—The liquid resulting from simmering meat in water.

Consomme.—A soup made from two or more kinds of meat, then seasoned, strained, and served clear.

Drawn butter.—Melted butter, flour, seasoning, and hot water used as a sauce for fish and vegetables.

Lard.—Placing strips of fat on top of, or inserting into, meat to add flavor and prevent dryness in roasting.

Lardoon.—A long, slender, pencil-like portion of salt pork, bacon, or suet, used for larding.

Marinate.—To let stand in a mixture such as oil, vinegar, lemon juice, and seasoning called a marinade.

Parboil.—To boil until partly cooked.

Pot roast.—A piece of meat cooked by braising. Usually the less tender meat cuts are prepared as pot roasts.

Stock.—The liquid obtained by simmering meat and bones. A good base for soup and gravies.

53. Heat, use in cooking.—*a. General.*—While all the general operations of the kitchen are called “cooking,” the term applies particularly to the application of heat to the food. This heat creates new flavors in the food and generally improves its edible properties and digestibility. Heat, assisted by moisture, swells and bursts the starch cells in flour, rice, and potatoes; hardens the proteins of eggs, fish, and meats; and softens the fibrous substances in meats, vegetables, and fruits. The quantity of heat depends upon the required temperature and the time of cooking as well as the size, density, and other properties of the food to be cooked.

b. Temperatures and times of cooking.—(1) Tables showing temperatures and times of cooking for different foods are given in the appendix. On examining the table of temperatures, it will be noted that they vary greatly for different foods. Best results will be obtained by using the temperature indicated for each food. Further, this temperature must be uniformly maintained during the entire cooking period. It must be remembered that it requires time for the heat to penetrate to the center of the article being cooked. If the temperature is allowed to rise suddenly, the outside may become scorched or burned before the center is cooked.

(2) The proper temperatures and times for cooking are also shown in the recipes for various foods and dishes given in Chapter 2. However, a study of the table and observation of a few rules will greatly assist the cook in understanding this important feature of cooking. A knowledge of these general rules will insure good cooking even when recipes are not available. These general rules are given below:

(a) *In oven.*

1. *Starchy foods.*—Starchy foods (breads, pies, potatoes, squash, macaroni, etc.) are cooked at high temperature for a short time. A quick oven (400° to 450° F.) is used and the time of cooking is not over 1 hour.

2. *Sweet dough products.*—Sweet dough products (cinnamon buns, coffee cake, etc.) and cakes, pastries, cookies, etc., are baked in a medium oven (325° to 400° F.). These products contain a high percentage of sugar and, because sugar will caramelize (turn brown or black) easily in great heat, these foods will scorch or burn on the outside before the inside

is cooked if they are cooked in heat greater than 400° F. The time of cooking is not over 1 hour and usually less than 30 minutes.

3. *Protein foods*.—Protein foods (meats, beans, etc.) are roasted or baked for a longer time than starchy foods, but the temperature is lower. Meats are roasted in a moderate oven (250° to 325° F.) or at simmering temperature (180° to 210° F.). Meats can be cooked at high temperatures (and sometimes are so cooked by careless or inexperienced cooks), but this impairs palatability and increases cooking losses and nutritive value. Beans should be baked in a slow oven as a high temperature toughens the skins.

(b) *Frying*.—All foods are fried at a relatively high temperature. This is a necessity so that the hot fat will quickly seal the surface and prevent grease penetration. In order to insure that the center will be cooked before the outside has had time to become scorched, fried foods are cut in relatively thin or small pieces. In other words, a thick piece of meat or other food cannot be fried successfully if it is to be well done. For these reasons (high temperatures and thin pieces of food) frying is a quick method of cooking.

(c) *Cooking in water*.

1. *Vegetables*.—Vegetables, when cooked in water, are cooked at boiling temperature, with the exception of dry beans which are simmered. Vegetables are boiled only long enough to make them tender. They should never be cooked longer than this. A maximum of 15 minutes is required for the leafy vegetables (as cabbage, spinach, etc.) and between 30 and 45 minutes for the starchy and root vegetables (as potatoes, carrots, onions, turnips, etc.). During cooking some of the nutritive value of food is dissolved in the water. If this liquid is not served with the food it should be used for soups, gravies, stews, or sauces.

2. *Beans, rice, and paste products*.—Dry soaked beans, peas, or lentils are brought to a boil in the water in which they are soaked, and simmered over low heat until tender. They require a longer period of time than other vegetables. Rice is cooked in enough boiling water to cover until tender. It must be stirred frequently. Macaroni, spaghetti, and noodles are boiled in large amounts of water for a short period or until tender. Overcooking causes a mushy, sticky product.

3. *Meats.*—Meats should never be boiled. They should be simmered. This requires a longer cooking time than vegetables.

c. Food particles to be of uniform size.—As explained in *b* (1) above, it requires time for heat to penetrate to the center of food. Therefore, a thick article of food, as a roast of beef, requires longer than a thin article as a pork chop. If a roasting pan is filled with pieces of beef, some weighing 2 pounds and others weighing 8 pounds, the smaller pieces will be cooked first. Unless these smaller pieces are removed from the oven they will become overcooked before the larger pieces are cooked. Therefore, an effort should be made to cut the pieces in uniform size. This also applies to potatoes and many other foods.

54. *Cooking in fat.*—*a. General.*—Cooking in fat is done either in shallow fat (just sufficient to form a film between the food and the hot pan) or in deep fat (sufficient melted hot fat to cover the food). Cooking in shallow fat is called sautéing by some chefs, and some cookbooks call it pan frying; however, the term commonly used in the United States is simply frying and foods so cooked are called fried. Foods cooked in deep fat also are called fried except that potatoes so cooked are called french fried. In this manual, when it is desired to indicate that a food should be cooked in shallow fat it will be called fried (example—potatoes, fried), and when it is desired to indicate that a food should be cooked in deep fat, this manual will use the expression, “fry in deep fat.”

b. Advantages.—Cooking in fat has the following advantages:

- (1) It is a quick method of cooking.
- (2) It gives a distinctive and pleasing flavor.
- (3) Part of the fat is absorbed by the food, thus increasing nutritive value.

c. Fried foods not to be served too often.—Fried foods should not be served too often as men quickly tire of them; they are unhealthful as a steady diet because of too much fat in the food and also because fat is digested less easily than other foods.

d. Frying in deep fat compared with frying in shallow fat.—(1) Frying in deep fat has advantages over frying in shallow fat. One is that the flavor is better; another, that less time is required. The chief advantage is that the food is entirely surrounded by hot fat and therefore is cooked so quickly that there is not time for fat absorption.

- (2) In shallow fat the food is not entirely surrounded by hot fat

and is not cooked as quickly as in deep fat. Therefore, foods fried in shallow fat usually absorb more fat than if fried in deep fat.

(3) In deep fat the food does not come into contact with the pan. In shallow fat the food is in contact with the hot pan and it frequently becomes necessary to move the pan off the fire or reduce the temperature to prevent scorching. Therefore, frying in shallow fat should be done at a lower temperature than in deep fat. On account of this lower temperature it requires longer for the formation of a crust on the outside of the food and longer to cook. Only sufficient fat should be used to prevent burning in order to avoid grease-soaked food.

e. Frying in deep fat, procedure.—(1) *Proper temperature of fat.*—The fat must be hot so that the food is cooked quickly and a crust is quickly formed on the outside. However, the fat must not be heated until it smokes. Too hot a fat will scorch the outside of the food and leave the center raw. Too low a temperature will grease-soak the food being prepared. An experienced cook easily recognizes this temperature. A good practical test is to drop into the hot fat an inch cube of bread from the soft part of the loaf. The bread will be golden brown in 60 seconds at the proper temperature for frying. If the cook is not certain that the fat has been heated to the proper temperature, he should test it with a thermometer. Lard substitute and vegetable shortening begin to smoke at about 450° F. Pure lard begins to smoke at about 380° F. Frying temperature should be between 350° and 375° F. The larger pieces of food should be fried at the lower temperature to completely cook the food.

(2) *Frying moist foods.*—Care should be used in deep-fat frying of foods which have a moist surface as the moisture may form steam when it comes into contact with the hot fat, and this steam may cause the fat to boil over and catch fire, or to pop out on the cook. For example, potatoes prepared for french frying, which have been immersed in water, should be drained before being put into hot fat.

(3) *Avoid cooling fat.*—Unless the fat is kept hot, it will not cook the food quickly and will not quickly form a crust on the outside. This will allow the fat to soak into the food. A common error is to introduce too much food at one time (as in the frying of doughnuts), thus cooling the fat. Another common error is to cool the fat by introduction of foods which are cold on account of having been frozen or kept in a refrigerator. Such foods should be kept in a warm room sufficiently long to lose the chill before being fried.

(4) *Drain foods after frying.*—Foods fried in deep fat should be

drained after frying. This may be done in a colander, wire basket, sieve, or by laying on paper. Ordinary brown wrapping paper will do.

(5) *Fat clarifying.*—The question often arises whether fat which has been used for deep frying can be used again. To a great extent this depends on whether the fat has been heated to the smoking point, and whether any foods have been allowed to scorch or burn in it. In either case the fat will impart a disagreeable odor and taste to foods subsequently fried in it. It should be clarified. One method of clarifying used fat is to strain it by pouring the warm melted fat through a cloth. Two thicknesses of clean flour sack will suffice. This removes burned particles of food, but may not entirely remove the disagreeable odor and taste. Additional clarification may be accomplished by allowing the fat to cool until it hardens; then melt it, add a few raw potatoes cut into quarter-inch slices, and heat gradually. When the potatoes are well browned and no bubbles appear on the surface, the fat should be strained. The potatoes absorb the odors and most of the sediment and should be discarded as they will be grease-soaked.

55. Seasoning of foods.—*a.* All foods placed on the mess table should be seasoned so as to have a pleasing flavor. The quantities of seasoning given in recipes are only a guide; the expert cook seasons to taste. Because of the varying amounts of moisture, fat, sugar, etc., in foods, it is difficult to prescribe exact quantities of spices and other seasonings. Sometimes the cook falls into the error of assuming that because he has added pepper and salt the flavor is satisfactory. The only way to determine this is to taste the food. Always use a *clean* spoon for testing. It is well to remember that seasoning, once in the food, cannot be removed. It is better to use too little than too much.

b. Left-over foods have usually been previously seasoned and great care must be used in adding seasoning, especially salt, when preparing them for subsequent meals.

c. The full strength of most spices, as sages, marjoram, cloves, etc., is not immediately noticeable in the food to which added, but increases as the food is cooked. The heat and moisture gradually bring out the full strength.

d. Garlic is used to advantage in seasoning meats, gravies, sauces, soups, salads, and salad dressings, but must be used with judgment, as many men do not care for any flavor of garlic, and to most persons a pronounced garlic flavor is objectionable. Garlic flavor, when present, should be delicate, which may be obtained by rubbing the

inside of the cooking utensil or salad bowl with a cut clove of garlic, or the meat may be rubbed. A delicate flavor of garlic makes all meats, especially roasts, more savory and appetizing, and gives a tang to soups, stews, salad dressings, etc., which is very appealing.

e. As a general rule, food should be seasoned during the process of cooking. Added flavoring and seasoning at the table cannot make up for lack of proper flavoring and seasoning while cooking. Vegetables should be cooked in salted water and more seasoning added before serving, if necessary. Roasts and steaks may be seasoned during cooking or at time of serving. Pot roasts and stews should be seasoned during cooking. Dishes prepared from ground meats should be seasoned when prepared for cooking.

56. Methods of meat cookery.—*a. General.*—The method used in cooking meat depends on the cut. The tender cuts have a small amount of connective tissue and are cooked by dry heat: roasting, broiling, and pan broiling. The less tender cuts with considerable connective tissue must be cooked by moist heat because dry heat toughens the connective tissue, while moist heat softens it. Methods of cooking by moist heat are: braising, cooking in water (simmering), and stewing (small pieces simmered).

b. Roasting.—The time required to roast meats depends upon the temperature of the oven, the size and shape of the piece of meat, and the amount of fat. Well-done meat requires a longer time to cook than rare meat; a large piece of meat requires longer to cook than a small piece, but less time per pound; fat meats tend to roast more rapidly than lean meats. Meat can be cooked well-done at any reasonable oven temperature, although the best results are obtained with a moderate oven temperature (about 300° F.) because the meat is cooked more evenly than in a hot oven. Furthermore, there are less cooking losses, more juice, more servings, and the meat is more palatable. It is not necessary to sear meat before cooking, except to develop flavor on the outer surface. Browning of the meat juices in the pan after the meat is done will develop flavor for gravies. The gravy of roasted meats plays an important part in a satisfying meal. A good gravy is as important as well-roasted meat.

(1) *Beef.*—Wipe the roast with a damp cloth. (Meat should never be washed or soaked in water.) Place meat in a pan with fat side up. Roast at 300° to 350° F. For meat well-done, allow 50 to 60 minutes per pound for rolled roasts, and 40 to 50 minutes for unboned roasts.

(2) *Veal.*—Wipe the meat with a damp cloth. Place in roaster

with the outside of the roast up and place string of salt pork or bacon over the top. Place in an oven heated to 375° F. for black pans, or 375° to 400° F. for aluminum pans, when covered. Allow approximately 30 to 35 minutes per pound. As veal contains considerable amounts of connective tissue, it requires a moist heat and should be cooked in a covered pan.

(3) *Pork*.—Place the roast in the pan with the fat side up. For fresh pork, place in an oven at 325° to 350° F. and cook until done—from 30 to 35 minutes per pound. Cured pork is cooked at a slightly lower temperature (250° F.) and usually requires from 25 to 35 minutes per pound.

(4) *Lamb*.—Same as for roast beef.

c. Pan broiling.—The cuts which lend themselves best to pan broiling are tender beefsteaks, lamb or mutton chops or steaks, ham, and bacon. The broiling should be done on a hot plate or frying pan, uncovered, pouring off fat as it accumulates in the pan. Sear the meat quickly on both sides, and then cook more slowly until the desired degree of doneness is reached. Bacon is put into a cold pan, cooked slowly and the fat poured off frequently.

d. Braising.—Meat for braising should be cut quite thin. A little fat is melted in a hot frying pan. The meat is browned quickly on both sides and then cooking continued at a lower temperature in a covered pan. The cuts of meat usually cooked by braising are round steaks, veal steaks or chops, and pork chops.

e. Pot roast of beef.—Cuts of beef suitable for a pot roast are chuck, ribs, clod, round, and rump. Rub the roast with salt, pepper, and flour. Brown the meat on all sides in a small amount of melted beef fat. After searing, add a small amount of water, cover tightly, and simmer until tender. Time required: about 3 hours.

f. Stewing.—A stew is a dish made from small pieces of meat. This is an excellent way to utilize trimmings and less tender cuts of meat. The vegetables are added to stews at the time and in the order required to cook them satisfactorily with the least loss of nutritive value. There are three methods for making stews:

(1) The meat may be browned before the water is added. This gives the meat a "roast" flavor and the gravy a rich color.

(2) The meat may be plunged into boiling water. This will not have the rich flavor of the browned meat but the vegetables cooked with the stew will have more of the meat flavor.

(3) The meat may be placed into cold water and brought to a simmer. The broth in which the meat is cooked will have a rich flavor and the meat eaten by itself will be somewhat tasteless.

57. Meats, carving and serving.—*a. General.*—(1) The chief objectives of good carving are to obtain attractiveness and the best flavor from the meat, and to prevent waste. Meat should never be carved with a hard, sawing motion. Carved meat should be placed on the platter with the most appetizing side up and the pieces arranged in an attractive manner, not thrown loosely on the platter. It requires no expense, and very little effort, to arrange meat neatly on a platter so that it will be pleasing to the eye.

(2) Good carving cannot be accomplished without good tools. Sharp carving knives are essential. Knives should be run over a steel just before starting to carve and frequently during the carving, if the amount of carving warrants. (See fig. 1.) The steel should be held in the left hand, in a nearly horizontal position (the point slightly raised) and parallel to the body. The knife should be held in the right hand. Start the blade along one side of the steel, beginning with the heel of the knife at the point of the steel. The strokes should be reversed from side to side of the steel. All hand motion of the knife blade along the steel should be in the wrist and not a movement of the entire forearm. The touch of the blade on the steel should be light and six strokes should be sufficient; if more are required, the knife should be sharpened on a stone. If the knife is sharp the cut will be clean and even.

b. Carving rib roasts.—Beef should be sliced across the grain into pieces of uniform size and thickness convenient for individual service, not cut into chunks. Rib roasts are tempting and appetizing when neatly sliced across but have no appeal if cut into chunks. An excellent way of carving a rib roast is as follows: Stand the roast on end on a carving board or wooden table with the rib bones to the left of, and with the meat side away from, a right-handed carver. Stick a large meat fork in the bone side of the roast, low enough that the knife will not strike the fork, and hold the roast firm with the fork in the left hand; cut thin slices across the grain until the knife reaches the bone. Cut several slices in this manner, leaving them attached to the bone and then run the point of the knife along the bone, releasing the slices. By this method all the meat can be cut from the bones except the small strings between the ribs.

c. Carving round roasts.—Use a long, thin knife. To start the carving, place the roast on a carving board with the large or rump end down and the small or shank end up. Start at the outer edge of the meat and cut across the face (across the grain) of the roast, cutting toward the round bone and making the slices about $\frac{1}{8}$ inch

thick. As the knife approaches the bone, raise the edge so that it will come to the surface just as it reaches the bone. Each slice should be about the size of the hand. Continue slicing around the roast, turning it so as to keep the cut surface of the roast level.

d. Preparation and carving of pork loin roasts.—Pork loins contain the backbone and part of the rib. The backbone should be cracked with a cleaver at about 1-inch intervals before roasting the meat. This enables the carver to cut slices from the loin through the meat and the bone. The slices should be about $\frac{1}{4}$ inch thick and every other slice will contain a piece of the backbone and the rib.

58. Poultry, methods of cooking.—*a. Roasting.*—Young cockerels weighing from $3\frac{5}{8}$ to 5 pounds and over, and turkeys, ducks, and geese, are used for roasting. The whole drawn bird is usually roasted and stuffed with any desired stuffing. Brush the skin of the bird with melted or softened fat. Place in a slow oven (250° F.), breast up, in an uncovered pan. Place strips of body fat removed in dressing over the breastbone. Bacon or salt pork strips may be used. Allow 25 to 30 minutes per pound.

b. Broiling.—Only young, tender chickens should be used for broiling. As the birds are small they are cut in half and placed on the broiler rack, rib side up. Cook until tender and brown, turning frequently. The fire should not be too hot or the outside will brown and the inside remain raw. Cooking time about 20 minutes.

c. Frying.—For frying, the chicken is cut into four to six pieces. Roll each piece in flour or other mixture and sauté in a little fat until brown and tender. If the chicken is not young, it is advisable to parboil or steam it before frying.

d. Stewing or fricassée.—Cut up the chicken as for frying. Brown in a pan with fat, cover with boiling water, season, and *simmer* until tender. The liquid is then thickened with cornstarch or flour before serving.

59. Fish cookery.—*a.* Fish are a healthful and delicious food, if properly prepared. Salt water fish are an important source of bromine and iodine. In all fish the protein or tissue-building material is excellent.

b. Fish may be divided as follows:

(1) *White fish.*—Fish that have less than 5 percent fat, examples of which are smelt, flounder, yellow perch, pike, pickerel, cod, and haddock.

(2) *Fat or oily fish.*—Fish that contain 5 percent or more of fat, examples of which are salmon, herring, lake trout, mackerel, and eels.

(3) *Shellfish.*—Oysters, clams, scallops, lobsters, crabs, shrimps, and prawns.

c. Fresh fish, or fish that were frozen while fresh, have full or bulging eyes, bright red gills, firm and elastic flesh, and fresh odor. Be sure the flesh along the backbone smells fresh; it spoils there first. Fresh fish sink in fresh water. If they float, they should not be used. Frozen fish need not be thawed before cooking. In case the fish have not been cleaned, they should be thawed only sufficiently to permit cleaning and then cooked. Frozen fish that come cleaned should be cooked without thawing, allowing slightly more than the usual time for cooking.

d. To fresh salt fish, place the flesh side down in a pan of fresh water, and let soak from 1 to 48 hours, changing water several times. If the fish are to be cooked in liquid, they will need a shorter time in soak than if they are to be cooked with very little moisture.

e. Fish must be well cooked to be palatable and wholesome. They are cooked sufficiently when the flesh separates easily from the bones. If underdone, they are not eatable; if cooked too long, they are dry and lose most of their flavor. All of the various methods of cooking may be applied to fish. The principal thing is to be sure that the fish are well cooked and still not overcooked. Frying and deep-fat frying are the most popular methods of preparing fish in the Army. The fat for deep-fat frying should be maintained at 360° F. For large pieces the fat should be slightly lower temperature.

60. Vegetable cookery.—*a. General.*—The method of cooking vegetables will usually have a decided effect, either good or bad, upon their color, odor, flavor, or nutritive value. In some vegetables one method of cooking will preserve all these qualities, in others it may be necessary to sacrifice one or two to preserve the third, but it is never necessary to sacrifice all four as is frequently the case. In general, vegetables should be cooked as short a time as possible.

b. Preservation of color.—Vegetables naturally fall into four groups of color: green, yellow, red, and creamy white.

(1) Chlorophyll, the coloring pigment of green vegetables, is easily destroyed by heat and acid. When green vegetables are cooked for a long time in a small amount of water or steam in a covered vessel or under pressure, the chlorophyll is decomposed. Vegetables which can be quickly cooked, such as spinach or mustard greens, will retain their green color if not overcooked, but other items which require 20 to 30 minutes to cook will lose a considerable amount of their green color. The general rule for the preservation of green color is to drop them into boiling water and cook them uncovered for the shortest possible time.

(2) Yellow color found in carrots, squash, and sweet potatoes comes

from a class of pigments called "carotinoids" which is always associated with the chlorophyll in green vegetables, but remains invisible until the latter is dissipated. This yellow color is largely due to carotene which the body transforms into vitamin A. It is relatively stable to heat but is destroyed by oxidation. It is necessary to consider these facts when cooking yellow vegetables. When green vegetables are overcooked the chlorophyll is dissipated, and the little which remains, together with the yellow pigment, gives the item a greenish bronze appearance. The yellow pigment is very stable and vegetables which have only this color can be cooked in any method without affecting any color change, but overcooking will tend to destroy carotene. When yellow vegetables turn dark brown it is usually the result of oxidation (improper care after preparation for cooking, and overcooking) or a scorching or caramelization of the sugar content.

(3) Red color is rather rare, being found in beets, tomatoes, red cabbages, and radishes. This color will remain red in the presence of acid but turns to violet or purple when cooked in an alkaline water. To preserve the red color when cooking red vegetables a little vinegar or lemon juice should be added to the water. Tomatoes and unpeeled beets can be cooked without added vinegar and retain their color because they have sufficient acid content. The acid also tends to retard the destruction of ascorbic acid.

(4) White vegetables are fairly stable in heat. White vegetables will turn a grayish color when a long time is consumed in the cooking. Discoloration can be avoided by the simple expedient of a "short cook," that is, only enough to make the vegetable tender.

c. Preservation of flavor.—So far as cooking for retention of flavor is concerned, vegetables divide themselves into three classes: the cabbage family, which includes brussels sprouts, cauliflower, and turnips; the onion family, including garlic, shallots, and chives; all other vegetables.

(1) The vegetables of the cabbage family contain sulfur compounds which break up easily under the application of heat and produce products which are disagreeable to the sense of taste and smell. One of these substances is hydrogen sulfide, the same gas which causes rotten eggs to have such an offensive odor. Decomposition of the sulfur compound is brought about by long cooking or by cooking at low temperatures, which should be avoided. Vegetables of the cabbage family should never be cooked in a pressure cooker as all of the volatile acids evolved from the vegetables are retained. Such vegetables should be cooked in the shortest possible time in an uncovered vessel and in a large amount of water.

(2) The onion family is really the "strong-juiced" group. They obtain their strength from certain volatile and aromatic substances formed in the growing stage. They do not behave like the cabbage family in cooking, for they do not form new odors or flavors but simply loose part of those present. When heat is applied, the volatile substances begin to dissipate with the steam. The properties which provide a pleasing flavor do not always provide a pleasing odor. With long cooking, the flavor is entirely volatilized and the resultant product is insipid and flat in flavor. Thus the flavor of these vegetables is controlled through the length of time they are cooked.

(3) All other vegetables lose flavor when cooked in a large amount of water and the method best suited for their preparation is to cook them in the least possible amount of water, or in a steamer or pressure cooker.

d. Preservation of nutrients.—The inherent nutritive value of foods may be affected by storage, preparation, cooking, and service. It is necessary to give preference to those procedures which will retain the maximum nutritive value. In general, foods should be stored in a cool place; prepared with a minimum of handling, soaking, or removal of parts; and cooked the shortest time and at the lowest temperatures compatible with palatability. Food should be served as soon as possible after it is done. The three principally employed methods of cooking vegetables are baking, steaming, and boiling. These will be considered solely from the standpoint of nutrient savings.

(1) Baking means cooking in dry heat in an oven, with the addition of little or no water. This is a good method of cooking as nutritive losses are small, the chief loss being vitamin C. There will be some loss of B₁, depending upon the temperature, length of time the product is baked, and if the skins are left intact.

(2) The next best method is steaming. This can be done either in a vessel where the temperature never exceeds that of boiling or in a pressure cooker where 249° F. can be attained. The cooking is accomplished without the addition of water to the vegetables except a small quantity necessary for the steam. The special advantage of this method lies in the fact that the only water which comes in contact with the vegetables is the minute quantity which is formed by condensation of the steam.

(3) More nutrients are lost by boiling vegetables than by any other method of cooking. The loss is in direct proportion to the time of cooking and the exposed surface of the vegetables. When vegetables are exposed to the solvent action of water, the smaller the pieces into which they are cut, the greater will be the loss of nutrients. Some part

of the minerals and other nutrients which have escaped into the boiling water can be recaptured by using the water in which the vegetables are boiled for soup, and this should be done as far as possible.

61. Soups.—*a. General.*—When beef is issued in carcass form the bones should not be discarded; they should be used for soup stock. An inspector never finds a raw bone in the garbage can of a well-conducted mess. Soups can be made the means of preventing waste by incorporating in them food which might otherwise be wasted, such as all raw beef bones, excess liquid from canned vegetables, left-over cooked vegetables, and vegetable scraps (celery, onion, and beet tops, lettuce, and cabbage trimmings). If meat is used in soup, it should be cut into small cubes, as this aids in dissolving the meat juices into the soup by exposing more surface to the heat.

b. Soup stock.—A pot for soup stock should be found in every Army kitchen. To make soup stock, crack the bones and cut the meat into small pieces. Put bones and meat in a large container with a close-fitting cover and add 1 quart of water for each pound of meat and bones. Heat slowly to the simmering point and add salt; simmer for 4 to 5 hours, then cool. Fat will form on the top after cooling and should not be taken off until the time to use the stock, as this layer of fat acts as a preservative by excluding the air. In warm weather soup stock may sour if kept for more than 24 hours. If necessary to keep longer than 24 hours, the stock should be sterilized by being brought to a boil at intervals of 24 hours or less. Stock can be used as the base for either gravies or soups and to enrich many dishes, such as hash, meat loaf, and sauces.

c. Value as food.—Soups may provide appreciable amounts of minerals and sometimes vitamins. Thick or cream soups also provide appreciable amounts of energy. Soups have an important place in the menu. In addition to their food value, they stimulate the flow of digestive juices and thus aid digestion. Soup should always be served very hot.

d. How made.—(1) Most soups are made by first making a stock. This stock is the base of the soup. It gives strength and flavor. Before making the soup the stock is allowed to cool. This results in the fat rising to the top and hardening so that it can be removed easily. It should be removed to prevent the soup being greasy. To the stock the cook adds mixed vegetables if a vegetable soup is desired, or beans if bean soup is desired, etc. Each soup should be well seasoned with salt, pepper, and other spices such as bay leaves or marjoram. Meat may be added to many soups, if desired.

(2) Some soups are made without stock. These are usually cream

soups (cream of cabbage, cream of celery, etc.) However, a stock may be used as the base of cream soups if desired, for the added flavor and nutritive value it gives.

e. Kinds.—(1) *Thin soups.*—Thin soups like bouillon and consommé are not often served in Army messes as most soldiers prefer a thick soup; however, bouillon or consommé, if served occasionally, is acceptable and gives variety.

(a) *Bouillon.*—A soup stock made from lean beef, clarified and seasoned.

(b) *Consommé.*—A soup made from two or more kinds of meat, clarified and served either hot or cold.

(2) *Cream soups.*—Cream soups are made by boiling vegetables (as cabbage, celery, tomatoes, etc.) in water or stock, with seasoning, until the vegetables are tender, then thickening with a batter made from flour and fat and adding milk just before serving. Use of an acid vegetable (as tomatoes) sometimes causes the milk to curdle. This can be prevented by adding a pinch of soda (or about 1 teaspoonful for 100 men). If too much soda is added, the soup will have a disagreeable soda taste. Cream soups include cream of asparagus, cabbage, celery, and tomato.

(3) *Purées.*—Purées are made from vegetables (or fish) which are cooked in stock until very tender and then forced through a colander or sieve to make a mush, which is then put back into the stock. A batter of flour and fat is added to thicken the soup, which is then allowed to simmer about 1 hour before serving. Milk may be added if desired. Purées include purée of beans, carrots, green peas, lima beans, potato, tomato, etc.

(4) *Oyster stew.*—Oyster stew (sometimes called oyster soup) is made by adding flour to the liquor drained from the oysters, to make a thin batter, which is added to the soup stock for thickening and flavor. The oysters are added just before serving. The stew is then seasoned and boiled for 5 minutes. Milk may be used if desired, and improves the flavor.

(5) *Chowders.*—Chowders are soups usually made from fish or clams, although corn or potatoes are occasionally used instead. Vegetables and diced bacon are usually added. The vegetables and bacon may be boiled in stock with the fish or clams, etc., until tender; or when onions and bacon are included, they may be browned in a frying pan before being added. Chowders are usually thickened with a batter of flour and melted fat. Milk is often added just before serving. Chowders should be well seasoned. They include clam, codfish (or other fish), corn, and potato chowders.

(6) *Meat soups*.—Meat soups are made by simmering meats (usually beef) or poultry (usually chicken) until tender, then dicing the meat and adding to stock. Usually rice is added.

62. Gravy.—Gravy is the fat and juices that drip from meat while being cooked. When the clear drippings are served without the addition of other ingredients it is known as "natural gravy" and is usually served with the meat. For a brown gravy, flour is added to the drippings and fried until brown. Then meat stock, water, or milk, is added, a little at a time, and stirred continuously until the desired thickness of gravy is had. The quantity of flour and liquid added to the drippings regulates the amount of gravy and its consistency. Greasy gravy can be avoided by using only the amount of drippings necessary and the use of sufficient flour to absorb all the drippings before adding the liquids. When the quantity of drippings is insufficient, additional fat may be added to the drippings.

63. Salads.—*a.* Fruits, nuts, uncooked and cooked vegetables, cooked meats, fish and fowl, served cold and dressed with condiments, oils, and acids, are known as salads.

b. The following fundamentals must be observed in the preparation of salads:

(1) *Washing ingredients*.—Wash salad greens and examine to insure the removal of all insects. Then soak in cold water to crisp, and dry by shaking in a wire basket.

(2) *Chilling*.—All ingredients, fruits, vegetables, and dressing should be chilled before mixing.

(3) *Cutting up materials*.—Salad materials should be cut in uniform pieces small enough so that they will not lose their shape when mixed. When meat is used it should be diced and not ground.

(4) *Mixing*.—When mixing the materials they should be lightly tossed with two forks or the hands. The salad dressing should never be added to the salad until time for serving, except in the case of potato salad, when it is preferable for the dressing to soak in. The dressing should be folded in. Excess dressing should be avoided; only sufficient added to coat the separate pieces of material. Free dressing in the bottom of the dish is an indication that too much dressing was added.

(5) *Garnishing*.—The salad should be attractively served. If individual salads are served, the plate should be garnished with lettuce, parsley, green pepper, or similar small greens. Other garnishes that may be used are strips of pimento, dash of paprika, shredded carrots, whole radishes, cherries, or grapes.

64. Baking.—*a. General.*—(1) Every cook should have a good working knowledge of baking to supplement the bakery goods supplied by the post bakery. Breads are divided into two general classes: fermented and unfermented.

(a) Fermented bread is leavened by the gas formed by yeast. The yeast also acts upon the gluten and starch, making them more digestible, and gives a distinctive flavor not present in unleavened bread. There are two principal types of yeast bread: plain dough used in baking bread; and sweet dough, which contains more sugar, shortening, and eggs, and is used for rolls, cinnamon rolls, and coffee cakes.

(b) Unfermented breads are made without yeast, generally being leavened with baking powder. These products include biscuits, muffins, pancakes, corn bread, and waffles.

(2) Good baked products can be obtained only through the use of good ingredients and the exact weights and measures given in the formula. In cooking you taste and adjust ingredients as you prepare and cook the food. In baking this cannot be done, so you must follow instructions and formulas implicitly.

b. Ingredients.—(1) *Flour.*—Flour is the chief ingredient of baked goods. There are three types of white flour to consider for baking. Hard wheat (also classified as spring wheat) flours are best for bread making. This is because the gluten of hard wheat flour possesses properties of toughness and elasticity which enable the dough to stretch and hold gases produced in it by the action of yeast. Soft flours are usually milled from winter wheat, which is generally poor in gluten but rich in starch, and generally used for the baking of pastry and cakes. "All purpose flour" is a blend of flours that is higher in gluten than the hard-wheat flours. This flour is used for sweet doughs. This flour will also give satisfactory results for pastry and cakes. Bread flour will also give a satisfactory cake if a richer formula is used, that is, more shortening, sugar, and eggs.

(2) *Yeast.*—The most satisfactory temperature for the growth of yeast is from 75° to 90° F. It ceases to grow when the temperature is below 30° F. and is killed at about 200° F. Three types of yeast are in general use for bread making:

(a) In compressed yeast the yeast plants are alive and ready for action. It is very perishable and must be kept under refrigeration until it is to be used. When old, compressed yeast becomes slightly slippery and has an unpleasant odor.

(b) Dehydrated yeast is in granular form and is handled in the same manner as compressed yeast. It has better keeping qualities than compressed yeast. This yeast will keep its leavening qualities

for several weeks after removal from the refrigerator and for that reason is a good yeast for use where daily delivery of compressed yeast cannot be made.

(c) Dry yeast is a mass of yeast plants dried to spore stage, mixed with corn meal, and pressed into cakes. This yeast will keep for several months under ordinary storage. As the dried plants are inactive they take some time to become active again after warmth, moisture, food, and air are supplied. When dried yeast is used for baking, the sponge method should be used.

(3) *Baking powder*.—The leavening best suited for the production of pancakes, biscuits, cakes, and doughnuts is baking powder. Baking powders may be classified by rapidity of gas release as slow or quick acting. Quick-acting will release all of the leavening gas (carbon dioxide) in the cold when added to the dough. The slow acting will release part of the gas in the cold but requires heat to complete the action. Some slow acting baking powders are also known as “double acting” as part of the action takes place in the cold and part after exposure to heat. The quick acting baking powders are not suitable for the baking of pancakes or doughnuts as the leavening escapes from the dough while waiting to be baked. A general rule to follow in the use of baking powder is one-half ounce of slow or double acting powder to 1 pound of flour or 1 ounce of quick acting baking powder to 1 pound of flour. Use of the following table will assist the cook in determining what powder he is using:

Ingredients as stated on label	Action	Amount per pound of flour
Cream of tartar, and/or tartaric acid, bicarbonate of soda, starch.	Quick-----	Ounce 1
Calcium acid phosphate, bicarbonate of soda, starch. Sodium aluminum sulfate (SAS), monocalcium phosphate, bicarbonate of soda.	Slow or double-- -----do-----	$\frac{1}{2}$ $\frac{1}{2}$

(4) *Baking soda*.—Baking soda may be used as a leavening agent in the presence of acid, that is, with sour milk or vinegar. Canned milk can be converted into sour milk by adding 3 tablespoonfuls of vinegar to a 14½-ounce can of evaporated milk. Baking soda is also used in baking of cakes where an acid product such as chocolate is used to neutralize the acid for proper leavening effect and give the chocolate a darker color.

(5) *Eggs*.—Eggs are used for leavening cakes made without

Public Domain, Google-digitized / http://www.hathitrust.org/access_use#pd-gooole

shortening, such as sponge and angel cake. They serve as part of the leavening in "butter" cakes, muffins, and other quick breads.

(6) *Miscellaneous ingredients.*—The liquids used with yeast should be scalded to kill any organisms which might develop in the dough and then cooled to lukewarm before the yeast is added. The liquids used with baking powder should be at room temperature. All ingredients must be carefully measured or weighed to obtain best results. Excess amount of any one ingredient may result in an inferior product or failure.

(7) *Oven temperatures.*—The proper control of oven temperatures is another important procedure in baking. Pies should be placed in a hot oven, 500° F. for 10 minutes to set the shortening in the dough and then reduced to 350° F. to bake the filling. Bread should be baked at 450° F. to obtain the best volume and texture. The sweeter products should be baked at lower temperatures to avoid burning the sugar; sweet doughs at 400° F. and cakes at 350° F.

65. Beverages.—The beverages most used in Army messes are coffee, tea, cocoa, and lemonade. Fruit punches may be served occasionally in hot weather if the cost is moderate.

a. Coffee.—(1) *Rules for making.*—In brewing coffee by any method, the following rules should be strictly observed:

(a) *Keep supply of roasted coffee in airtight containers.*—Exposure to air causes roasted coffee to lose rapidly some of its flavor and strength.

(b) *Use ground coffee only once.*—Coffee grounds from which coffee has been made should always be thrown away. Never use them the second time. Coffee made from them is sure to have a bitter and unpleasant flavor. This is true even if fresh roasted coffee and old grounds are mixed. To mix fresh coffee and old grounds is a waste, not a saving.

(c) *Use fresh boiling water.*—The water must be boiling to extract all the desirable flavors from the coffee. It must be fresh. Water which has boiled for a long time has a flat taste which will appear in the coffee.

(d) *Regulate preparation of coffee so that it will be ready not more than 10 minutes before serving time.*—Once prepared, coffee loses its flavor rapidly and if held more than 30 minutes becomes bitter.

(e) *Never make more than enough coffee for one meal.*—Warmed-over coffee is bitter and has lost aroma.

(f) *Scour coffeepot.*—Unless thoroughly scoured daily, some of the spent grounds and oils of the coffee will stick in the corners of the pot and impart a bitter taste to subsequent brews.

(g) *If filter bags are used, they should not be dried, neither should they be washed in hot water.*—Hot water cooks in the coffee stains throughout the filter bag and, in subsequent brews, imparts a bitter and off flavor to the coffee. After the bag is rinsed in cold water, submerge it in cool or cold water until time to use it again.

(2) *Coffee for cooks.*—It is the practice of some cooks to make the coffee for breakfast as soon as the fire is started in the morning in order to have coffee for themselves. This is bad practice. It means that stale and bitter coffee is served at the mess table. Every mess should have a small coffeepot, percolator, or tricolorator for the purpose of providing good hot coffee for the kitchen detail, members of the guard, etc., who desire coffee earlier or later than the regular serving time for the organization. In making small quantities, use a level tablespoonful of ground coffee to each cup of water and add 1 level tablespoonful for the pot.

(3) *Proper quantities.*—One pint of coffee per man is ample for one meal. This is $12\frac{1}{2}$ gallons for 100 men or $2\frac{1}{2}$ gallons for 20 men. For each 20 men use 1 pound of roasted and ground coffee and $2\frac{1}{2}$ gallons of water. Therefore, to find the number of pounds of roasted and ground coffee, divide the number of men to be served by 20. For example, if 80 men are to be served, 4 pounds of coffee are required. To find the number of gallons of water, multiply the number of pounds of ground coffee by $2\frac{1}{2}$. Thus, for 80 men, 4 pounds of ground coffee and 10 gallons of water are required. These proportions of ground coffee and water should be used regardless of the method of preparation—whether boiled, or made in percolators, tricolorator, etc.

(4) *Methods of brewing.*—(a) *Boiled coffee.*—Heat fresh water in a separate container until it has just reached the boiling point. Place the ground coffee in a cloth sack; tie the top. Ground coffee expands in water, therefore leave plenty of room in the sack for this expansion. Place the sack of ground coffee in the coffeepot or boiler and pour the water over it; or, the sack of coffee may be suspended or dropped into the water. Keep hot on the back of the stove; do not permit boiling. The value of a cloth sack is that the grounds can be removed easily as soon as the coffee is brewed. Sometimes a sack may not be available. In this case the ground coffee is placed in the bottom of the pot or boiler and the boiling water poured over it; at the end of 10 minutes heating over a slow fire, settle the coffee by the addition of a small quantity of cold water.

(b) *Percolated coffee.*—Use either cold or hot water. The use of hot water reduces the length of time required to complete the brew.

For quantities in excess of 20 cups the coffee will be ready to serve in 10 minutes after it starts coming over the top of the tube. For smaller quantities 8 minutes is sufficient.

(c) *Filtered or drip coffee.*—This is made in a utensil having three compartments, the upper for water, the center for ground coffee, and the lower for the brewed beverage. Filter papers are usually provided to be placed on the bottom of the center compartment before putting in the ground coffee. This type of utensil is sold under various trade names as “Tricolator,” “Filtrator,” etc. For best results the coffee must be finely ground. Place the filter paper in the bottom of the center compartment, add the ground coffee and cover with the perforated metal cover which is usually provided; then pour in boiling or fresh water. When all the water has filtered through the ground coffee and into the lower compartment, the beverage is ready to serve. Before serving, stir the beverage to equalize strength throughout. Some arrangement must be made to keep the lower compartment hot but not boiling. If of earthenware or glassware, keep it in a pan of hot water until just before serving. If of aluminum or other metal it should be placed on the back of the stove. Do not permit the brewed coffee to boil.

b. *Tea.*—(1) Tea should be served hot occasionally in lieu of coffee. In the summer months it should be served often as an iced beverage, especially at the noon meal.

(2) Tea should be made in glass or earthenware utensils, if available, as metal utensils give an off flavor and tend to blacken the tea.

(3) One to three ounces of tea to 1 gallon of water should be used in making tea, depending on the quality of the tea and the strength of the beverage desired. Two ounces of tea leaves to 1 gallon of water should make a beverage to suit the average person.

(4) Bring the required quantity of water to a boil. Place the dry tea in a clean cotton bag, tie the top, and drop the bag into the boiling water. Tea expands in water, therefore, leave plenty of room in the bag for expansion. Allow the bag of tea to remain in the water for 5 or 7 minutes, then remove it. If tea leaves are allowed to remain in the water longer than 7 minutes the tea becomes stronger and bitter. Agitate the bag of tea three or four times during the period it is in the water. Stir the tea just before serving, to equalize strength throughout. If not stirred the tea on the bottom of the container will be stronger than that on top. Unlike coffee, tea may be made several hours before serving, if kept in earthenware or glass containers, as it does not lose its flavor and aroma. If lemons are available, they may be sliced and served with the tea in lieu of milk, for those desiring this.

(5) Tea to be used as an iced drink should be made in concentrated form. Use the total required quantity of tea leaves, and one-fifth the required amount of water. Prepare the same as hot tea, but a sufficient time in advance to permit cooling. Just before serving, add the remainder of the water, either cold water or chipped ice or a combination of the two, and stir vigorously in order to equalize strength throughout. Added lemon materially improves the flavor.

c. Cocoa.—(1) Cocoa makes a good beverage, especially for the evening meal. Five ounces of cocoa to 1 gallon of liquid makes a beverage of average strength. The best results are obtained when the liquid used consists of 75 percent milk and 25 percent water. The quantity of milk may be reduced, with corresponding increase in the quantity of water when it becomes necessary to reduce cost. Cocoa made with water alone lacks palatability and body, and is generally unsatisfactory.

(2) Some cooks make cocoa by placing the ground cocoa in a pot, adding hot water, bringing to a boil, then adding sugar and milk. A better method is first to make a thick paste with the ground cocoa, sugar, and a little hot water. This method prevents lumpiness.

(3) Some cooks prefer to leave out the sugar when making cocoa so that the men may add it at the table according to individual taste. This is a matter of mess management.

SECTION V

RATIONS

	Paragraph
Definition	66
To whom issued.....	67
Army	68
Use of rations.....	69

66. Definition.—A ration is the allowance of food for the subsistence of one person for 1 day.

67. To whom issued.—Each soldier (and certain other military personnel) is authorized by Army Regulations to receive one ration each day he is on active service.

68. Army.—The following kinds of rations are provided:

- Garrison.
- Field.
- Travel.
- Filipino.

Each ration is intended for certain conditions of military service, and is made up to suit those conditions. For example, the travel ration consists chiefly of foods which do not require cooking and therefore

purchase of any desired kind of food. For example, if a company mess had a strength of 100 men on July 1 and the value of the ration for July is 30 cents, the quartermaster gives the mess credit for \$30. The mess may purchase food from the quartermaster up to a value of \$30; or if it purchases less than \$30 worth, it is entitled to the saving in cash. This is called the ration savings privilege. The cash savings go into the company fund and may be spent at any later date for food. For convenience, the accounts are settled by the quartermaster once a month.

b. Field ration.—(1) The field ration is that prescribed for use only in time of war or national emergency when the garrison ration is not used. It will be issued in kind and no ration savings will be allowed. Its components and substitutes will be prescribed by the War Department or the commander of the field forces and will consist of the following:

(*a*) *Field ration A.*—This ration will correspond as nearly as practicable to the components or substitutes therefor of the garrison ration. This type of field ration will be issued as often as circumstances will permit.

(*b*) *Field ration B.*—This ration will correspond as nearly as practicable to the components of field ration A with the exception that nonperishable processed or canned products will replace items of a perishable nature.

(*c*) *Field ration C.*—This ration will consist of previously cooked or prepared food, packed in hermetically sealed cans, which may be eaten either hot or cold, and will consist of six cans per ration as follows:

3 cans containing a meat and vegetable component.

3 cans containing crackers, sugar, soluble coffee, and a confection.

(*d*) *Field ration D.*—This ration will consist of three 4-ounce bars of concentrated chocolate.

(*e*) *Field ration K.*—This ration is intended for parachute, airborne, and highly mobile units. It consists of previously cooked or prepared food packed in boxes, wrapped so as to be impervious to moisture and gas. It consists of three boxes per ration, each containing especially fortified biscuits, canned meat, malted milk tablets, and chewing gum. The breakfast box also contains soluble coffee and sugar; the dinner box, bouillon paste; the supper box, lemonade powder.

(2) In time of war, types C, D, or K field rations are to be issued only upon order of the commander of the field forces. In time of

peace, such of these types as are available may, for training purposes, be utilized when directed by proper authority.

(3) When deemed advisable a combination of types C and D may constitute the field ration. This will normally consist of two cans of the meat and vegetable component, two cans of the crackers, sugar, and soluble coffee, and two each of the 4-ounce bars of concentrated chocolate.

69. Use of rations.—*a.* The cook is not concerned with the component articles of the garrison ration. The organization commander decides the kinds and quantities of foods to be purchased out of the money allowance. These foods need not be, and usually are not, exactly the same as the components of the garrison ration. The organization uses the money allowance to purchase foods required to prepare the dishes called for by the menu.

b. As the field ration is issued in kind, the Army cook is directly concerned with its components and substitutive articles which are published in AR 30-2210.

c. Conditions in the field are such that neither the organization commander, the mess sergeant, nor the cook knows in advance which component and which substitutive articles of the field ration will be received each day. Therefore, it may become necessary to combine two or more of the component or substitutive articles in order to make one dish. For example, there might be issued for 1 day fresh carrots and canned peas, neither in sufficient quantity to serve alone. They may be cooked together. When the field ration is being issued daily, an effort should be made to entirely consume the issue each day in order to avoid holding over any portion.

SECTION VI

KITCHEN MANAGEMENT

	Paragraph
Personal cleanliness of cooks.....	70
Cooking—definite plan of work.....	71
Cooking—assembling ingredients and utensils.....	72
Cooking stoves, ranges, and appliances; directions for use.....	73
Care of ranges and cooking utensils.....	74
Service of meals.....	75

70. Personal cleanliness of cooks.—*a.* It is of great importance that the cook keep himself scrupulously clean and in good physical condition at all times. No one desires to eat food prepared by a cook who is not clean. A cook who suffers from any ailment (a cold, or any other sickness) is a possible source of transmission of his ailment to others. If he does not keep himself clean he may transmit disease

germs to the food. He must wash his hands frequently, and always after visiting a latrine. He should shave, bathe, and change underwear at least daily, and oftener, if necessary, in warm weather. His outer clothing must be changed as soon as it becomes soiled. Fingernails should be kept trimmed short and free from dirt. Regulation haircuts are comfortable and sanitary and should be procured regularly. Because any illness contracted by a cook or other kitchen personnel may be readily transmitted to the entire command, they should immediately report any symptoms of illness, infection, or contagious disease for medical examination and treatment. The cook must be careful to avoid coughing or sneezing when this might carry germs into the food. All cuts, scalds, or burns, no matter how slight, should be treated immediately to prevent infection.

b. The white caps provided for cooks are not merely for ornament; they are to prevent hair, dandruff, or dust from the cook's hair falling into the food. White caps must be worn at all times when in the kitchen and white caps and coats when serving meals.

71. Cooking—definite plan of work.—This plan originates with the menu. The next step is the assembling or the preparation of the foods and other items for cooking. The third step is the cooking or preparation of the food for service. The fourth and final step is the serving of the food. By having a definite plan of work a cook can reduce the number of utensils used in preparation of the food and lessen the dishwashing required. A thoughtless cook often leaves a trail of unnecessarily soiled utensils behind him, thereby justly incurring the resentment of the kitchen police. In order to work rapidly and efficiently, and to spare himself and others unnecessary steps, the cook should first thoroughly understand the recipe upon which he is working. He should read the menu for the day and make definite plans for cooking and serving all the dishes and foods called for. Nothing is gained by starting work without a well-laid plan. The use of a little imagination and anticipation will avoid much unnecessary confusion and last-minute rushing. The cook should think of what he has to do, remember how he did it before, and then try to do it a little better than the last time. He should also observe how others do the same things and be alert to adopt any time- or labor-saving methods which he may see others use. Recipes should always be consulted as a guide unless one is sure from long experience that this is not necessary. All ingredients should be accurately weighed and measured in order that uniformity in quantity, volume, and flavor may be assured, and that proper and intelligent corrections or adjustments may be made in preparing better dishes or larger or smaller portions at another time.

72. Cooking—assembling ingredients and utensils.—It is important to have a place for each utensil and keep it there, clean and ready for use. Articles to be used, including the kitchen utensils and the food being prepared, should be assembled within easy reach of the cook's table or range, in order to save time and steps. For example, when preparing cake batter, many steps and much inconvenience will be saved if the articles required are placed conveniently at hand upon the table on which the work is to be done. Also, the fire in the range should be regulated prior to beginning the mixing. After getting one's hand into the batter there is no time to collect articles and regulate the fire, not to mention the inconvenience and messy operations resulting therefrom. This principle applies to all dishes prepared in the kitchen.

73. Cooking stoves, ranges, and appliances; directions for use.—*a.* Cooks should be thoroughly familiar with their ranges, steam kettles, and other cooking appliances; know how to operate them economically; know which parts thereof produce the greatest heat and under what conditions these appliances may be most efficiently operated. For example, the heat surface of the Army range No. 5 may be best used as follows:

0	0	0	0
5	4	3	1
0	0	0	0
5a	4a	3a	2

The No. 1 eye gives off the greatest amount of heat; the No. 2 next, Nos. 3, 3a, 4, and 4a next; and Nos. 5 and 5a the least. A food to be boiled should be placed on the No. 1 eye. Should it be desired to have the food simmer, the utensil must be removed to eye No. 5 or No. 5a. Tough meat which requires a long, slow process of cooking may be simmered until tender without fear of burning if placed on the No. 5 or No. 5a eye. For a moderate heat Nos. 3, 3a, 4, and 4a eyes can be used to advantage. Stewing requires a gentle heat applied for a long time.

b. Steam cookers, where available, provide an exceptionally rapid means of cooking fresh vegetables in quantities. These cookers are economical of fuel and labor. They produce food of excellent quality, with a natural tasty flavor, and with very small loss of the nourishing properties contained therein, and, in addition, require little or no attention and do not allow foods to scorch or burn. Pressure steam cookers should have an automatic steam cut-off which is controlled by the opening and shutting of the doors, to avoid accidental

scalding of personnel. In using electric ranges or electrical appliances of any kind for cooking, care must be taken to prevent damaging the heating elements by rough handling or spilled foods. Any food spilled on this equipment, particularly on the heating elements, should be cleaned up immediately. Mixing machines, chopping and slicing machines, grinders, etc., should be well cleaned immediately after using. All cutting edges should be kept sharp, and all machinery well oiled and free from rust, dirt, and grease.

74. Care of ranges and cooking utensils.—*a. Responsibility of cook.*—It is part of the duty of cooking to give the proper care to ranges, cooking utensils, and kitchen equipment. To do the best cooking it is essential that this equipment be kept in good condition. Careful observation of the following instructions will insure kitchen equipment being in good condition at all times.

b. Ranges.—(1) *Army range No. 5.*—The Army range No. 5 is the type installed in many company kitchens in permanent barracks.

(*a*) Frequent firing should be made with small amounts of coal instead of using large amounts with longer intervals between firings. This will provide an even heat and will result in a smaller consumption of fuel.

(*b*) Ashes under the firebox should be cleaned out frequently, several times a day if necessary. Grate bars will burn out quickly, that is, become warped and twisted, if ashes under the firebox are allowed to pile high enough to touch the grate bars.

(*c*) The oven should be swept out and the top and outer surfaces of the range and stovepipe rubbed with greasy cloth daily. A greasy cloth applied daily over the entire range keeps it in better condition than stove polish applied once a week.

(*d*) Not less than once each week the range should be thoroughly cleaned out. To do this remove the top and sweep the top of the oven, protecting the casing plates. Remove the soot with a scraper through the flue doors. The mantel should be wiped often with a damp cloth and, when necessary, washed with soap and water. This prevents dishes picking up dirt and grease and thus soiling the tables.

(*e*) An intensely hot fire should never be maintained. Such a fire is not necessary for good cooking; on the contrary, it often causes poor cooking, as foods being cooked on top of the range may become scorched and those in the oven scorched or overcooked. An intensely hot fire tends to damage hot water piping and warp the top sections of the range.

(2) *Army field range.*—See paragraph 77.

(3) *Electric*.—The chief point to consider in using electric ranges is to avoid damage to the heating elements through rough handling and spilling of food on the range or heating elements. Any food spilled should be cleaned off immediately.

(4) *Gas*.—If foods are spilled on the burners of gas ranges, the holes will close up, thus cutting off heat. The burners should be kept clean. If the gas range does not appear to be heating well, the matter should be reported for the attention of a plumber who may be able to effect improvement by adjusting the air supply to the burners.

c. Utensils.—(1) *General*.—Tinned utensils, such as boilers, dip-pers, meat forks, ladles, skimmers, measures, basting spoons, etc., should be cleaned with soap and water, or scoured, if necessary, with fine scouring soap or wood ashes each time after using. They should then be scalded and air-dried (sunned if possible) and hung in a dry place. When tinned utensils become rusted they are unsanitary and should be reported to the mess sergeant. Towels should not be used to dry utensils or dishes if they can be air-dried. Usually the heat of scalding is sufficient to dry dishes but is not always sufficient to dry metal utensils, especially such utensils as egg beaters. If these utensils are placed on a clean stove mantel the heat will dry them.

(2) *Small utensils*.—It should be remembered that unclean utensils, knives, forks, spoons, egg beaters, etc., may impart an unpleasant flavor to any dish in which they are used; also, that germs are in the air everywhere, even in the cleanest kitchen. Therefore, every utensil should be cleaned immediately after use by washing in warm water and then rinsing in scalding water. This rinsing in scalding water will kill germs. It is not necessary to clean (wash) the utensils in scalding water; frequently this is bad practice, as scalding tends to cook the food, especially eggs, on the utensils and makes it more difficult to remove. Even though utensils have been cleaned before being hung up or put away they should be rinsed or dipped in scalding water before being used to kill germs or remove dust which may be settled on them. Large utensils, as tinned boilers, should be wiped before using.

(3) *Black iron bakepans*.—(a) *When received*.—The black iron roasting and baking pans supplied to Army messes should be washed when first received in the mess, in warm soapy water to which a little washing soda has been added. In the case of new and unused pans, this is to remove the protective paraffin coating put on by the manufacturer.

(b) *"Burning in" newly received pans.*—It should be a routine practice to "burn in" black iron pans when first received by the mess. After being washed and dried, the pans should be thinly and evenly coated with lard or lard substitute. Lard is better, but lard substitute will do. Then the pans are placed in a medium oven (325° to 400° F.—12 to 16 counts) for 1 hour. This burns in the coating of lard and gives a smooth, glazed surface, closing up the tiny pores in the metal and preventing rust. This process is often called "bluing" or "rebluing."

(c) *Periodical rebluing.*—Daily use in the mess causes the burned-in coating on these pans to wear off, this being indicated by shiny, light-colored areas. When this occurs the pans should be washed, dried, and reblued by the method shown in (b) above.

(d) *Cleaning.*—Black iron pans must be kept thoroughly clean inside and out. If particles of cooked food or dirt are left on the outside, they may be transferred to other pans when the pans are nested. Particles of cooked food or dirt on the inside of a pan will discolor and impart an unpleasant flavor to any food subsequently cooked or baked in such a pan. Black iron pans should be scoured only when necessary to remove dirt as scouring tends to remove the bluing. Soaking will soften most dirt so that it can be removed by washing in warm, soapy water. After washing, scald, air-dry (by heat if possible), and hang separately (not nested).

75. Service of meals.—*a. General.*—Under the direction of the mess sergeant, the senior cook on duty is responsible for the service of meals; that is, that foods are ready at the proper time and placed on serving dishes in an attractive manner. It is of little use to exercise great care in cooking a food if it is to be sent to the mess table presenting an unattractive appearance. On the other hand, the plainest foods become appealing when served in an attractive manner. Many men will eat an attractively served plain food which they would not eat if served in an ordinary manner. Therefore, every cook should know how to serve attractively.

b. Placing foods on dishes.—(1) Roast meats, as beef, veal, pork, and lamb, should be of uniform thickness and the slices laid evenly and neatly on the platter. If gravy is spilled on the edges of the platter it should be wiped away.

(2) Soft foods, as mush, mashed potatoes, turnips, etc., should be neatly rounded off, not merely thrown into the dish.

(3) Foods intended to be served hot, as soups, meats, vegetables, beverages, etc., should be actually hot. Nothing is so disappointing as lukewarm soup or coffee. Serving dishes should be kept warm,

either by being placed on the range mantel or by other means. Cold foods should be actually cold, and the cook must use foresight to chill them sufficiently in advance of serving to accomplish this. Hot or cold foods should not be placed on the tables until just before the men are seated; other foods may be placed earlier.

(4) Pies and cakes should be neatly cut. Pieces of cake should be neatly arranged on the serving dish without excess loose crumbs.

(5) A little cracked ice added to butter, olives, etc., and to fresh raw vegetables, as radishes, green onions, lettuce, celery, sliced tomatoes, etc., before they are sent to the tables makes these foods much more appetizing.

(6) Fresh fruits, as apples, oranges, pears, grapes, bananas, etc., are much more palatable when served chilled, and therefore should be thoroughly chilled before serving. It is economical and good mess practice to halve oranges, apples, and pears before serving, to prevent their being carried from the mess hall, and to encourage the consumption of fresh fruits at the table. A saving can be made in this way, as some men will not eat a whole apple or other fruit; also the freshly cut fruit seems to have a greater appeal to the men. Large bunches of grapes should be cut into smaller bunches.

c. Garnishing.—(1) *General.*—One of the best ways to make food attractive is by garnishing. The effect of color contrast is very pleasing. For example, a cabbage salad is much more attractive if a few strips of pimento and green pepper are spread over the top of the salad. A little paprika sprinkled over mashed potatoes or potato salad makes them more appetizing and appealing.

(2) *Methods.*—Following are some methods of garnishing:

(a) Many materials may be used to garnish roast meats. Sprinkle parsley over the meat and arrange a little around the edge of the platter. Add a few slices of fresh tomato, or a few french fried potatoes, or small quantities of green lima beans, diced celery, small whole boiled onions, green peas, sliced green pepper, or cooked carrots and turnips to the serving platter.

(b) When liver and bacon are served, instead of placing all the bacon in a separate dish, lay a few strips over the liver.

(c) Baked fish, salmon hash, fried oysters, etc., may be garnished with a few crescent-shaped slices of lemon and may also be garnished with a little parsley and a few pieces of french fried potatoes.

(d) Soups, stews, and gravies are improved in appearance by sprinkling a little chopped parsley over the surface just before serving.

(e) Macaroni and cheese should be sprinkled with paprika.

(f) Garnish spinach with sliced hard-boiled eggs.

(g) Small slices of cheddar cheese with apple pie are much appreciated.

(h) A small quantity of sliced green peppers greatly improves the flavor of stewed tomatoes, especially if cooked with the tomatoes during the last few minutes of cooking.

(i) Many types of pudding can be greatly improved in taste and appearance by topping with shredded coconut and canned sour red cherries. Diced pineapple spread over cornstarch or tapioca pudding and then topped with thinly spread coconut improves appearance and adds to flavor.

(3) *Materials used for garnishing.*—Following is a list of some of the materials which can be used for garnishing. The quantity required and the cost are small:

Asparagus, in whole spears.

Bacon, fried.

Beans, lima, green, canned or cooked.

Beets, canned or cooked, sliced, diced, or cut into fancy shapes.

Cabbage, shredded.

Cantaloupe and other melons, cut into small balls.

Carrots, cooked, whole, halved, sliced, or cut into fancy shapes.

Cauliflower, small cooked pieces.

Celery, in stalks, sliced, or diced.

Celery leaves.

Cheese, cut or grated, or cream cheese.

Cherries, red or green.

Coconut, shredded.

Cucumbers, sliced or cut into fancy shapes.

Eggs, hard-boiled, sliced.

Endive.

Fruits of all kinds.

Lettuce, leaves or pieces.

Olives.

Onions, mature, small, boiled whole or pickled.

Onions, mature, sliced raw.

Onions, young, green.

Paprika.

Parsley.

Peas, green, canned or cooked.

Peppers, green, sliced thin.

Pickles, any kind, whole, halved, sliced, or cut into fancy shapes.

Pimentos, cut into strips.

Potatoes, french fried, or mashed and shaped into small balls, or put on serving dishes or individual plates with a pastry bag.

Radishes, whole, cut, or sliced.

Spinach, cooked.

Turnips, cooked, sliced, diced, or in fancy shapes.

SECTION VII

FIELD COOKING

	Paragraph
General instructions.....	76
Army field ranges, installing and handling.....	77
Army gasoline field range M1937.....	78
Installation of Army field range No. 1 in baggage car.....	79
Installation and use of Army field range M1937 on troop trains.....	80
Improvised ice box.....	81
Garbage.....	82

76. General instructions.—*a.* The fundamentals of cooking are the same in field as in garrison. The chief difference is in the equipment used. The cook must be familiar with the handling of wood fires and the gasoline burner. Usually too much heat is used with the gasoline burner and difficulty is experienced with the wood fire when not accustomed to it. As the field range M1937 can be operated with wood in case of necessity, the cook should be trained in the handling of both types of fuel.

b. The menu must be adjusted to accommodate the range to be used in the field. Part of the meal should be prepared on the top of the range and part in the oven. This is especially true when either field range No. 1 or No. 2 is used. The menu should also be planned to accommodate the mess kit. Dishes that require long cooking should be avoided when the cooking time is limited. Hot cakes should not be served unless they can be served direct from the griddle to the man. This requires time. Hot biscuits can be prepared in much less time and can be served hot from the oven without difficulty.

77. Army field ranges, installing and handling.—*a. When used.*—Army field ranges are used by troops in the field when not equipped with rolling kitchens or other cooking equipment.

b. Classification.—There are three types of field ranges—Army field range No. 1, Army field range No. 2, and Army gasoline field range M1937 (par. 78).

(1) *Description, installation, and operation of field range No. 1.*—

(*a*) Army field range No. 1, complete, weighs approximately 264 pounds with utensils, and with the addition of the Alamo attachment,

is designed to cook for 150 men. It consists essentially of two parts—the oven (No. 41) and the boiling plate. The boiling plate has three sections (No. 42, and the Alamo attachments, Nos. 42A and 42B).

(b) On the march, field range No. 1 is ordinarily set up by leveling the ground selected and placing the oven (No. 41) and boiling plate (No. 42) side by side, so that the oven door and the firebox door will be at the same end. Draw together 42A and 42B and secure bar lock. Insert 42 (boiling plate) into 42A and rest 42B snugly on the angle iron on the rear of the oven. The oven should not be banked as this would cause the sheet iron along the sides to warp and finally burn through. Sufficient earth, however, should be tamped along the sides and closed end to prevent the passage of gases beneath, but should not extend above the straps along the sides and under the oven door. (See fig. 19.) If heavy weights, such as large cans of water, are placed on the boiling plate, lay angle irons across the plate so that the weight will come on the walls and not on the center of the plate. This will prevent warping and breaking down the center of the plate.

(c) When used for 1 day only, a few shovelfuls of earth should be removed from the place to be covered by the boiling plate (see fig. 19) to facilitate firing. The best results are obtained by using short

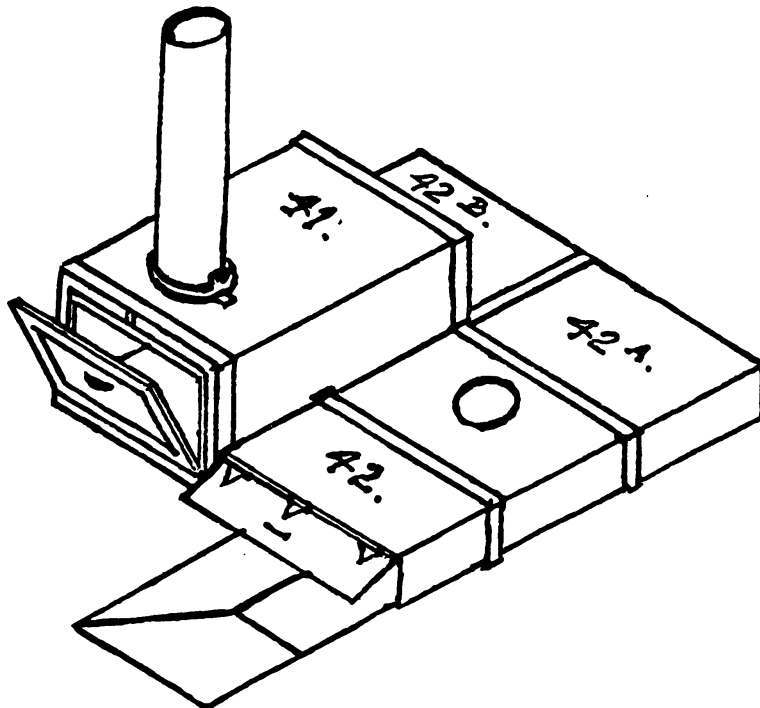

FIGURE 19.—Sketch of Army field range No. 1, with Alamo attachments, assembled for use in the field.

wood, keeping the fire well toward the firing end of the boiling plate; or, if using long sticks and branches, pushing them under the boiling plate as they are consumed.

(d) If the range is to remain in place for several days, it is best to dig a trench (except in sandy soil) about 18 inches wide by 6 inches deep at the front and the length of the boiling plate, say 6 feet, sloping upward to about 5 inches in depth at the back end (fig. 20).

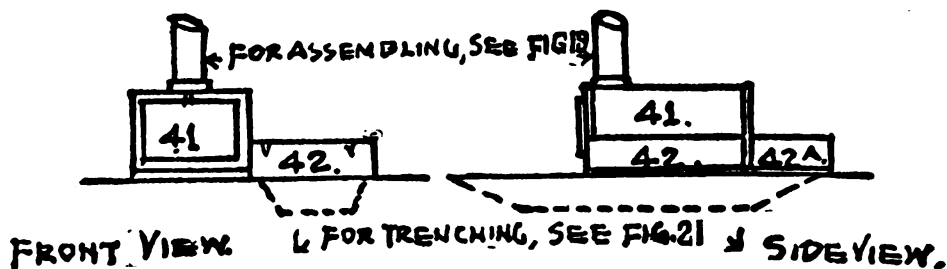

FIGURE 20.—Sketch of range with or without trench.

When installed, the trench should extend under the boiling plate and about 1 foot under the Alamo attachment (just enough to facilitate the draft) and about 6 inches under the oven. When the range is set up on different ground daily, no difficulty will be experienced in obtaining the proper temperature in the oven, both for top and bottom heat. Whenever it remains in the same spot for a longer time than 1 day, the ground will become dried out and hot, and it may be necessary to raise the bakepans about 2 inches off the floor of the oven. This can be done easily by the use of angle irons or other means, thereby causing an air space under the bakepans. Never use earth or sand for this purpose as it would cause a hole to burn in the bottom plate of the oven.

(e) If the range is to be used for a considerable length of time in one location it should be elevated on a base of bricks or of stones and clay. In this case no trenches are dug under the range. The ground is leveled, and a brick floor may be laid if sufficient bricks are available. Set up the range, temporarily, on the level ground or on the brick floor, and mark the outline of the range. Then remove the range and attachments and construct a wall, 3 bricks high and 8 inches wide on the line and on the line between the oven and boiling plate. Assemble the range on top of the brick walls. Under the oven place a number of bricks on edge, spaced $\frac{3}{4}$ -inch apart. These hold the heat and improve baking. The spaces (fire channel) inside the brick walls under boiling plate No. 42 and gas chamber under Alamo attachments Nos. 42A and 42B, and under oven are about

the same as if a trench had been dug as in figure 21. Bank outside of brick walls at sides and back of range with clean earth.

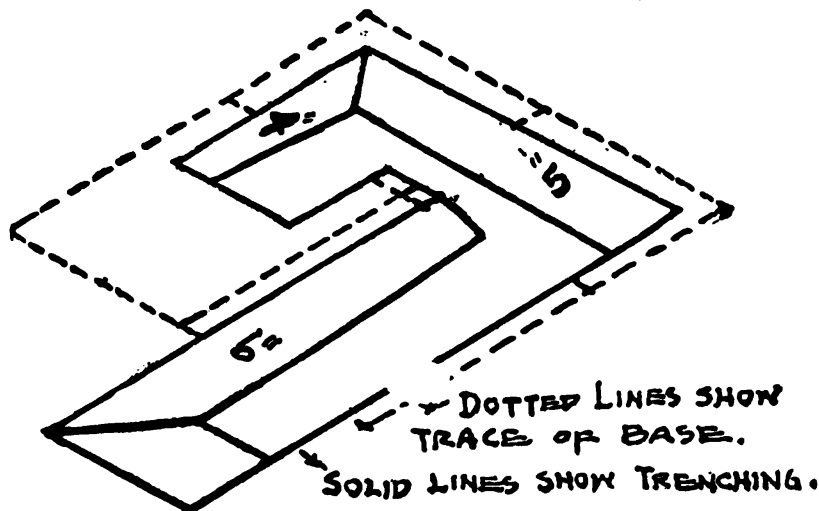

FIGURE 21.—Sketch of trenching for range with attachments.

(f) At times it may be necessary to install this range for cooking on a railroad car or on a wooden floor of a house, shed, etc. To install, erect a frame 12 inches high, 6 feet long, and 4 feet 6 inches wide; fill with sand and set the oven and boiling plate on top of the sand, anchoring firmly in place. If clay is available, remove all stones, pebbles, etc.; add salt water, and sand. This foundation will become hard and solid and will prevent the burning of the floor.

(2) *Description, installation, and operation of field range No. 2.*—

(a) The Army field range No. 2, complete, weighs about 150 pounds with utensils, and is designed to cook for 55 men. This range does not have the Alamo attachments. It consists essentially of two parts—the oven (No. 61) and boiling plate (No. 62).

(b) Field range No. 2 is set up practically the same as No. 1, the boiling plate being placed in position and the projecting collar being slipped into the space cut from one end of the oven for that purpose. The fire is maintained in the same manner as when using the No. 1 range.

(c) If the range is to remain in place for several days, it is best to dig a trench, except in sandy soil, about 16 inches wide by 6 inches deep, and of sufficient length for free fueling, say 5 feet (see fig. 22). When installed, the trench should extend under the boiling plate and about 3 inches under the oven—just enough to prevent choking of the draft. If the flame is allowed to play freely on the bottom of the oven chamber, it will become too hot for baking and the bottom of the oven will soon burn out.

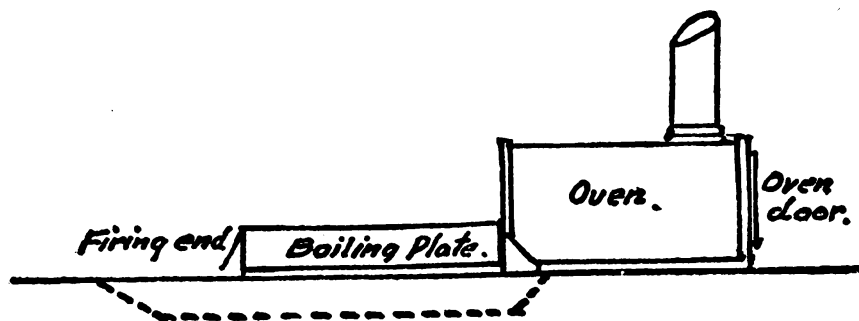

FIGURE 22.

c. Remarks on handling ranges.—(1) *Care of ranges.*—(a) A tin will be found inside the baking chamber which may be used if for any reason the bottom of the oven is too hot. Should the bottom be too cold for efficient baking the tin should be removed.

(b) Coal should never be used when wood is obtainable. If possible, even when coal is used, part of the fuel should be wood, for the use of coal alone will quickly destroy the range.

(c) In permanent camp, the space above and on the sides of the oven and stovepipe should be cleaned at least once a week. This also applies to the boiling plates.

(2) *Assemblage for transportation.*—When breaking camp and assembling range No. 1 for transportation, draw boiling plate No. 42 forward. Unfasten the bar lock, pull apart, and remove Nos. 42A and 42B and proceed as indicated below:

(a) To pack the utensils and range No. 1 for transportation, place the bakepan No. 52 on the ground. Set boiler No. 50 inside of bakepan No. 52 and boiler No. 51 inside of boiler No. 50. Place tent guards inside of boiler No. 51 on bottom. Telescope the four joints of pipe. Inside of the pipe place two forks, three knives, one steel, one cleaver, and two folding lanterns. Place joints of pipe containing utensils inside of boiler No. 51. Place meat chopper in boiler No. 51 alongside of joints of pipe. Place two basting spoons, one meat saw, and one skimmer in boiler No. 51, on top of pipe. Cover with lid No. 51 and then lid No. 50. Place bakepan No. 52 upside down over lid No. 50. Care should be taken that bakepan handles are well down to the sides of the pan. Place stovepipe elbow in No. 54. Place dippers alongside of elbow. Place covers Nos. 54, 53, 49, and 48 on boilers in order named. Place nested boilers Nos. 48, 49, 53, and 54 in rear end of oven. Place bakepan and nested boilers Nos. 50 and 51 in front end of oven. Close the oven door and lock with damper lock. Place No. 42A on left front corner of oven No. 41, and

No. 42B on right front corner, inserting bar in crimp. This bar now rests against the pipe collar and prevents sliding. Place boiling plate No. 42 on top of range, eye fitting over stovepipe flange and engaging

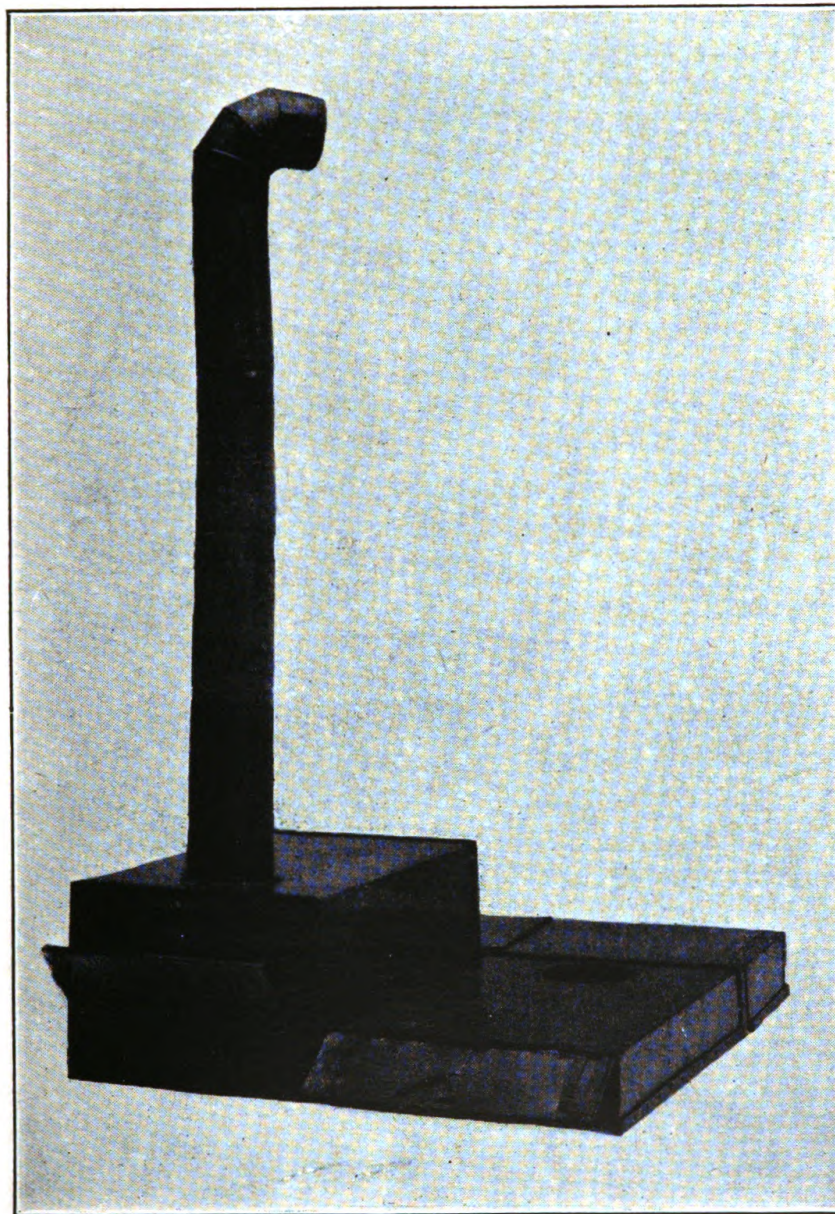

FIGURE 23.—Field range No. 1, set up, front and right side, with boiling plate and Alamo attachments.

under the flat hook. Make secure by fastening hook on front of boiling plate to the lug on back of range. The range is now secure for transportation. (See figs. 23 to 26, incl.)

(b) To pack utensils and range No. 2 for transportation, place bakepan No. 52 on the ground. Set boiler No. 50 inside of bakepan

No. 52 and boiler No. 51 inside of No. 50. Place tent guards on bottom of boiler No. 51. Telescope the four joints of stovepipe. Inside pipe place two forks, two knives, one steel, two spoons, one lantern



FIGURE 24.—Field range No. 1, set up, rear and right side, with boiling plate and Alamo attachments.

olding), and one skimmer. Place dipper and elbow alongside pipe. Place meat saw in bakepan No. 52 alongside of boilers. Cover boilers with lids Nos. 51 and 50. Place bakepan No. 52 upside down over lid No. 50. Place pans in range oven. Place the boiling plate at the door end of the oven. Engage the flanges on the inner edge of boiling plate with the lugs on the door end of the oven.

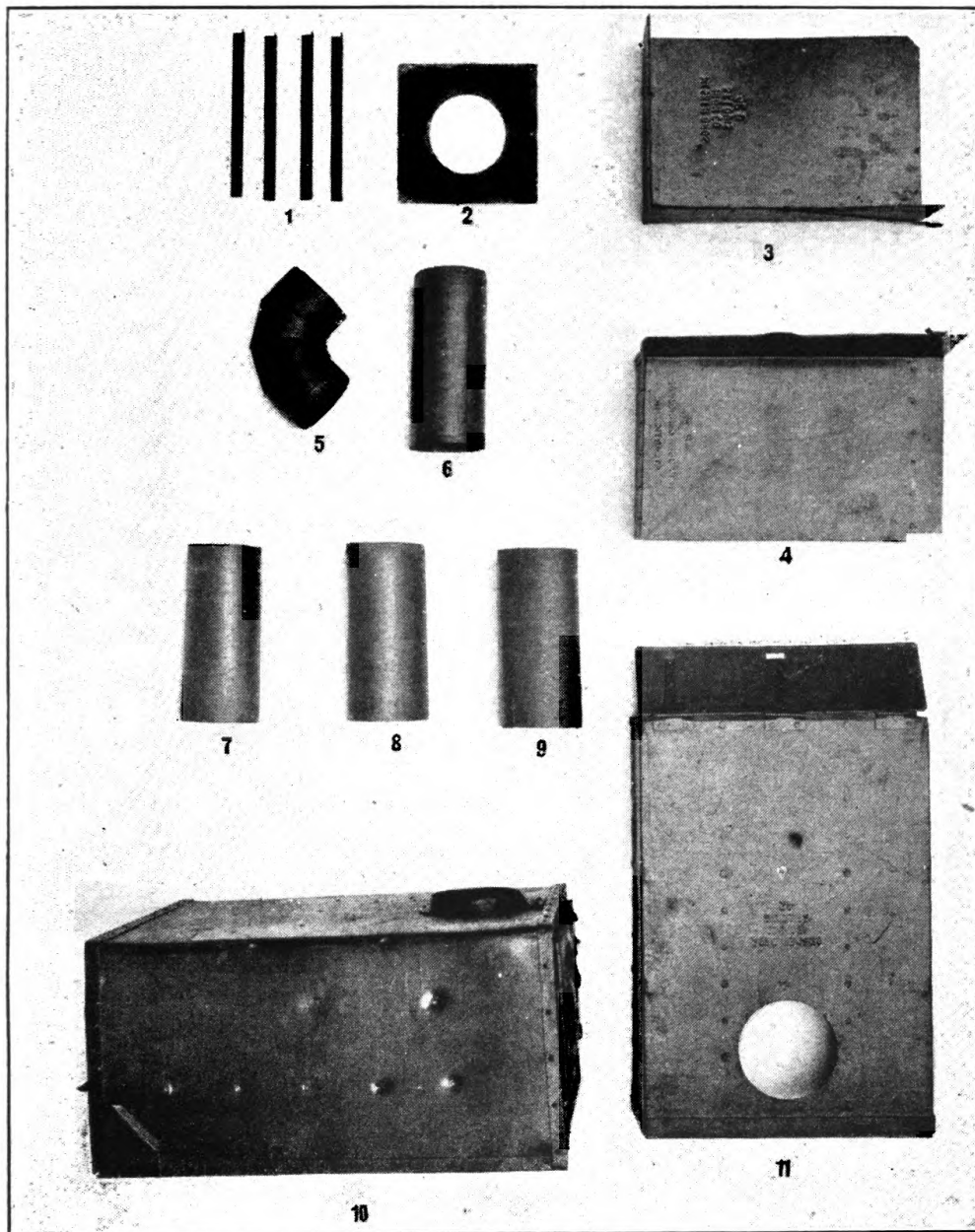

- | | |
|------------------------------------|------------------------------------|
| 1. Rests, pan, No. 57 (4). | 7. Pipe, stove, No. 45 (1). |
| 2. Guard, tent, 6½ inches (1). | 8. Pipe, stove, No. 44 (1). |
| 3. Attachment, Alamo, No. 42B (1). | 9. Pipe, stove, No. 43 (1). |
| 4. Attachment, Alamo, No. 42A (1). | 10. Body, field range, No. 41 (1). |
| 5. Elbow, 6-inch, No. 47 (1). | 11. Plate, boiling, No. 42 (1). |
| 6. Pipe, stove, No. 46 (1). | |

FIGURE 25.—Parts for field range No. 1.

Fasten the hook on boiling plate (firing end) to lug above the handle on the closed end of oven. The range is now secure for transportation. (See figs. 27, 28, and 29.)

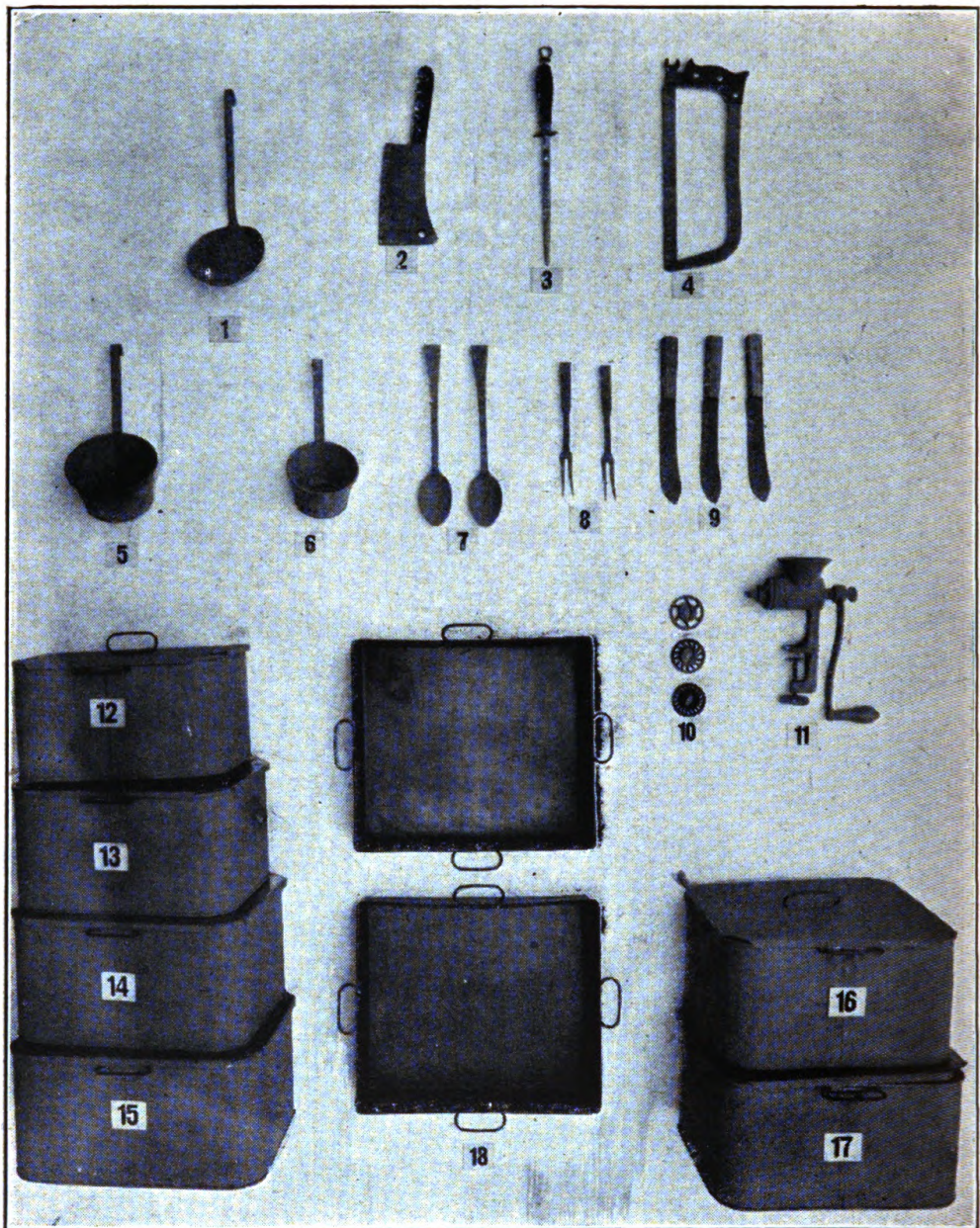

- | | |
|---|--|
| <ol style="list-style-type: none"> 1. Skimmer, large (1). 2. Cleaver, meat, 8-inch (1). 3. Steel, butcher, 10-inch (1). 4. Saw, meat, 14½-inch blade (1). 5. Dipper, 2-quart, No. 55 (1). 6. Dipper, 1-quart, No. 56 (1). 7. Spoons, basting, large (2). 8. Forks, meat, two prongs (2). 9. Knives, butcher, 8-inch (3). | <ol style="list-style-type: none"> 10. Cutters for meat grinders, assorted sizes (3). 11. Grinder, meat, small (1). 12. Boiler and cover No. 54 (1). 13. Boiler and cover No. 53 (1). 14. Boiler and cover No. 49 (1). 15. Boiler and cover No. 48 (1). 16. Boiler and cover No. 51 (1). 17. Boiler and cover No. 50 (1). 18. Bake pans No. 52 (2). |
|---|--|

FIGURE 26.—Utensils for field range No. 1.

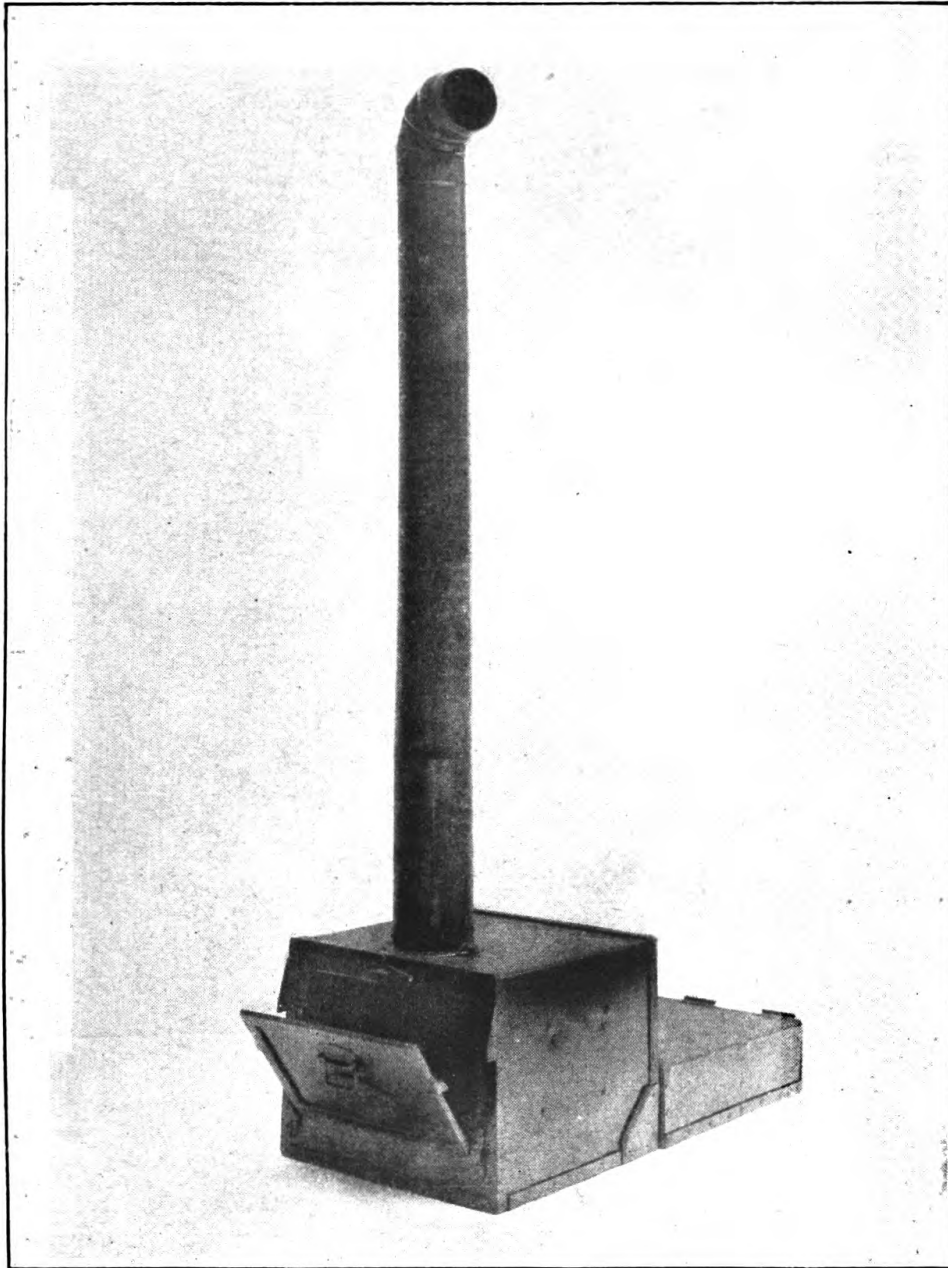

FIGURE 27.—Field range No. 2, set up, front and right side, with boiling plate.

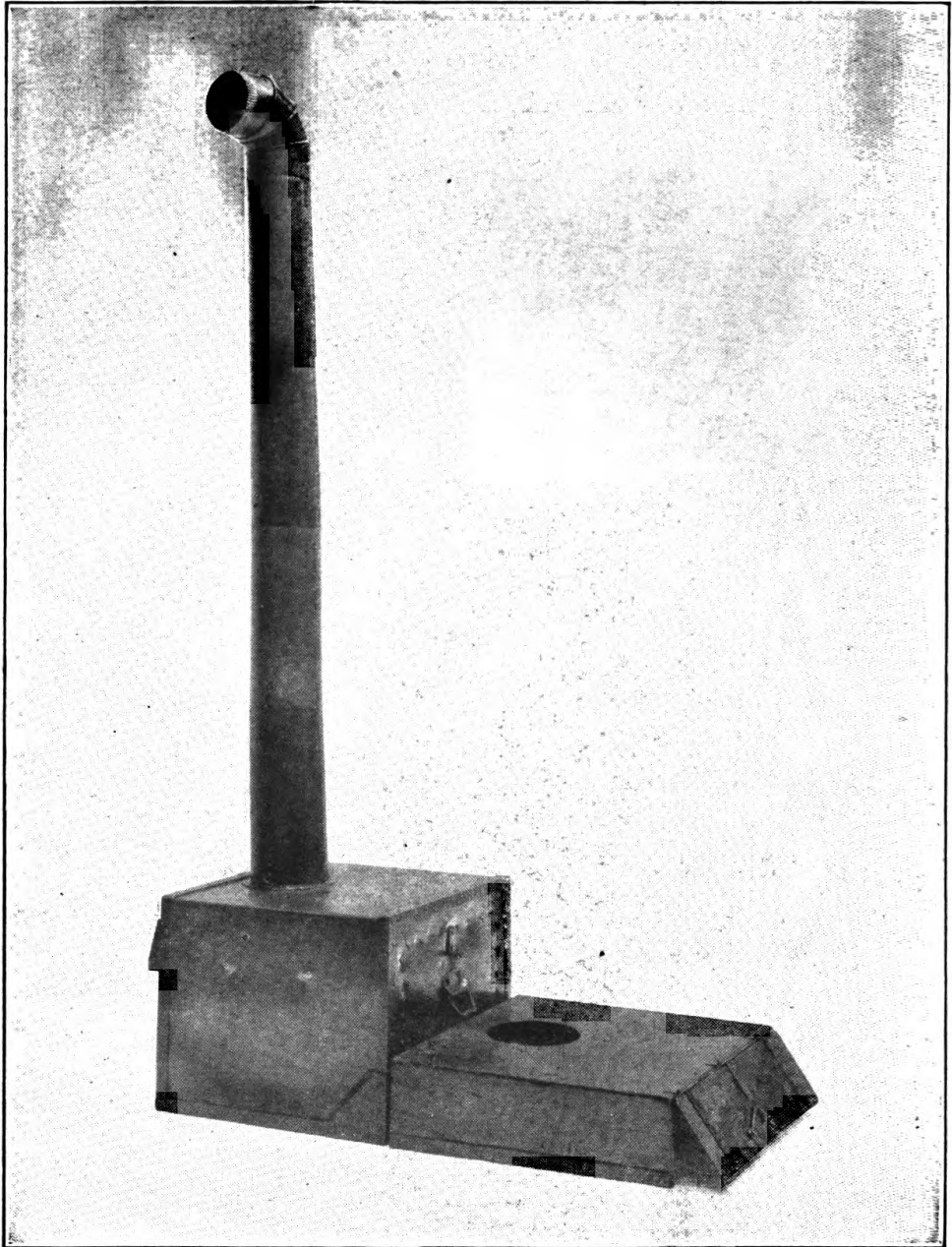
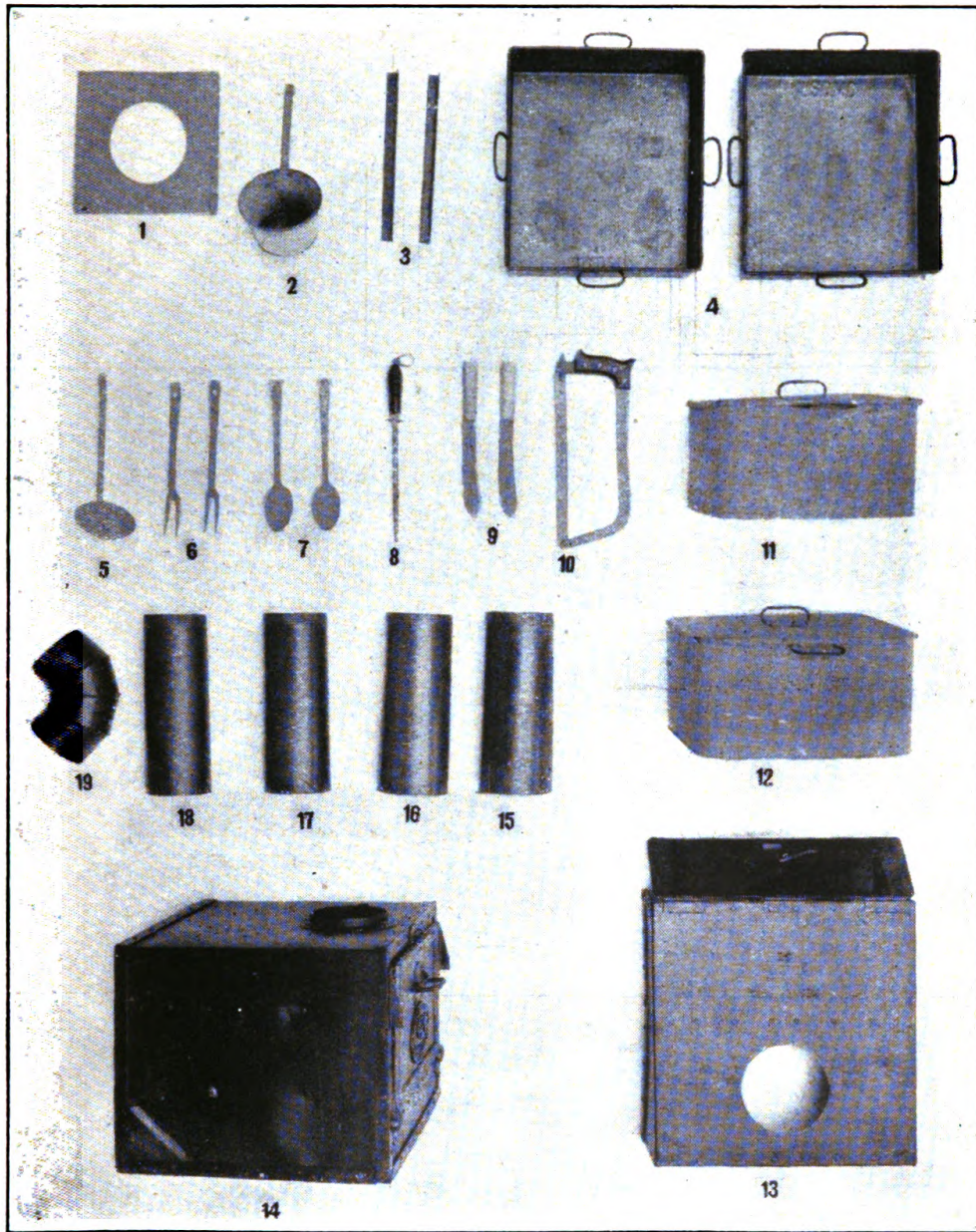

FIGURE 28.—Field range No. 2, set up, rear and right side, with boiling plate.



- | | |
|------------------------------------|------------------------------------|
| 1. Guard, tent (1 pair). | 11. Boiler and cover No. 51 (1). |
| 2. Dipper, 2 quart No. 55 (1). | 12. Boiler and cover No. 50 (1). |
| 3. Rests, pan No. 57 (2). | 13. Plate, boiling, No. 62 (1). |
| 4. Bakepans No. 52 (2). | 14. Body, field range, No. 61 (1). |
| 5. Skimmer, small (1). | 15. Pipe, stove, No. 63 (1). |
| 6. Forks, meat, two prongs (2). | 16. Pipe, stove, No. 64 (1). |
| 7. Spoons, basting, small (2). | 17. Pipe, stove, No. 65 (1). |
| 8. Steel, butcher, 10-inch (1). | 18. Pipe, stove, No. 66 (1). |
| 9. Knives, butcher, 8-inch (2). | 19. Elbow, No. 67 (1). |
| 10. Saw, meat, 14½-inch blade (1). | |

FIGURE 29.—Parts and utensils for field range No. 2.

78. Army gasoline field range M1937.—*a. Description of range.*—The range has been designed to perform a variety of cooking operations using gasoline as fuel. Either white or ethyl gasoline

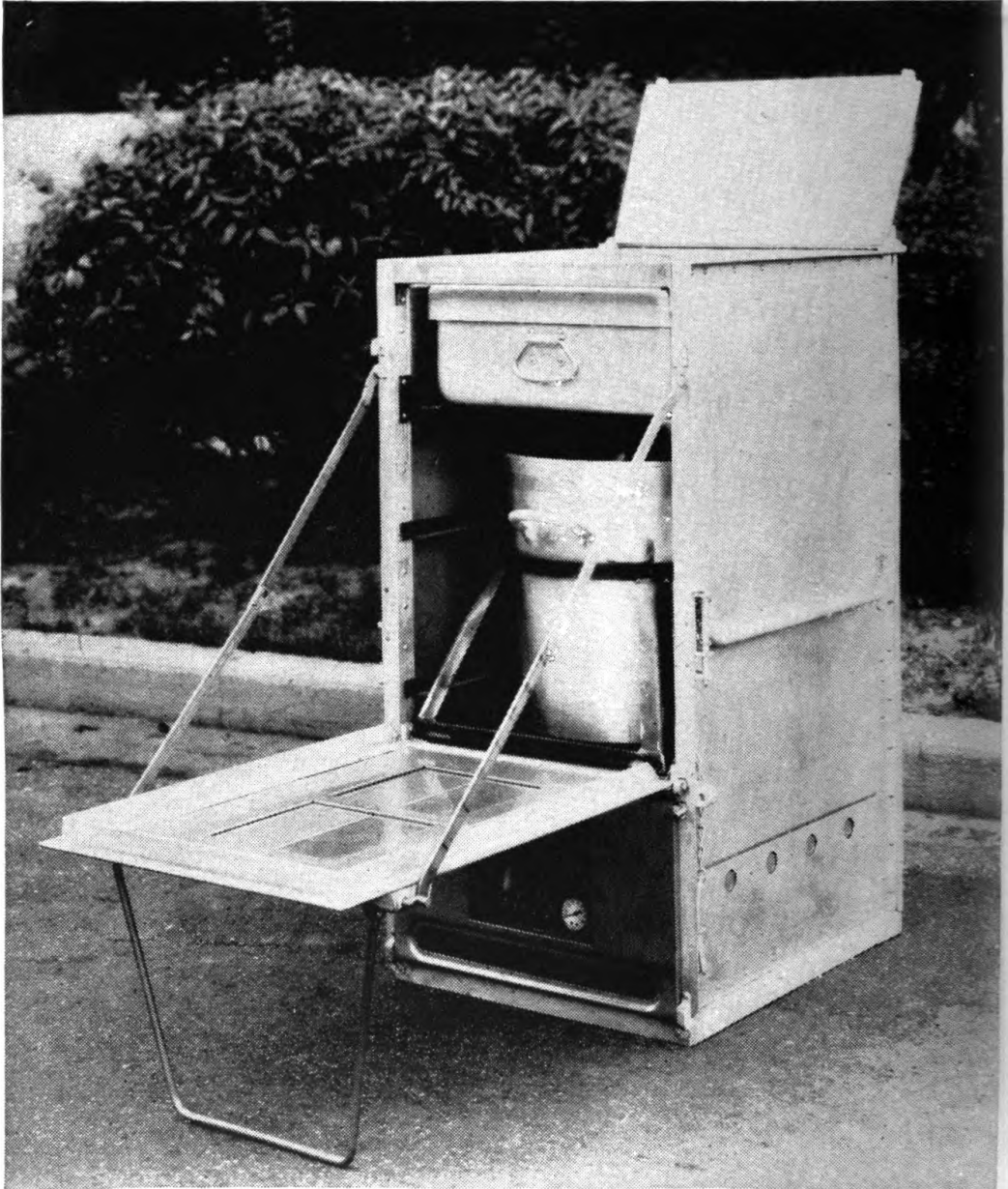

FIGURE 30.—One unit of range with cooking equipment in place.

may be used. In emergencies it may be operated with wood as fuel, a collapsible grate being provided for this purpose. The construction of the range in small units makes it suitable for any size organization (figs. 30, 31, and 32). One, two, or three units may be installed across

the front end of the 1½-ton truck, opening toward the rear of the truck. The fire unit is separate from the cabinet and may be used in



FIGURE 31.—One unit of range with cooking vessels uncovered, and in position for serving food.

three different positions in the cabinet. The fire unit may also be operated outside of the cabinet.

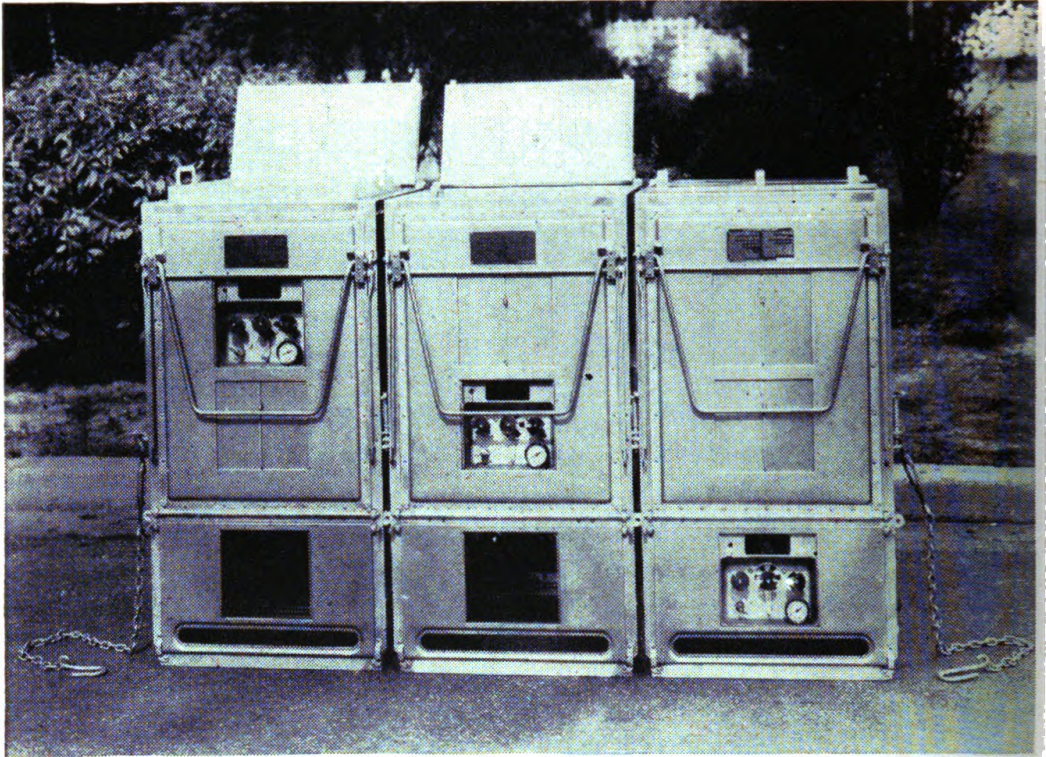
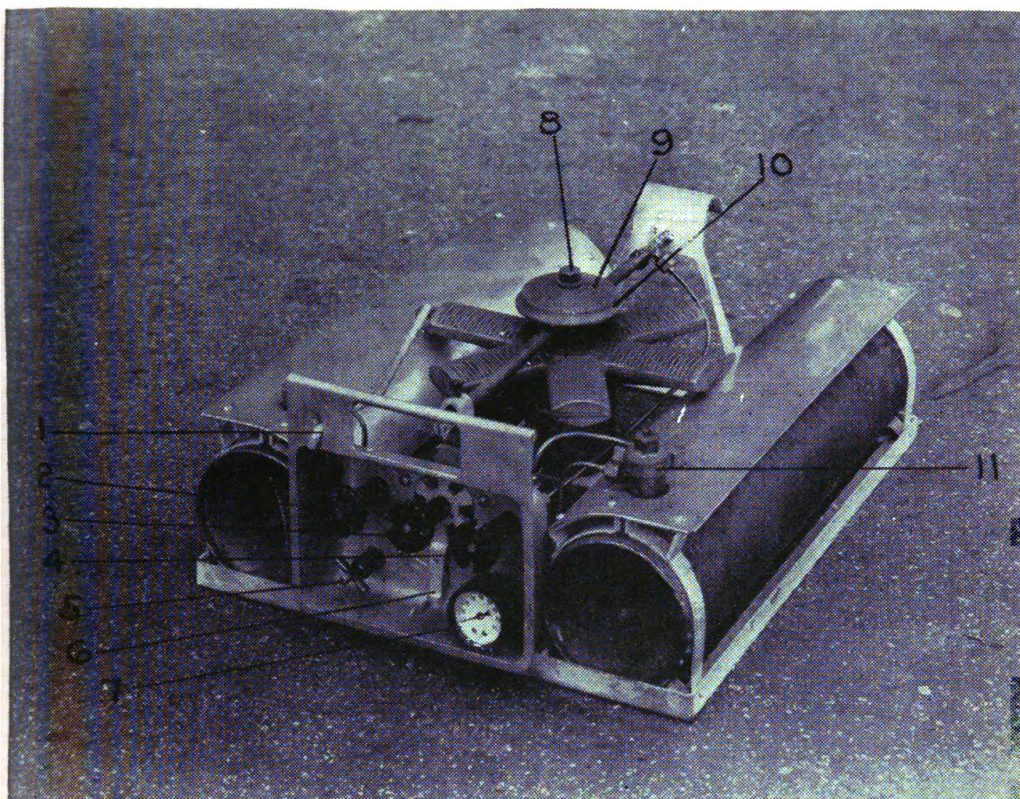

FIGURE 32.—Three units of range latched together for cooking in transport, showing tie-in chains for anchoring range in truck or railway car. (Right-hand unit is set up for boiling and roasting, middle unit for frying, and left-hand unit for griddle cooking).

- b. To operate fire unit (fig. 33).—*
- (1) Close all valves tight.
 - (2) Fill fuel tank and replace cap tight.
 - (3) Remove filter cap; remove dirty filter disk; wipe filter cap and body clean; insert new filter disk.
 - (4) Be certain ground joint is clean.
 - (5) Tighten filter cap screw firmly.
 - (6) Pump pressure to about 40 pounds.
 - (7) Pull out burner control rod.
 - (8) Open air shutter wide.
 - (9) Open air valve one-half turn.
 - (10) Open fuel valve one-half turn.
 - (11) Hold lighted match over end of burner arm and open flame valve one-half turn.
 - (12) After flame starts keep color *green* by adjusting *air* valve.
 - (13) When air valve can be *closed* generator is hot.
 - (14) Push in burner control rod.
 - (15) Regulate size of flame with flame valve.
 - (16) Keep flame green with air shutter.
 - (17) To stop flame, close *fuel valve*.
 - (18) Do *not* leave flame valve *closed* when hot.



- | | |
|-------------------------|----------------------------|
| 1. Rod, burner control. | 7. Gage, air pressure. |
| 2. Valve, air. | 8. Screw, filter case cap. |
| 3. Valve, flame. | 9. Cap, filter case. |
| 4. Valve, fuel. | 10. Body, filter case. |
| 5. Valve, air input. | 11. Cap, fuel tank. |
| 6. Shutter, air. | |

FIGURE 33.—Gasoline fire unit.

(19) In case of accidental fire, close fuel valve first and remove fire unit from cabinet.

c. Refueling fire unit.—Fill the fuel tank *before* each meal. The tank full of fuel will operate the range for about 4 hours. If refilling is necessary, be certain the flame *is out* and that the burner *is not hot*. Remember at all times that *gasoline is treacherous if not kept strictly in its place*.

d. To clean fire unit.—(1) Clean the shields with steel wool and gasoline or cleaning fluid.

(2) Remove dirt from the burner surface with the steel brush. Clean the slots with the burner slot cleaner.

(3) Clean the mirror surface with water or gasoline. Do not use steel wool on the mirror. Keep the mirror clean at all times.

(4) Remove the generator caps and take the filter case apart. Remove the generator yoke and lift out the generator. Clean all pas-

sages thoroughly with the generator cleaner wire. *Do not remove the generator tubes from the filter case body.*

(5) The fuel jet should be cleaned once a day. To clean the fuel jet, open the flame valve stem about one turn. Loosen the generator yoke screw and remove the flame valve from the front panel. Remove the flame valve nut, using the two open end wrenches. Clean the jet with the jet reamer, being sure that the reamer enters the jet up to the shoulder on the reamer. Replace the jet and pull the flame valve nut down *moderately* tight.

(6) The flame valve stem should be cleaned frequently. To clean the flame valve stem, unscrew the packing gland and remove the stem from the valve body. The packing gland must come out with the stem. Clean the socket on the side of the flame valve body and be certain that the end of the small generator tube fits properly in the socket before the generator yoke screw is tightened. Only moderate pressure should be used on this screw. Excessive tightening may distort or rupture the front panel. If a leak occurs at the flame valve socket, these parts should be resealed with valve grinding compound.

(7) Clean the filter and insert a new filter disk each time the jet is cleaned. After inserting a new filter disk in the filter cap be certain that all dirt particles are removed from the ground joint before the cap is put in place on the filter body.

(8) Apply graphite grease to the threads of the filter case cap screw and to the under side of the filter case cap screw gasket. Pull the cap screw down firmly with the wrench. Avoid excessive tightening of this screw.

e. Cooking operations.—Suitable temperatures for boiling in the cook pot and for roasting or baking in the roasting pan at the same time are produced when the fire unit is operated in the bottom position in the cabinet. Pies may be baked in the roasting pan. All other baking should be done in the baking pan placed inside of the roasting pan. Always put the cover on the roasting pan when roasting or baking and keep the top door of the range closed. Frying in deep fat is done in the roasting pan without the cover, the fire unit being used in the middle position. For griddle cooking the cover of the roasting pan is turned over and placed on the brackets in the top corners of the cabinet, the fire unit being in the top position.

f. Wood burning grate.—The wood burning grate (fig. 34) is provided with each unit of the range. It is carried, folded, in the bottom of the cabinet when not in use. It is used in the bottom fire unit position when the range is set up on the ground.

g. General care of range.—(1) Handle the range cabinet and burner carefully.

(2) Spilled food and grease should be removed promptly. Cleaning may be done with a scouring powder and rag or with steel wool and gasoline.

(3) Do not allow water to enter fuel tank. Invert the fire unit to remove water from the fuel tank.

(4) Remove rust from the burner slots by pickling for a few minutes in 50 percent solution of hot muriatic acid.

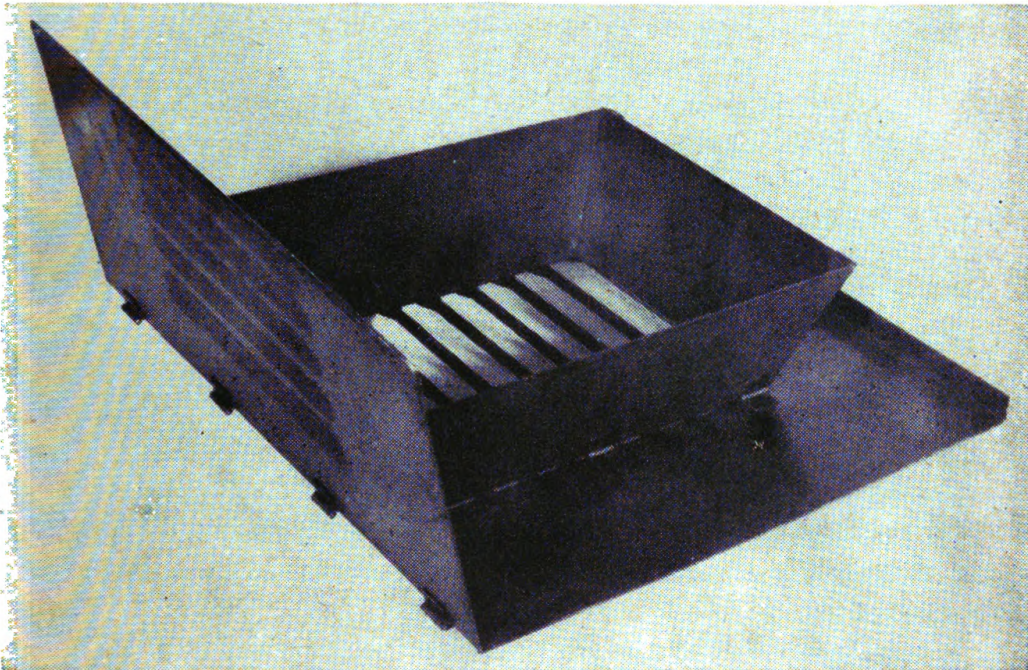

FIGURE 34.—Wood burning grate set up for use.

(5) Apply graphite grease to the cook pot cradle rails occasionally.

(6) Keep water in the cook pot whenever it is over the fire.

(7) Protect the filter case ground joint. Avoid dropping objects on the copper tubing.

(8) Use only the wrenches supplied with the range. Do not use pliers on any of the nuts.

h. Troubles and their treatment.—(1) A leak at the filter case ground joint, indicated by a yellow flame at the point of leakage, may be caused by an injured ground joint surface or by a loose cap screw.

(2) Tighten a loose screw, though not excessively. Tapping the filter case cap right over a leak may stop a small leak. Regrinding will be necessary when the ground joint surfaces have been injured. Grind as little as possible.

(3) *Much trouble is caused by tightening filter case cap screw too tight.* If the ground joint surfaces are clean, moderate tightening is sufficient.

(4) A leak at the flame valve socket may be caused by dirt in the socket, or by improper placing of the flame valve when the generator yoke is tightened. Be very careful to put the generator tube into this socket just right before the yoke screw is tightened. An injured socket joint may be repaired by grinding in with valve grinding compound.

(5) Excessive tightening of the generator yoke screw may fracture the front panel. Very moderate pressure will make this joint tight.

(6) Unions on the tubing fittings should be set up moderately tight.

(7) A yellow flame may be caused by dirt at the point of the flame valve stem. This may be removed by turning the valve stem back and forth while the flame is in operation.

(8) If the flame valve jet is not cleaned frequently the opening will be reduced by dirt. This condition may be remedied by closing the flame valve tight and reopening. Ream a dirty jet at the first chance.

(9) A dirty filter disk reduces the passage of fuel through the disk, and is indicated by a weak flame. Replace the dirty filter disk.

(10) If the passages in the filter case body and in the generator tubes are allowed to go too long without cleaning they will choke and stop the flame.

(11) These passages are very difficult to clean if they are allowed to choke tight. Cleaning of these passages about twice a week will prevent trouble.

i. Water heater.—The carrying case for the spare fire unit with each set of range units is designed to be used as a water heater (fig. 35). Two 24-gallon cans may be placed on this heater. The shield, for use on the can being heated, is carried inside of one of the cans. It is placed around the can being heated to hold the heat to the wall of the can.

j. List of replacement parts (figs. 36, 37, and 38).

<i>Number</i>	<i>Name</i>
1.	Cabinet assembly.
84.	Fire unit assembly.
85.	Frame, fire unit assembly.
88.	Strap, anchor, outer, fire unit tank.
88-B.	Rivet, outer anchor strap.
89.	Strap, anchor, inner, fire unit tank.
89-B.	Rivet, inner anchor strap.
90.	Screw, fire unit tank anchor strap.

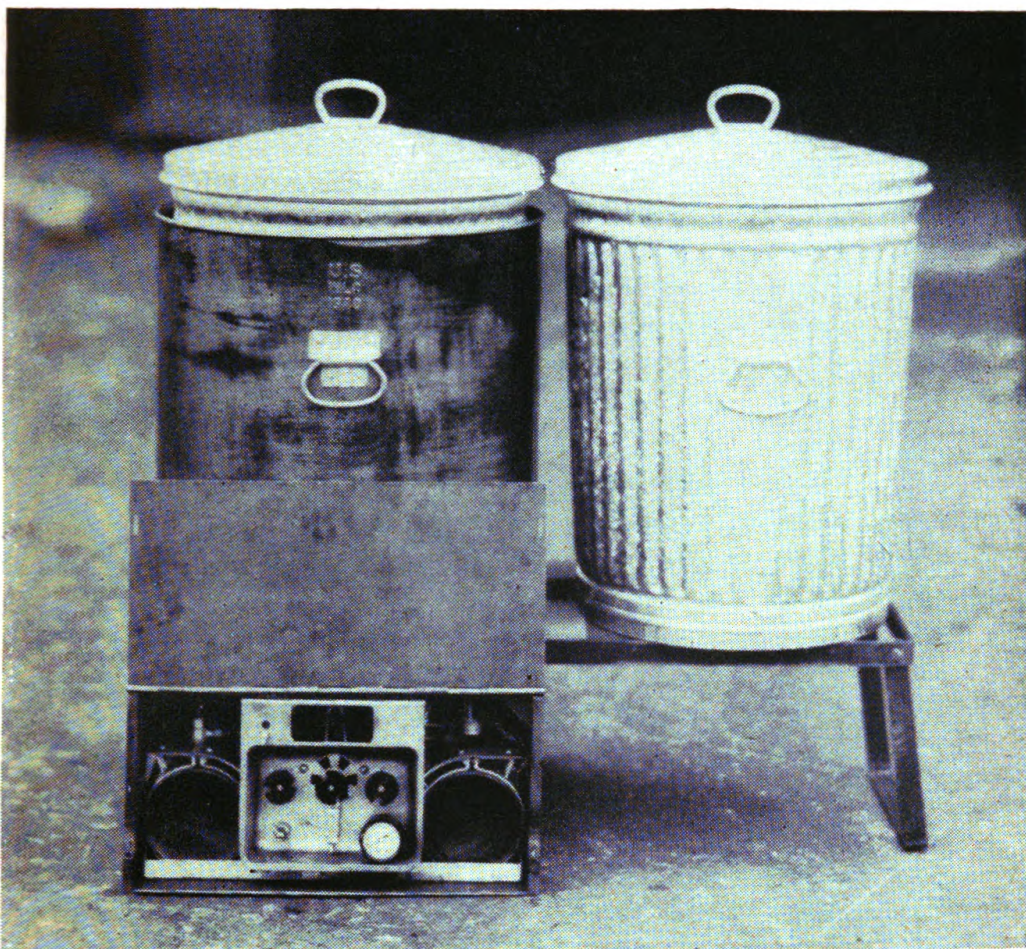

FIGURE 35.—Water heater set up for use (case, can, can cover, and can shield).

<i>Number</i>	<i>Name</i>
93.	Panel, front.
93-B.	Rivet, front panel hinge.
95.	Mirror, front panel.
96.	Screw, front panel mirror.
98.	Screw, set, front panel, $\frac{5}{16}$ by $\frac{5}{8}$ inch.
99.	Tank, fuel.
100.	Shield, fuel tank.
101.	Screw, fuel and air tank shields.
102.	Cap, fuel tank filler tube, old type.
102-B.	Cap, fuel tank filler tube, new type.
103-B.	Valve, fuel tank filler tube cap.
104.	Valve, fuel output, assembly.
105.	Body, fuel output valve.
106.	Tube, uptake, fuel output valve.
107.	Check, safety, fuel output valve.
108.	Tank, air.

<i>Number</i>	<i>Name</i>
109.	Shield, air tank.
110.	Elbow, air output.
116.	Manifold assembly.
117.	Tube, fuel, short.
118.	Tube, fuel and air, long.
119.	Valve, air input assembly.
120.	Body, air input valve.
121.	Stem, air input valve.
122.	Check, air input valve.
123.	Retainer, check, air input valve.
126.	Elbow, gage fitting.
127.	Gage, air pressure.
127-B.	Glass, air pressure gage.
128.	Valve, air and fuel assembly.
129.	Body, air and fuel valve.
130.	Stem, air and fuel valve.
131.	Gland, packing, air, fuel and flame valve.
132.	Packing, air, fuel and flame valve.
133.	Knob, air, fuel and flame valve.
136.	Pin, cotter, air, fuel and flame valve knob.
137.	Valve, flame assembly.
138.	Body, flame valve.
139.	Stem, flame valve.
140.	Jet, fuel, flame valve.
141.	Nut, flame valve.
142.	Shutter, air.
144.	Chamber, mixing.
144-B.	Screw, mixing chamber.
145.	Burner.
146.	Rod, burner control.
147.	Nut, burner.
148.	Generator assembly.
151.	Cap, generator tube.
153.	Disks, filter, in can.
155.	Screw, filter case cap.
156.	Gasket, filter case cap screw.
157.	Yoke, generator.
157-B.	Pin, cotter, generator yoke.
158.	Screw, generator yoke.
159.	Cradle, cook pot.
181.	Box, tool assembly.
187.	Cover, manifold compartment.

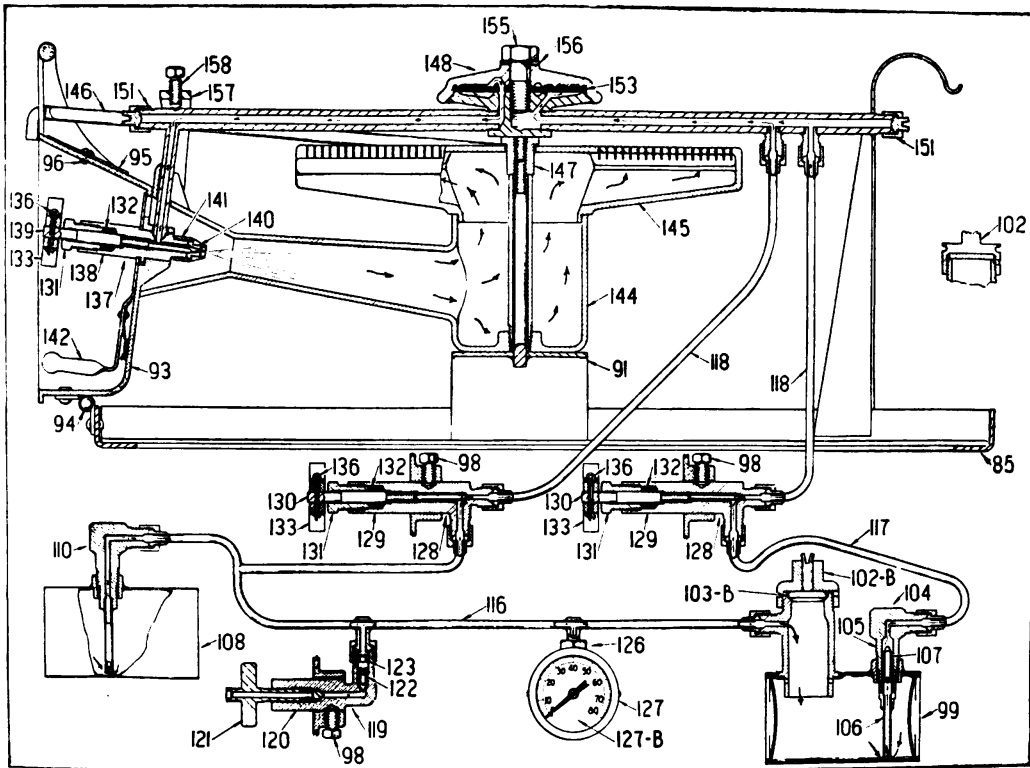

FIGURE 36.—Sectional view of gasoline fire unit.

Number	Name
190.	Pump, air, assembly.
197.	Cup, leather, air pump.
202.	Hose, air pump, with thumb lock and fitting.
205.	Wrench, filter case cap screw.
206.	Wrench, engineers', single head, $\frac{5}{8}$ -inch opening.
207.	Wrench, engineers', single head, $\frac{9}{16}$ -inch opening.
208.	Wrench, setscrew, $\frac{5}{16}$ -inch opening.
209.	Screw driver.
210.	Reamer, fuel jet.
211.	Cleaner, burner slot.
212.	Cleaner, wire, generator.
213.	Brush, steel wire.
214.	Funnel.
215.	Chain, tie-in, right.
216.	Chain, tie-in, left.
218.	Container with graphite grease.
219.	Container for small parts.
220.	Protector, arm, long.
221.	Protector, arm, short.
222.	Pot, cook.

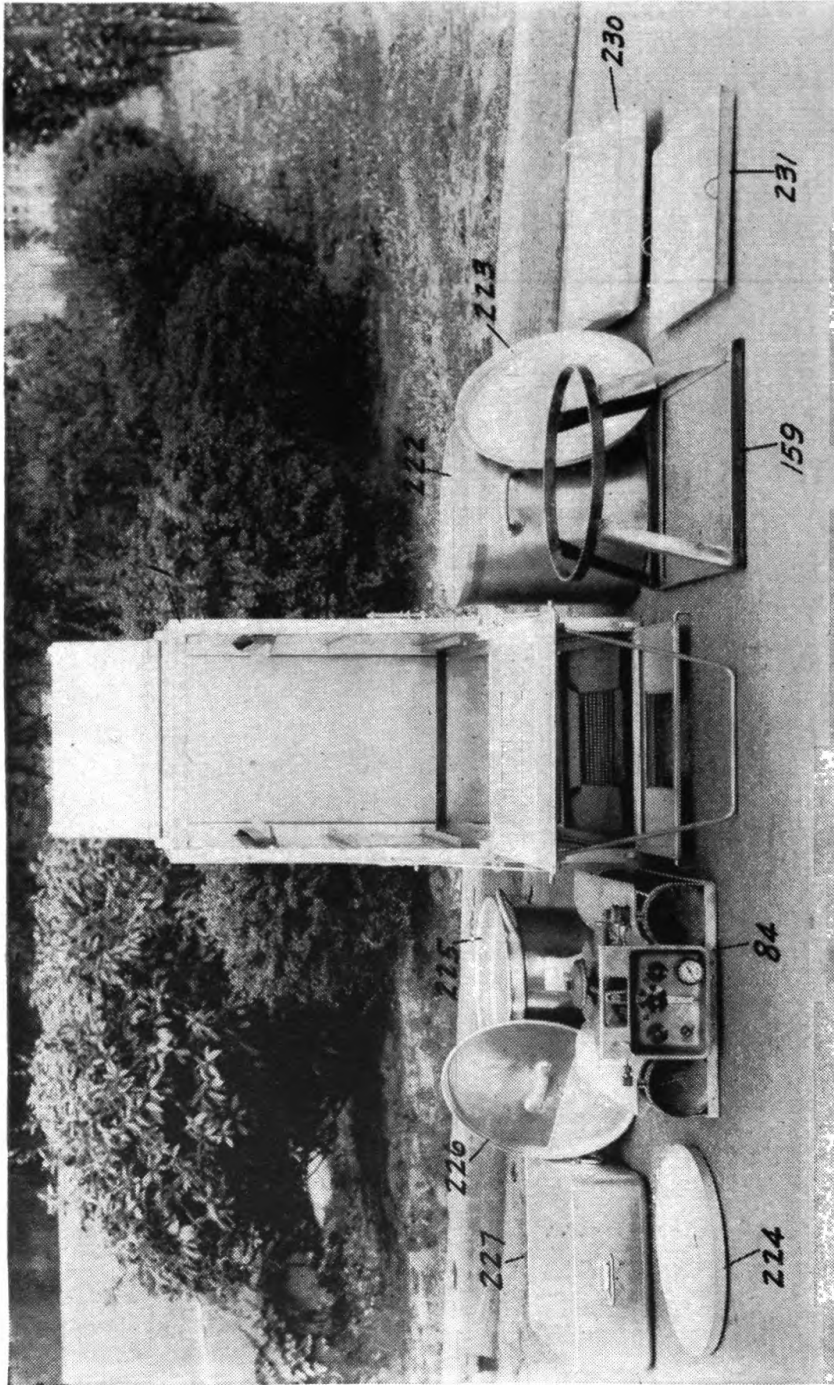

FIGURE 37.—One unit of range, showing cabinet, fire unit, wood burning grate in carrying position, cook pot cradle, and cooking vessels and covers.

THE ARMY COOK

<i>Number</i>	<i>Name</i>
223.	Cover, heavy, cook pot.
224.	Plate, splash.
225.	Insert.
226.	Cover, light, cook pot.
227.	Pan, roasting.
230.	Cover, roasting pan.
231.	Pan, cake.
232.	Can, gasoline.
233.	Hook, hay.

NOTE.—In addition to the above numbered parts the following items are available as replacements:

- Grate, wood burning.
- Case, water heater assembly.
- Can, water heater.
- Cover, water heater can.
- Shield, water heater can.

The gasoline filler tube cap 102, shown on sectional view of gasoline fire unit, is to be ordered for the old type fire unit only. Numbers 102 and 102-B are not interchangeable.

79. Installation of Army field range No. 1 in baggage car.—

a. To install the field range No. 1 in a baggage car as part of an emergency kitchen equipment when kitchen cars are not available, construct a box 6 feet 8 inches long by 5 feet 6 inches wide and about 12 inches deep (inside measurements), with bottom, using 1½- or 2-inch material as available. Line the sides, ends, bottom, and top edge of the box with galvanized iron or zinc. Place box in car on 2 by 4's running lengthwise on one side of the car about 2 feet from the side, giving a 4-inch air space between bottom of box and floor of car. Fill box with dirt to about 2 inches of the top. Place a brick flush with top of dirt at each of the four corners where the range will set. Place range in box, front and oven end close up against end of box, and deep enough in the box so that when oven door is opened it will lie flat on the edge of box. Place boiling plate in box, the end resting on top of angle iron on rear of range. Place brick under each front corner of boiling plate flush with top of the dirt. The Alamo attachments are not used when range No. 1 is installed in the above manner.

b. Fasten range and boiling plate firmly to box by means of strap iron, or two or three strands of telephone or telegraph wires at points shown in figure 39. Fill space between range, boiling plate and side of box with soft mud to prevent heat from escaping. Three and even four field ranges may be installed in a car.

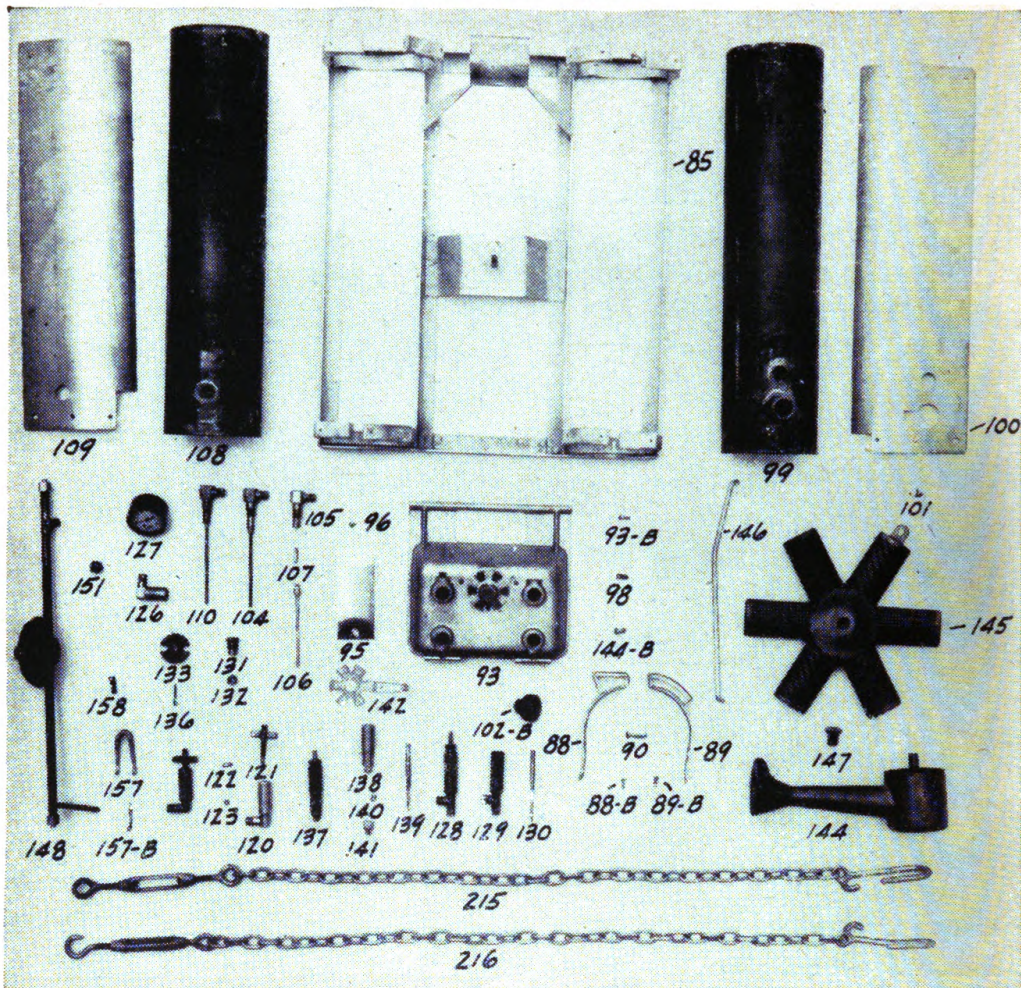

①
FIGURE 38.—Gasoline fire unit parts and tools.

c. Remove one of the top ventilating windows from car; tack tent guards, furnished with each range, over the opening, one on the outside of the car and one on the inside. Carry stovepipe up and out through the opening. End of pipe should extend about 6 inches outside of the opening. Elbow should be placed on end of pipe facing up and wired firmly to car. Wire stovepipe firmly to both sides of car.

d. Box can be held firmly in position on floor of car by nailing 2 by 4 strips around sides and ends of box. This is important and must not be neglected.

e. The following additional equipment to that supplied with each range is necessary: two galvanized iron water cans, two galvanized iron buckets, one stovepipe elbow, and 100 feet of wire.

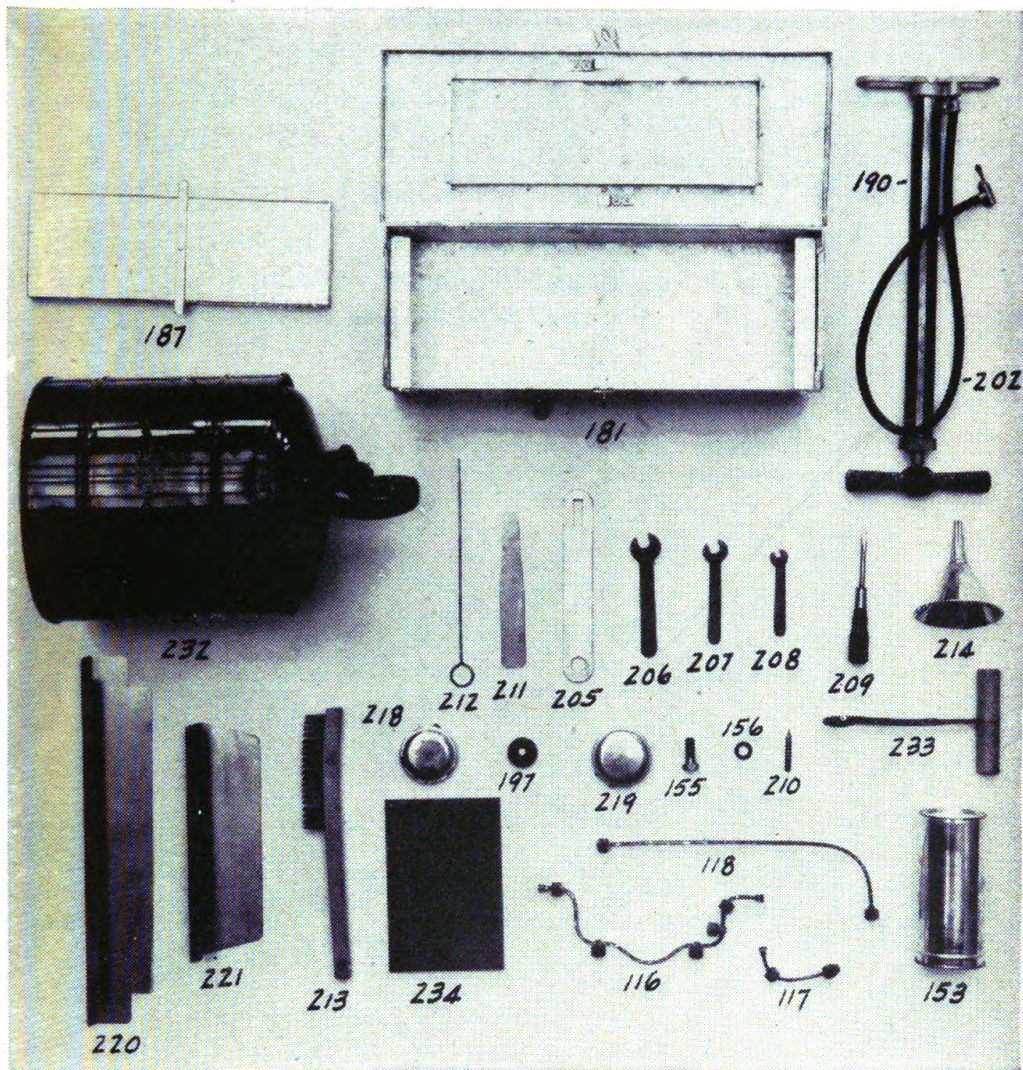

②

FIGURE 38.—Gasoline fire unit parts and tools—Continued.

f. Water cans should be filled on every possible occasion when stops are made.

g. If the equipment is to be set up in a freight car, a hole would have to be cut in the top of the car for the stovepipe, using tent guards as explained in *c* above, to cover this opening.

h. The commanding officer of troops on a train carrying a kitchen car in which a field range has been installed, will issue such orders as may be necessary to insure watchful attention being given the range and the fire in the range, continuously by day or night.

i. Six bricks, placed three to the side, as shown in figure 39 will serve to hold the range securely in position while the car is in motion.

j. A freight car should not be used unless absolutely necessary as the Government will be compelled to pay for repairs necessary to replace the car in proper condition.

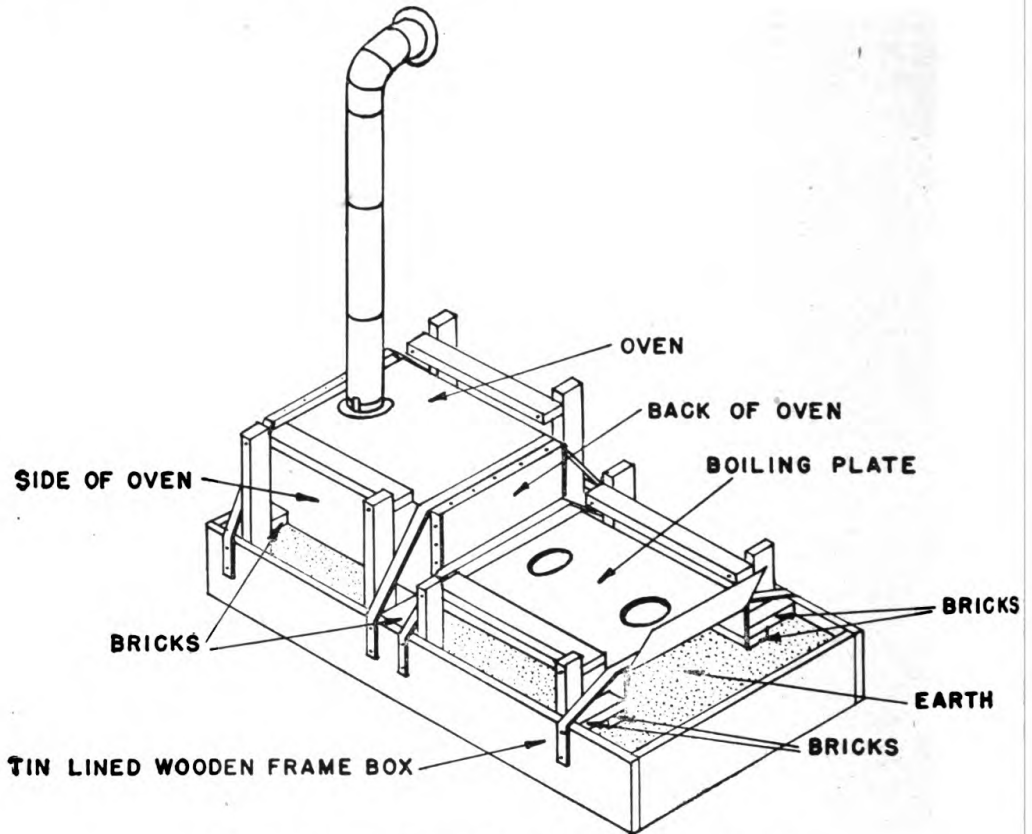

FIGURE 39.—Field range No. 1 installed in baggage car.

80. Installation and use of Army field range M1937 on troop trains.—*a.* The Association of American Railroads considers that that the Army field range M1937 can be safely used for cooking on troop trains when installed and operated in accordance with the instructions below.

b. All range cabinets, securely latched together as a battery, will be placed against the side wall of a baggage car, and secured by stay chains and wooden blocks as indicated in figure 40. The wooden blocks will be secured with 16-penny nails or with lag screws, whichever will result in the least damage to the car floor. The large hook on the outer end of the chain will be run through a link of the chain and will serve as a pull bar against the outer ends of the wooden blocks. In event the car furnished has a wooden interior, the range set will be placed 2 inches from the side of the car.

c. The installation of the range will be made under the supervision of a commissioned officer.

d. One 5-gallon gasoline safety-filling can is furnished as standard equipment with each range set. *Only one* such can of gasoline will be carried in a car, except where the number of range cabinets installed exceeds three, in which event two such cans of gasoline may be carried. Gasoline cans will be placed in individual wood containers secured to the car floor as indicated in figure 41. The wooden containers will be as far removed from the ranges as is practically possible.

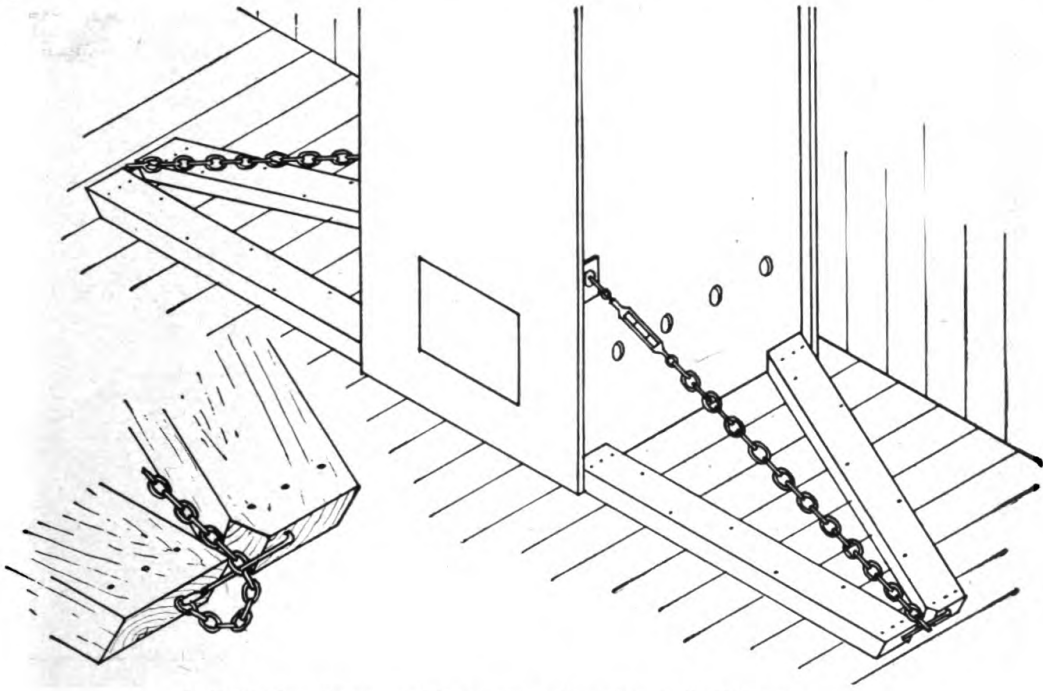

FIGURE 40.—Range cabinet secured to side wall of baggage car.

e. One 1-quart carbon tetrachloride fire extinguisher and one bucket of sand will be provided in the car for each range set of three cabinets.

f. Since the carrying in the car of gasoline in excess of the quantity authorized in paragraph d above is prohibited, arrangements will be made for replenishing the safety cans en route.

g. Fire units will be removed to the other end of the car or outside of the car, if practicable, for refueling. *In no event will units be refueled while there is any fire in the car or while the car is in motion.* The work of refueling fire units will be supervised by a commissioned officer.

h. The installation and use of equipment normally provided for heating water in the field is prohibited on troop trains. The fire unit

normally used for heating water may be carried on troop trains as a spare, provided it is securely fastened to the floor of the car.

i. In order to decrease the fire hazard when ranges are installed in railroad cars with wooden floors, a metal sheet will be placed under the cabinets. This sheet will cover the entire floor area occupied by the range and should extend at least 4 inches beyond the front edge of the cabinets. Twenty-gage metal or heavier is suitable for the purpose.

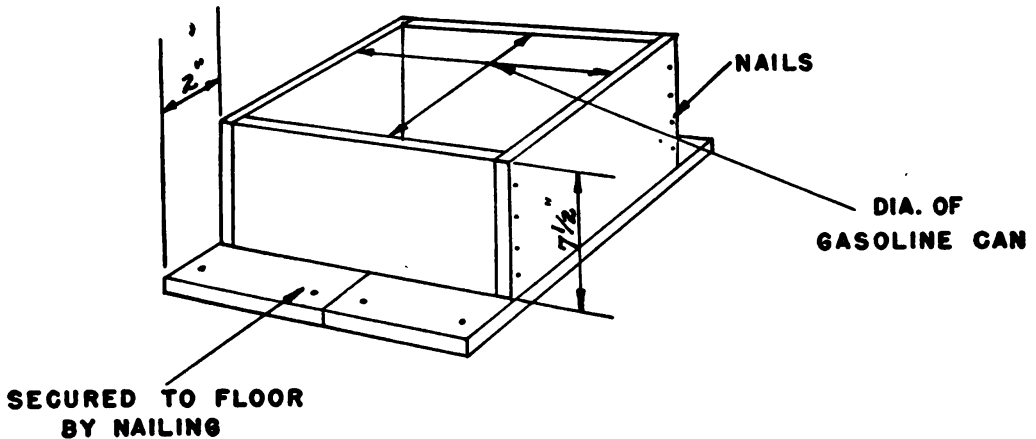

FIGURE 41.—Container for gasoline can.

81. Improvised ice box.—*a.* An ice box is always a great convenience during warm weather and an improvised one may be constructed by simply setting a drygoods box inside of a larger one, preparing the necessary lids, and filling the space between the two boxes (4 to 8 inches) with sawdust, gunny sacks, leaves, grass, hay, straw, or any available nonconducting material. Or even better, use a single box set in the ground and packed around with materials as noted above or with solid dirt.

b. To provide a simple ice box for the field, sink a packing box of suitable size into the ground and prepare a close-fitting cover in two parts, for convenience in handling. It is well to surround the box with heavy paper or with packed straw or grass to prevent dirt from falling in through the cracks. To provide drainage, bore several holes in the bottom of the box, and if practicable, put a quantity of stone or gravel in the bottom of the pit before installing the box. If facilities are at hand, provide a double box (fig. 42). It will be cleaner and on account of the double top the ice will last longer.

82. Garbage.—*a. Source.*—Garbage should accumulate only from uneaten food on the men's mess kits or plates and unavoidable kitchen waste. Both of these sources should be held to a minimum.

Food left on serving platters, in cooking utensils, etc., should be carefully conserved. No edible food should ever go into the garbage if it can possibly be avoided.

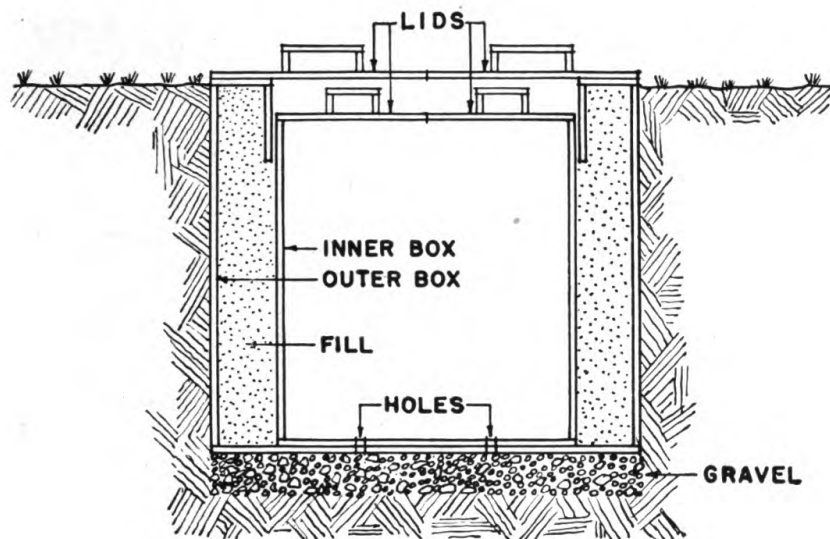

FIGURE 42.—Improvised ice box (double wall).

b. Disposal.—(1) Whenever facilities are not provided for disposing of the kitchen waste, it becomes necessary to dig a slop pit. Open slop pits should be avoided as they attract flies and spread infection. It is necessary, in a camp of other than temporary duration, to strain all dishwater and liquid garbage through a box sieve suitably placed over a pit and burn all solid matter in the range or incinerator. To darken the pit and keep it free from flies, make a board top, tamp edges with dirt, and provide a detachable box sieve with cover (fig. 43). The pit should generally be about 2½

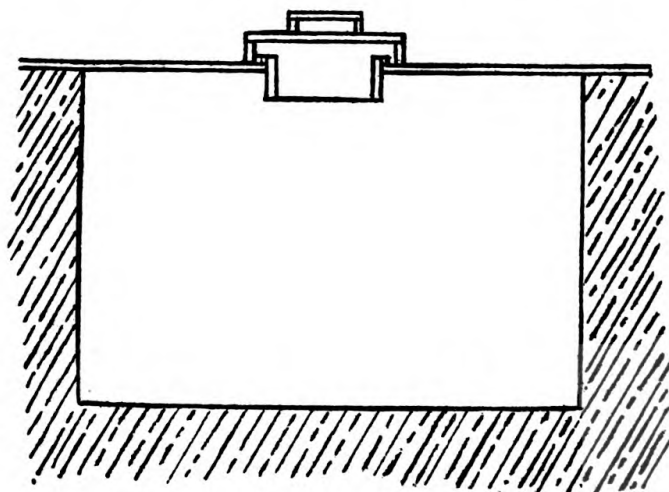

FIGURE 43.—Pit for slops.

feet wide, 5 feet long, and 4 feet deep when dug in clay, and should be filled about half full with large rocks. In more permeable soil the dimensions may be somewhat reduced.

(2) To build a company incinerator, dig two trenches 10 feet long and 10 or 12 inches wide, bisecting each other. At the point of bisection have the trenches 30 inches deep, gradually shallowing from this point to the ends. Fill with rocks until about 18 inches deep at

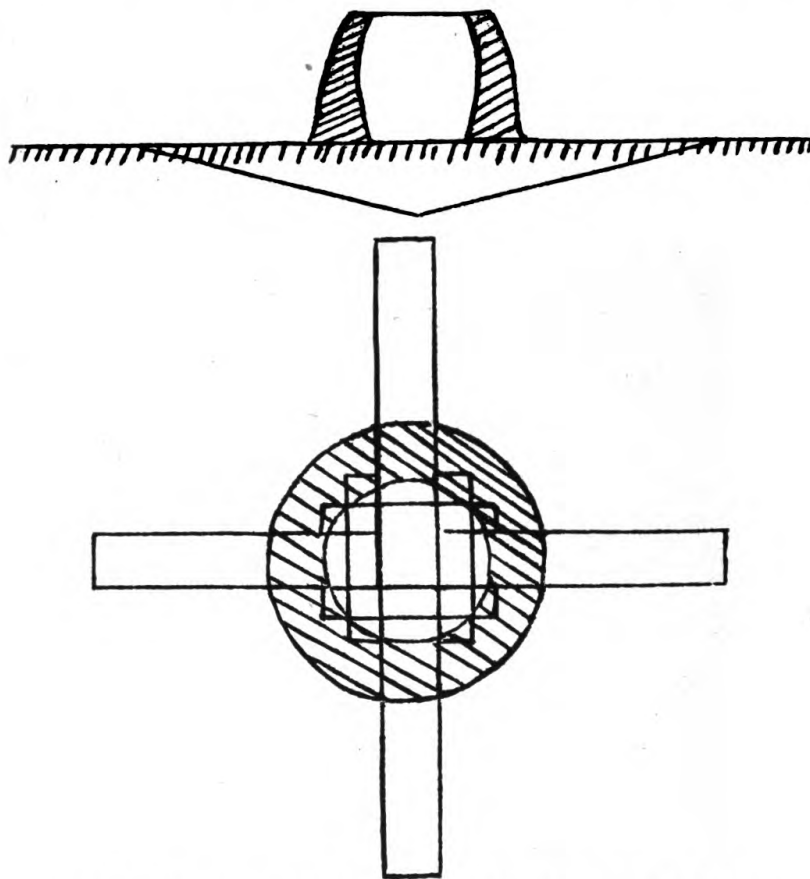

FIGURE 44.—Plan and cross section of company incinerator.

center. Over the place of bisection place four boards to support an ordinary sugar or flour barrel. Around the barrel pile sods of earth packed tightly up to the top. Make a fire in the trench under the barrel, which, upon being burned out, leaves a hard cone (fig. 44). According to the direction of the wind, leave one trench open and plug the other three openings near the cone with boards, turf, or loose soil. This gives a draft of air through the open trench and up through the cone, which acts as a flue. If the soil is full of clay the cone is easily made. If not, it can be done by using sods.

(3) All the garbage produced by a large organization kitchen can be easily disposed of by this means. At the end of each day the ashes and tin cans should be raked out of the fireplace and a fresh fire started in the morning. The fire is kept up by dropping fuel material down the cone, and garbage is fed to it in the same manner. The incinerator is also very satisfactory for disposing of waste water.

CHAPTER 2

RECIPES

SECTION I. General.....	Paragraphs 83-84
II. List of recipes.....	Page 147

SECTION I

GENERAL

Arrangement.....	Paragraph 83
Variation.....	84

83. Arrangement.—*a.* These recipes do not include all the recipes found in other cookbooks due to the fact that all recipes are not suitable for an Army mess. However, a good cook will always be on the alert to discover additional recipes from commercial cookbooks and other sources of dishes which are suitable for an Army mess. In this manual all recipes are based on service for 100 men. The quantity required for a greater or smaller number of men can be easily figured by changing the amount of each ingredient proportionally. For convenience of use and ease in finding, the recipes have been indexed and arranged in groups as follows:

- (1) Breakfast dishes.
- (2) Soups.
- (3) Meat dishes (includes poultry, game, and omelets).
- (4) Gravies and sauces.
- (5) Fish and seafood dishes.
- (6) Vegetable dishes.
- (7) Desserts.
- (8) Sweet-dough products.
- (9) Hot breads.
- (10) Rolls.
- (11) Salads and dressings.
- (12) Beverages.

b. In each group recipes are arranged in alphabetical order. The index should be used as a reminder of the various ways in which

food can be prepared and also of the many varieties of foods and dishes which are usable in a mess.

84. Variation.—The opinions of experienced cooks often vary as to the exact quantities of food required to prepare various dishes for a given number of men. This variation of opinions is due to individual taste or based upon their knowledge of the preference of their particular messes. The recipes in this manual are designed to be a guide for those who do not definitely know the exact quantities required, and these recipes will produce satisfactory results if accurately followed. The quantities shown for 100 men may be successfully modified by an experienced cook and should be so modified by experience where local conditions justify or demand this. The quantity of food consumed by a mess will vary according to the character of duty performed, the number of absentees, the season of the year, and many other causes, and the same mess will require noticeably varying quantities, dependent upon varying conditions of service. Inexperienced cooks should follow the recipes contained herein; experienced cooks may successfully deviate from the recipes under certain conditions, and all cooks should know by experience the proper quantities of food required to satisfy their own messes. This knowledge is acquired by the constant study of these and other recipes and of the preference of the messes which they serve, as evidenced by their consumption or rejection of the dishes offered.

SECTION II

LIST OF RECIPES

BREAKFAST DISHES

Cakes :	Recipe
Buckwheat.....	1
Corn.....	2
Wheat (hot cakes).....	3
Hominy grits, boiled.....	4
Hominy grits, fried.....	5
Milk for breakfast foods.....	6
Mush :	
Corn meal.....	7
Corn meal, fried.....	8
Rolled wheat.....	9
Oatmeal.....	10
Prepared breakfast foods.....	11
Toast, french.....	12
Toast, milk.....	13

SOUPS	Recipe
Barley soup.....	14
Barley and tomato soup.....	15
Bean soup.....	16
Beef soup.....	17
Chicken soup.....	18
Clam chowder.....	19
Codfish chowder.....	20
Corn chowder.....	21
Cream of—	
Cabbage soup.....	22
Celery soup.....	23
Tomato soup.....	24
Green pea soup.....	25
Lentil soup.....	26
Macaroni and tomato soup.....	27
Noodle soup.....	28
Noodles.....	29
Oxtail soup.....	30
Oyster stew.....	31
Potato chowder.....	32
Potato soup.....	33
Purée of—	
Beans.....	34
Carrots.....	35
Green peas.....	36
Green peas and tomatoes.....	37
Lima beans.....	38
Potatoes.....	39
Split peas.....	40
Rice soup.....	41
Split pea soup.....	42
Tomato soup.....	43
Tomato and rice soup.....	44
Vegetable soup.....	45

MEAT DISHES	
Bacon, fried.....	46
Bacon, simmered.....	47
Beef á la mode.....	48
Beef:	
Braised (pot roast).....	49
Braised, with vegetables.....	50
Corned.....	51
Creamed.....	52
Curry of.....	53
Dressing.....	54
Dried, chipped or sliced on toast.....	55
Fricassee.....	56
Fritters.....	57

THE ARMY COOK

MEAT DISHES—continued

	Recipe
Beef—Continued.	
Hash.....	58
Hearts, stuffed.....	59
Loaf.....	60
Potpie.....	61
Pot roast.....	62
Roast.....	63
Rolls.....	64
Simmered.....	65
Spanish.....	66
Turkish.....	67
Beefsteak	68
Hamburg.....	69
Beefsteak and mushrooms	70
Beefsteak and onions	71
Beefsteak potpie	72
Brains	73
Brains and eggs	74
Chicken:	
Creamed.....	75
Fricassee.....	76
Fried.....	77
Roast.....	78
Stew with dumplings.....	79
Dumplings	80
Chili con carne	81
Chuck steak with onions	82
Duck, roast	83
Goose, roast	84
Ham:	
Baked.....	85
Simmered.....	86
Smothered.....	87
Hamburger	88
Hash, chop suey	89
Liver and bacon	99
Meat loaf	91
Mutton:	
Simmered.....	92
Chops.....	93
Potpie.....	94
Stew.....	95
Omelet:	
Plain.....	96
Cheese.....	97
Ham.....	98
Tomato.....	99
Pork:	
Chops.....	100
Cutlets.....	101
Roast.....	102

Public Domain, Google-digitized / http://www.hathitrust.org/access_use#pd-goo-gle

MEAT DISHES—continued

	Recipe
Sausage:	
Bologna, fried.....	103
Pork.....	104
Pork, in blankets.....	105
Frankfurter.....	106
Frankfurter, in blankets.....	107
Short ribs of beef.....	108
Southern creoles.....	109
Spaghetti, Italian style.....	110
Spareribs.....	111
Stew:	
Chop suey.....	112
Pan.....	113
El rancho.....	114
Irish.....	115
Tamales.....	116
Turkey, roast.....	117
Veal cutlets.....	118
Veal, roast.....	119
Yorkshire pudding.....	120

GRAVIES AND SAUCES

Flour batter (for thickening liquids).....	121
Gravy:	
Brown.....	122
Cream.....	123
Giblet.....	124
Stock.....	125
Sauce:	
Barbecue.....	126
Cranberry.....	127
Cream, for codfish.....	128
Plum pudding.....	129
Rhubarb.....	130
Spanish, fish.....	131
Sweet, chocolate.....	132
Sweet, lemon.....	133
Sweet, vanilla.....	134
Tomato.....	135

FISH AND SEA FOOD DISHES

Codfish cakes.....	136
Fish, baked.....	137
Fish, fresh, fried.....	138
Oysters, fried.....	139
Oysters, scalloped.....	140
Salmon cakes.....	141
Salmon hash.....	142

THE ARMY COOK

VEGETABLE DISHES

	Recipe
Asparagus	143
Beans:	
Baked	144
Canned	145
Dry, simmered	146
Lima, green or soaked, canned	147
Lima, dry, simmered	148
String or snap, canned	149
String or snap, fresh	150
Beets:	
Fresh, boiled	151
Canned	152
Harvard	153
Pickled	154
Cabbage	155
Bavarian	156
Boiled	157
Fried	158
Carrots:	
Baked	159
Candied	160
Mashed	161
Corn:	
Canned	162
Fried	163
Fritters	164
Scalloped	165
Eggplant	166
Greens	167
Hominy	168
Macaroni and cheese	169
Onions:	
Boiled	170
Fried	171
Onions and grated cheese	172
Parsnips:	
Baked	173
Mashed	174
Sugared	175
Peas, creamed, canned	176
Peas, green	177
Potatoes:	
Baked	178
Boiled	179
Boiled in jackets	180
Browned	181
Potato cakes	182
Cheesed (au gratin)	183
Creamed	184
French baked	185

VEGETABLE DISHES—continued

Potato Cakes—Continued.	Recipe
French fried	186
Fried (sautéed)	187
German boiled	188
Hashed browned	189
Lyonnaisé	190
Mashed	191
Sweet, baked	192
Sweet, boiled	193
Sweet, candied	194
Sweet, fried	195
Pumpkin, baked	196
Rice:	
Boiled	197
Curried	198
Fried	199
Spanish	200
Steamed	201
Sauerkraut	202
Sauerkraut, how made	203
Squash:	
Baked	204
Canned, baked	205
Mashed	206
Succotash	207
Tomatoes, stewed	208
Turnips:	
Boiled	209
Mashed	210
Left-over	211

DESSERTS

Apples, baked	212
Apple or fruit rolls	213
Apple sauce	214
Apricots, dried, stewed	215
Brown betty	216
Cake:	
Chocolate	217
Corn	218
Eggless	219
Fruit, dark	220
Marble	221
Quick	222
Raised	223
Spice	224
Sponge	225
White	226
Cobbler, apple or fruit	227
Crullers	228

THE ARMY COOK

DESSERTS—continued	Recipe
Custard, egg.....	229
Fritters, oatmeal.....	230
Fruits, dried, stewed.....	231
Gelatin.....	232
Ice cream.....	233
Chocolate.....	234
Coffee.....	235
Ice:	
Lemon.....	236
Orange.....	237
Pineapple.....	238
Icing, boiled, for cakes.....	239
Icing, uncooked, for cakes.....	240
Meringue.....	241
Mincemeat.....	242
Peaches, dried, stewed.....	243
Pie crust.....	244
Pie:	
Apple or fruit.....	245
Banana cream.....	246
Chocolate, meringue.....	247
Coconut cream.....	248
Custard.....	249
Lemon cream.....	250
Mince.....	251
Pumpkin or squash.....	252
Prunes, stewed.....	253
Pudding:	
Apple.....	254
Banana.....	255
Bread, with sauce.....	256
Cornstarch.....	257
Indian, baked.....	258
Plum.....	259
Rice.....	260
Rice and apple.....	261
Sweet potato.....	262
Tapioca.....	263
SWEET DOUGH PRODUCTS	
Basic sweet dough.....	264
Cake, apple.....	265
Cake, coffee.....	266
Doughnuts.....	267
Doughnuts, jelly.....	268
Rolls, cinnamon.....	269
Rolls, parkerhouse.....	270
Stollen.....	271

HOT BREADS

Biscuit:	Recipe
Baking powder.....	272
Cheese.....	273
Sour milk.....	274
Corn bread.....	275
Corn bread (sour milk).....	276
Gingerbread.....	277

ROLLS

Basic dough.....	278
Cinnamon rolls.....	279
Finger rolls.....	280
Pan rolls.....	281
Parkerhouse rolls.....	282
Raisin bread.....	283
Soft bun bread.....	284
Sandwich buns.....	285

SALADS AND DRESSINGS

Apple and celery salad.....	286
Baked bean salad.....	287
Bean, stringless, salad.....	288
Beet salad, pickled.....	289
Cabbage salad.....	290
Cabbage and apple salad.....	291
Celery salad.....	292
Chicken salad.....	293
Cucumber and onion salad.....	294
Lettuce salad.....	295
Piccalilli salad.....	296
Pimento salad.....	297
Potato salad.....	298
Raw vegetable salad.....	299
Salmon salad.....	300
Slaw (coleslaw).....	301
Tomatoes, sliced.....	302
Vegetable salad.....	303
Boiled dressing.....	304
French dressing.....	305
Mayonnaise dressing.....	306
Mustard salad dressing.....	307
Salad dressing, eggless.....	308
Sour cream dressing.....	309
Tomato french dressing.....	310
Thousand island dressing.....	311

BEVERAGES

Cocoa or chocolate.....	312
Coffee, hot.....	313
Lemonade.....	314
Tea, hot and iced.....	315

BREAKFAST DISHES

1. Cakes, buckwheat

8 pounds flour, buckwheat	3 pounds sugar or molasses
4 pounds flours, wheat	1 can milk, evaporated
3 ounces salt	6 quarts water
12 ounces baking powder	24 eggs

Procedure same as for wheat cakes except that no melted fat is added.

NOTE.—When molasses is used it should be mixed with the eggs, water, and milk.

2. Cakes, corn

8 pounds flour	6 quarts boiling water
4 pounds corn meal	2 cans milk, evaporated
12 ounces baking powder	24 eggs, beaten
4 ounces salt	1 pound melted fat
1½ pounds sugar	1 gallon water

Add the corn meal to the boiling water and boil for 5 minutes, cool, then place in mixing bowl. Add the milk and the 1 gallon of water. Sift together the flour, baking powder, salt, and sugar, and mix. Add the beaten eggs and melted fat. Beat well and cook the same as wheat cakes.

3. Cakes, wheat (hot cakes)

12 pounds flour	36 eggs
3 pounds sugar	½ pound fat, melted
4 ounces salt	1 can milk, evaporated
12 ounces baking powder	6 quarts water

Sift together the flour, sugar, salt, and baking powder. Beat the eggs and add to water and evaporated milk. Turn this mixture into the sifted flour mixture and add the melted fat. Then beat into a smooth batter. If the batter seems too thick, add a little more water or milk. Grease a hot griddle iron or clean stove top with bacon rind or clean fat and pour out the batter, a spoonful at a time. Cook until nicely browned on both sides. Serve hot with butter or sirup, or both. Hot cakes should be cooked a few at a time. If all the cakes required for a meal are cooked before starting to serve, the first ones cooked will become tough and leathery.

4. Hominy grits, boiled

9 pounds hominy grits	2 pounds sugar
7 gallons water	2 ounces salt

Bring the salted water to a boil, then add sugar and hominy, and boil for about 20 minutes or until tender. Remove to the back part of the range and let simmer for about 40 minutes. (A double boiler is preferable. One can be made by inserting the boiler containing the hominy into a large boiler.) Serve with butter or sirup.

5. Hominy grits, fried

10 pounds hominy grits, fine 4 ounces salt
7 gallons water

Prepare as in recipe 4. Remove from the boiler, spread about 1 inch deep in well-greased pan, and allow to cool. Cut in pieces about 2 inches square, roll in flour, and fry in deep fat. Serve hot with sirup or butter.

6. Milk for breakfast foods

15 cans milk, evaporated 1 ounce salt
2 pounds sugar

Add sufficient water to make 7½ gallons. Whip well for a few minutes. One ounce vanilla or lemon extract may be added if desired. This recipe will produce a satisfactory substitute when fresh milk is not available.

7. Mush, corn meal

10 pounds corn meal, white or yellow 7 gallons water
3 pounds sugar 1½ ounces salt

Bring the salted water to a boil, then add the sugar and corn meal, meanwhile whipping briskly to prevent lumping. Cook for about 20 minutes and then allow to stand about the same length of time where it will remain hot. Place in vegetable dishes and serve with fresh milk or diluted evaporated milk.

8. Mush, corn meal, fried

12 pounds corn meal 3 ounces salt
7 gallons water 2 pounds sugar

Prepare in the same manner as corn meal mush. Pour the mush into a well-greased bakepan to a depth of about 1 inch, allow to cool, cut into pieces about 2 inches square, dip in a flour batter, and fry in a deep fat. Serve hot with butter and sirup.

This preparation may be improved by dipping each piece in an egg batter before rolling in the flour.

9. Mush, rolled wheat

Prepare in the same manner as oatmeal (recipe 10), using 9 pounds rolled wheat instead of 9 pounds of oatmeal.

10. Oatmeal

9 pounds oatmeal	2 ounces salt
½ pound sugar	8 gallons water

Bring the salted water to a boil, whip the oatmeal in slowly, adding sugar, and boil for 5 minutes. Let simmer 30 minutes and serve with milk and sugar.

11. Prepared breakfast foods

Follow the directions given on the packages.

12. Toast, french

30 pounds bread, dry	36 eggs
5 cans milk, evaporated	1 pound flour
7 pints water	2 ounces salt

Slice the bread ½ inch thick (be careful not to cut bread too thick). Mix milk, water, eggs, salt, and flour into a batter. Dip slices in the batter and fry in deep fat or on a griddle. Serve hot with butter or sirup, or both.

13. Toast, milk

20 pounds bread	4 gallons milk, or 16 cans milk, evaporated, and 15 pints water
4 pounds sugar	

Slices of left-over bread may be used. Place the bread in a large bakepan (not more than one-third full) and brown in a 15-count oven. Serve in vegetable dishes with hot sweetened milk poured over it.

SOUPS

14. Barley soup

7 gallons beef stock	2 pounds onions, chopped
3 pounds barley, pearled	Salt and pepper to taste

Thoroughly mix all ingredients and boil for 1 hour. Ten minutes before serving add enough beef stock to make 10 gallons of soup. Season to taste with salt and pepper.

15. Barley and tomato soup

7 gallons beef stock	2 pounds bacon, diced
5 pounds barley	Salt and pepper to taste
8 pounds tomatoes (fresh or canned)	

Thoroughly mix all ingredients and boil for 1 hour. If fresh tomatoes are used, they should first be stewed and pressed through a colander. Ten minutes before serving, add enough beef stock to make 10 gallons of soup. Season to taste with salt and pepper.

16. Bean soup

3 pounds beans, dry	1½ pounds bacon, diced and browned
7 gallons water or beef stock	2 cans tomatoes (No. 2½ or No. 3 cans)
10 pounds soup bone	Salt and pepper to taste

Thoroughly clean and wash the beans. Place them and the soup bone in the beef stock and allow to simmer for about 5 hours, or until the beans have gone to pieces and will pass through a colander. Ten minutes before serving add the tomatoes, the diced and browned bacon, and enough beef stock to make 10 gallons of soup. Thicken with a flour batter and season to taste with salt and pepper. Serve hot with crackers or croutons.

17. Beef soup

7 gallons beef stock	2 pounds rice, if desired
5 pounds beef (shank, neck, etc.)	1 bunch parsley, if desired
2 cans tomatoes (No. 3 cans)	Salt and pepper to taste

This soup may be made to best advantage on days when simmered beef is served. After simmering the beef until done, take it out and skim off the grease. Dice the beef very fine and add the stock and tomatoes to the water in which the beef was boiled; if desired, a little rice may be added. Ten minutes before serving, add enough beef stock to make 10 gallons of soup. Season to taste with salt and pepper and serve hot. Sprinkle with chopped parsley.

18. Chicken soup

7 gallons beef stock	2 pounds rice
17 pounds chicken scraps (bones, wing tips, necks, legs, etc.)	6 ounces parsley, chopped fine
	Salt and pepper to taste

Simmer the chicken scraps until well done. Remove the bones and place them in the beef stock, then simmer for 1 hour. Remove the bones and strain the stock. Dice the chicken very fine and place in a boiler with the strained stock and add the rice and boil for 30 minutes. Ten minutes before serving, add enough beef stock to make 10 gallons of soup. Sprinkle with chopped parsley.

NOTE.—Chicken soup should be made only when chicken is being served in one of the following forms: roasted, stewed, or fricasseed. It is not economical to buy chicken for the sole purpose of making soup. On days when chicken is

being served there are ample scrap meat and bone from wing tips, necks, legs, etc., to make a delicious chicken soup.

19. Clam chowder

6 quarts clams, husked, diced	2 pounds onions, chopped, browned
2 pounds bacon, diced and browned	2 pounds flour
12 pounds potatoes, diced, raw	Salt and pepper to taste
7 gallons beef stock	

Boil the potatoes, clams, bacon, and onions in the beef stock until well done. If fresh clams are used, wash thoroughly to remove sand. Thicken slightly with a flour batter and serve hot. Season to taste with salt and pepper and add enough beef stock 10 minutes before serving to make 10 gallons.

20. Codfish chowder

9 pounds codfish, salt, shredded	2 pounds bread
2 pounds bacon, diced	4 cans milk, evaporated
2 pounds onions, chopped	7 gallons beef stock
6 pounds potatoes, diced, raw	Salt and pepper to taste

Brown the bacon and onions in a bakepan, then transfer to a boiler and add the potatoes, codfish, and beef stock. Boil until done, about 20 minutes. Add enough beef stock 10 minutes before serving to make 10 gallons. Toast sliced bread (preferably dried-out bread) in the oven and add it, after dicing, to the chowder when the potatoes are done. Then add the milk and season to taste with salt and pepper.

21. Corn chowder

5 cans corn (No. 2 cans)	8 gallons beef stock
2 pounds bacon, diced	4 cans milk, evaporated
2 pounds onions	2 pounds bread, diced
6 pounds potatoes, diced	Salt and pepper to taste

Brown the bacon and onions in a bakepan, then transfer to a boiler and add the potatoes and beef stock. Boil until done (about 20 minutes). Add enough beef stock 10 minutes before serving to make 10 gallons. Toast sliced bread (preferably dried-out bread) in the oven and add it to the chowder after the potatoes are done. Add the milk and corn but do not allow to boil. Season to taste with salt and pepper.

22. Cream of cabbage soup

10 pounds cabbage, chopped fine	2 pounds fat, butter preferred
7 gallons beef stock	1 pound flour, browned in the fat
4 cans milk, evaporated	Salt and pepper to taste

Boil the cabbage about 15 minutes, add the beef stock, thicken with the flour, and season to taste with pepper, salt, and celery salt. Add the milk. Add enough beef stock 10 minutes before serving to make 10 gallons.

23. Cream of celery soup

7 pounds celery, diced fine	2 pounds flour, browned in fat
7 gallons beef stock	4 cans milk, evaporated
2 pounds fat, butter preferred	Salt and pepper to taste

Add the celery to the beef stock and boil about 1 hour. Season to taste with pepper, celery salt, and salt. Thicken with batter made of the fat and flour, and just before serving add the milk. Add enough beef stock 10 minutes before serving to make 10 gallons.

24. Cream of tomato soup

7 gallons beef stock	2 pounds fat, butter preferred
4 cans tomatoes (No. 3 cans)	2 pounds flour, browned in fat
4 cans milk, evaporated	Salt and pepper to taste

Add the tomatoes to the stock and bring to a boil. Break up the tomatoes. Season to taste with celery salt, mustard, salt, and pepper. Thicken slightly with the flour, and add the milk and a pinch of soda. Add enough beef stock 10 minutes before serving to make 10 gallons.

25. Green pea soup

10 cans green peas (No. 2 cans) or 12 pounds fresh shelled peas	7 gallons beef stock Salt and pepper to taste
--	--

If canned peas are used, boil for 10 minutes in the beef stock. If fresh peas are used, boil in beef stock until well done. Add enough beef stock 10 minutes before serving to make 10 gallons.

26. Lentil soup

Prepared in the same manner as bean soup, substituting lentils for beans.

27. Macaroni and tomato soup

3 pounds macaroni	5 cans tomatoes (No. 3 cans) or equivalent fresh tomatoes
7 gallons beef stock	Salt and pepper to taste
2 pounds onions, chopped	
2 pounds bacon, diced	

Break the macaroni in pieces about 1 inch long. Add macaroni, onions, and bacon to boiling beef stock and boil for 40 minutes, seasoning to taste with salt and pepper. Add tomatoes and boil a few minutes. Break up the tomatoes. Add enough beef stock 10 minutes before serving to make 10 gallons.

28. Noodle soup

7 gallons beef stock Salt and pepper to taste
5 pounds noodles

Boil noodles 40 minutes in the seasoned soup stock. Add enough beef stock 10 minutes before serving to make 10 gallons.

29. Noodles

3 pounds flour 9 eggs
1½ ounces salt Milk or water to make a stiff dough

To prepare noodles, sift one-half ounce of salt with each pound of flour, break three eggs into the sifted mixture, and mix with milk and water until a stiff dough is formed. Roll the dough out until it is about one-eighth inch thick, sprinkle a little flour over it, and roll it up. Cut slices from the end of the roll about one-eighth to one-fourth inch wide and spread on a board or cloth in the sun to dry.

30. Oxtail soup

12 pounds oxtails 4 pounds onions, diced
7 gallons beef stock Salt and pepper to taste
4 pounds carrots, diced

Cut the oxtails into small pieces (about 1 inch long), wash, drain, sprinkle with salt and pepper, dredge with flour, and brown in fat or bacon drippings in a pan on top of the stove. Add to the stock with the carrots and onions, and simmer until the meat is tender. If desired, the soup may be thickened with a flour batter. Just before serving add sufficient stock to make 10 gallons of soup.

31. Oyster stew

10 quarts oysters, fresh, or 20 cans 5 cans milk, evaporated
oysters (No. 2 cans) Salt and pepper to taste
7 gallons beef stock

Drain the liquor from the oysters. Add flour to the liquor from the oysters to make a thin batter. Add the batter to the stock and bring to a boil. Season. Add the oysters and simmer 5 minutes. Add enough beef stock 10 minutes before serving to make 10 gallons.

32. Potato chowder

Prepare in same manner as corn chowder (recipe 21), using 10 pounds of potatoes in place of corn.

33. Potato soup

10 pounds potatoes, diced	2 pounds fat, butter preferred
7 gallons beef stock	1 pound flour, browned in fat
2 pounds onions, chopped and browned	Salt and pepper to taste
2 cans milk, evaporated	

Boil the potatoes in the stock until well done, then pass through a colander and bring to a boil again. Thicken with the flour batter. Add the chopped onions and evaporated milk. Add enough beef stock 10 minutes before serving to make 10 gallons.

34. Purée of beans

5 pounds dry beans	2 pounds fat, butter preferred
7 gallons beef stock	2 pounds flour, browned in fat
1 pound bacon, diced and browned	Salt and pepper to taste

Place the beans, bacon, and stock in the boiler, and let simmer over night, or until the beans are thoroughly broken to pieces. Pass through a colander, replace in boiler, and add a batter made of the flour and fat. Season. Allow to simmer at least 1 hour before serving. Ten minutes before serving add enough beef stock to make 10 gallons of soup.

35. Purée of carrots

Prepare in the same manner as purée of beans (recipe 34), using 17 pounds of diced carrots braised or fried in a little fat until brown, instead of 5 pounds of beans, and simmer about 2 hours or until carrots are well done.

36. Purée of green peas

Prepare in the same manner as purée of beans (recipe 34), using 5 pounds of green peas instead of 5 pounds of beans. Only about 1 hour's simmering is required.

37. Purée of green peas and tomatoes

Prepare in the same manner as purée of green peas (recipe 36), using four No. 3 cans tomatoes (or the equivalent in fresh tomatoes), and 6 pounds of green peas.

38. Purée of lima beans

Prepare in the same manner as purée of beans (recipe 34), using 5 pounds of dry lima beans instead of 5 pounds of dry beans. Two and one-half cans of evaporated milk or 3 quarts of fresh milk added just before serving greatly improve the flavor.

39. Purée of potatoes

10 pounds potatoes, diced fine	2 pounds fat, butter preferred
7 gallons beef stock	1 pound flour, browned in fat
2 pounds bacon, diced and browned	Salt and pepper to taste

Add the potatoes and bacon to the cold stock and boil until potatoes are completely broken to pieces, seasoning to taste. A stalk of fresh celery or a little celery salt may be used as additional seasoning. Thicken slightly with the flour batter. Add enough beef stock 10 minutes before serving to make 10 gallons.

40. Purée of split peas

Prepare in the same manner as purée of beans (recipe 34), using 5 pounds of split dried peas instead of 5 pounds of beans.

41. Rice soup

3 pounds rice	2 pounds bacon diced and browned
7 gallons beef stock	Salt and pepper to taste
1 pound onions, chopped and browned	

Wash the rice and add it to the bacon, onions, and cold stock, and boil for 1 hour.

42. Split pea soup

7½ pounds split peas	7 gallons beef stock
2 pounds bacon, diced and browned, or ham bones or bacon rind	Salt and pepper to taste

Add the peas and bacon to the cold stock and let simmer for 5 hours. Add enough beef stock 10 minutes before serving to make 10 gallons.

43. Tomato soup

12 pounds tomatoes, fresh, or 6 cans tomatoes (No. 3 cans)	2 pounds flour
5 gallons beef stock	1 pound sugar
2 pounds bacon	Salt and pepper to taste

Place the tomatoes and bacon in the stock and boil for 1½ hours. Remove the bacon and press the soup through a colander to separate the skins and seeds of the tomatoes. Replace on the range and thicken with a flour batter. Color lightly with caramelized sugar. Add enough beef stock 10 minutes before serving to make 10 gallons.

44. Tomato and rice soup

3 cans tomatoes (No. 3 cans) or 6 pounds fresh tomatoes	7 gallons beef stock
2 pounds rice	Salt and pepper to taste

Chop the tomatoes thoroughly and mix all ingredients. Season to taste, adding a small piece of garlic. Boil for 1 or 2 hours. Add enough beef stock 10 minutes before serving to make 10 gallons.

45. Vegetable soup

2 pounds cabbage	1 pound rice
1 pound onions	7 gallons beef stock
2 pounds potatoes	2 pounds celery
2 cans tomatoes (No. 3 cans) or 4 pounds fresh tomatoes	Parsley, chopped
	Salt and pepper to taste

Chop and thoroughly mix all ingredients. Start in cold water. Boil for 1 hour or more. Add enough beef stock 10 minutes before serving to make 10 gallons. Parsley may be added as a garnish just before serving. Many other vegetables may be substituted for those indicated.

MEAT DISHES (includes poultry, game and omelets)

46. Bacon, fried

22 pounds bacon, issue, or 24 pounds bacon, breakfast

Cut about five slices to the inch. If dry salt issue bacon is used, place in a bakepan containing boiling water, boil for 5 minutes, then drain off water. Fry on a hot range or in a quick oven. Drain off excess fat and stir occasionally so that all the bacon is thoroughly cooked. If served with eggs or hot cakes, etc., 10 pounds bacon are sufficient.

47. Bacon, simmered

22 pounds bacon, issue

Cut into pieces weighing about 5 pounds each. Wash thoroughly and place in cold water. Simmer for 2 hours. Slice and serve.

48. Beef à la mode

35 pounds beef, fresh (from less tender cut)	2 pounds carrots, diced
2 pounds bacon or pork	6 pickles, issue, large
1 pound flour, browned in ½ pound butter or other fat	3 cans tomatoes (No. 3 cans)
5 gallons beef stock	1 clove garlic, chopped fine
	Salt and pepper to taste

Cut the beef into pieces weighing about 5 pounds each and rub with salt and pepper. Cut the bacon (or pork) into strips about the thickness of the little finger and the length of the pieces of beef, using a narrow-bladed knife. Cut four equally spaced slits in each piece of

Public Domain, Google-digitized / http://www.natml.usc.org/access_use#_pb-gooogle

the beef, parallel with the grain. Insert in each slit one piece of bacon, rolled in garlic and cayenne pepper, and one slice of pickle. Brown meat on all sides in hot fat. Make a gravy of flour, fat, tomatoes, and beef stock. Put the meat in a pan, pour the gravy over it, and place the carrots around it. Cook in a slow oven (200°-250° F.—20 count) for about 3 hours or until well done. Remove meat from oven, slice across the grain, replace in the gravy and cook a little longer, or slice and place on a platter with the gravy poured over it. Serve with hot gravy. The gravy should be very spicy, therefore, season it well with garlic, bay leaves, or Worcestershire sauce.

49. Beef, braised (pot roast)

55 pounds beef, fresh (from less tender cut)	1 pint vinegar
8 pounds onions, chopped	Salt and pepper to taste

Cut the beef into pieces weighing about 5 pounds each. Wipe with a damp cloth. Sear until well browned on all sides. Season. Place in a large dutch oven or camp kettle or any covered utensil. A heavy utensil is best. Add the chopped onions and vinegar. If the meat is well covered with fat, basting is not necessary. If the beef is lacking in fat, it is a good practice to lard with strips of fat or place a layer of fat on top. About 2 pounds of fat pork or bacon are required for this. This added fat improves the flavor, melts, and bastes the meat. Cook covered, in a slow oven (200°-250° F.) or on top of stove until tender. This will require 2 to 5 hours, depending on tenderness of beef used. The beef should be turned three or four times while cooking. When done, remove from utensil and slice. The pot roast may be served in either of two ways: Make a thick gravy in the utensil in which the beef was roasted and pour this gravy over the sliced beef on platters, or make a gravy of the desired thickness and serve separately.

50. Beef, braised, with vegetables

40 pounds beef, chuck roast (not boned)	8 pounds turnips, sliced
8 pounds carrots, sliced	1 clove garlic, chopped fine
8 pounds onions, sliced	3 pounds flour
8 pounds celery, cut in bits	Salt and pepper to taste

Cut the meat into pieces weighing about 5 pounds each, wipe it with damp cheesecloth, and roll in flour. Place vegetables in sufficient salted cold water to barely cover them and boil until soft, then rub them through a colander or coarse strainer. Sear the meat on all sides. After the meat is seared, transfer it to a kettle or kettles.

If the beef is lean (lacking in fat), it is well to cut about 2 pounds of fat pork into strips, or use sliced bacon, and lay on top of the beef. This keeps the roast basted. Pour the vegetables and their liquid over the meat, together with any preferred seasoning. Cover tightly and let it simmer slowly for 4 or 5 hours, turning twice. After the meat is cooked, remove from kettle. Thicken the liquid remaining in the kettle by adding flour, and pour it over the meat.

51. Beef, corned

50 pounds corned beef

Wash the meat in warm water and, if it has been in brine until too salty, cover it with cold water and bring slowly to a boil. Drain off the water, cover again with fresh cold water, and reheat. As soon as the liquid bubbles, reduce the heat, add a few whole peppers, and continue cooking slowly (always below the boiling point) for 2 or 3 hours, according to quality and quantity of beef, until the meat is tender. Keep the meat closely covered during the cooking process, and turn it when partly done, adding hot water from time to time so as to keep it completely covered. Carrots, parsnips, and potatoes may be added during the cooking process, if desired.

52. Beef, creamed

20 pounds coarse ground beef
1 pound lard or butter
2 pounds flour

8 cans milk, evaporated
2 gallons beef stock or water

Braise the meat. Make a gravy in a separate pan as follows: Melt the lard, add the flour, stirring constantly until thoroughly blended and browned. Stir in the liquid, a little at first, then enough to thin the mixture, and finally the remainder. Season to taste. Pour the gravy over the ground meat and simmer until the meat is tender.

53. Beef, curry of

45 pounds beef, fresh
1 pound flour

2 ounces curry powder
Salt and pepper to taste

Cut the beef into 1-inch cubes and place in a bakepan. Cover with cold beef stock or water and season to taste with curry powder (usually about 2 ounces of curry powder is used). Cook in a slow oven (200°-250° F.—18 to 20 counts) about 3 hours. When nearly done thicken slightly with a flour batter. Serve hot.

54. Beef dressing

10 pounds beef scraps of any kind	1 gallon beef stock
14 pounds bread	1 ounce sage
2 pounds onions, chopped	Salt and pepper to taste

Run the meat scraps through a chopper, soak the bread in cold water and remove excess water by squeezing. Mix the meat and bread with the onions, season with sage to taste, add sufficient beef stock to make about the same consistency as hash, and spread 2 or 3 inches deep over the bottom of a well-greased pan. Spread a little grease over the top and bake for 40 minutes in a medium oven (325°-400° F.—12 to 16 counts). Serve hot with meat and gravy.

Do not leave on the stove as this causes the dressing to become dry and hard.

55. Beef, dried, chipped or sliced on toast

7 pounds chipped or sliced dried beef	2 bunches parsley, chopped fine
2 pounds fat, butter preferred	½ ounce pepper
1 pound flour, brown in fat	4 gallons beef stock
4 cans milk, evaporated	130 slices bread (about 12 pounds)

Melt the fat in the pan and add the flour. Cook a few minutes to brown the flour. Add the milk and beef stock, stirring constantly to prevent lumping. Add the dried beef and cook 5 minutes. Add the parsley and pepper. Serve hot on toast.

56. Beef fricassee

45 pounds beef, fresh (from less tender cut)	3 pounds fat, butter preferred
2 pounds onions	3 gallons beef stock
1 pound flour	Salt and pepper to taste

Heat the fat in a bakepan. Add the beef diced into 1-inch cubes, and onions. Brown on top of the range or in a quick oven (400°-450° F.—9 to 12 counts) for about 20 minutes. Sift in the dry flour and continue cooking for about 5 minutes. Add sufficient beef stock to nearly cover the meat and mix thoroughly. Cook on top of the stove or in a slow oven (200°-250° F.—18 to 20 counts) until well done.

57. Beef fritters

25 pounds cooked beef	1 pound flour
8 pounds bread	Salt and pepper to taste
3 pounds onions, minced	

Soak the bread and remove the excess water by squeezing with the hands. Grind the meat fine and add the bread and minced onions

and mix all together. Mold into cakes of about 3 ounces each, roll in flour, and fry in deep fat until brown. Serve hot with tomato sauce. The fritters may be improved by dipping in egg batter before rolling in flour.

58. Beef hash

15 pounds potatoes	10 quarts beef stock
5 pounds onions	1 clove garlic
25 pounds meat scraps, fresh or cooked	Salt and pepper to taste

Chop the ingredients fine and add the beef stock until the mixture is of the consistency of ordinary mush and place about 3 inches deep in a well-greased pan. Smooth the top and grease lightly. Bake in a quick oven (400°-450° F.—9 to 12 counts) for 1½ hours, or until done. Scraps of beef or pork, or a mixture of both, or corned beef may be used for making hash.

59. Beef hearts, stuffed

32 pounds beef hearts	1 gallon beef stock
10 pounds bread crumbs	2 pounds bacon, sliced
3 pounds onions	Salt and pepper to taste
½ pound fat	

Wash and clean the hearts and allow to drain. Chop and brown the onions. Soak the bread crumbs, squeeze out excess water, and mix with the onions. Season to taste with thyme and stuff the holes in the hearts with the dressing. Place the hearts in a bakepan with a slice of bacon on top of each, and make in a medium (325°-400° F.—12 to 16 counts) oven. After the hearts have become nicely browned, the temperature of the oven should be reduced. Cook until done, allowing 3 to 3½ hours. Slice thin and serve.

60. Beef loaf

40 pounds beef, fresh	25 eggs, beaten
5 pounds bacon	1 pound flour
2 pounds onions	2 or 3 quarts beef stock
1 clove garlic	Salt and pepper to taste

Grind the meat, onions, and garlic together. Add beaten eggs, salt, and pepper. Mix well. Make into loaves about 4 inches wide by 3 inches high and as long as the pan is wide. A loaf of this shape can be cut into pieces of attractive size and about the proper size for the individual, and the pieces will hold their shape. Then make a batter of flour and beef stock, rubbing this over the loaves. Place in the oven (200°-250° F.—18 to 20 counts) and make for about 1½ hours.

A slice of bacon may be placed on the top of each loaf to improve the flavor. Serve hot with gravy.

Beef loaf may be served with tomato sauce, if desired.

61. Beef potpie

35 pounds beef, fresh or left-over	5 pounds turnips
17 pounds potatoes	5 pounds carrots
2 cans tomatoes (No. 10 cans) or equivalent fresh tomatoes	1 clove garlic
5 pounds onions	1 pound flour
	Salt and pepper to taste

Cut the beef into 1-inch cubes, place in cold water, and bring quickly to a simmer. Add turnips and carrots cut in 1-inch cubes and simmer until these are nearly done. Add cut potatoes, chopped garlic, onions cut in 1-inch cubes, and the tomatoes, and finish cooking. Thicken slightly with flour batter and cover with raw biscuits. Serve as soon as the biscuits are done.

62. Beef, pot roast

55 pounds beef, fresh	Salt and pepper to taste
2 pounds onions	3 pounds flour

Use meat from the chuck, brisket, shoulder, or any other less tender part of the carcass and cut into 5-pound pieces. Make a gravy of beef stock and flour batter. Season well with salt and pepper. Put the meat and onions in the gravy and cook in a slow oven (200°-250° F.—18 to 20 counts) until tender. The gravy should cover the meat in the pan about one-half inch as in the preparation of beef à la mode. Slice the meat and serve on a platter with hot gravy poured over it. Serve with dumplings.

63. Beef, roast

55 pounds beef, fresh

This recipe is for cooking the tender cuts of beef. The less tender cuts should be braised, if a roast is desired.

Cut the beef into pieces about 5 pounds each and wipe with a damp cloth. Sear until all sides are well browned. If the beef is lean (lacking in fat), it is well to lard it with about 2 pounds of fat pork cut into strips, or lay these strips over the top. Sliced bacon may be used. This improves flavor and bastes the beef while roasting. Place in pan with fat side up. Roast in moderate oven (325° F.—16 counts) for about 1¾ hours (about 20-22 minutes per pound per piece). If in larger pieces than 5 pounds, more time is required; however, for 5-pound pieces the time of 1¾ hours after searing should

not be greatly exceeded as roasting longer than this, or allowing the roast to remain in the oven after it is done, tends to make the finished roast dry and hard. Roasting should be started so that the roast will be finished shortly before time to serve; for example, a roast for dinner started about 9:30 AM will be ready to carve at 11:30 AM. When done, carve into thin slices, across the grain. Remove all chunks of fat, bones, and tendons, and render for soup stock. Serve hot with gravy made from the roast drippings. (See recipe 122.)

64. Beef rolls

25 pounds meat scraps, cooked, left- over	2 pounds onions, browned
5 pounds bread crumbs	1 ounce chili pepper
	Salt

Pass the meat scraps through a chopper. Soak the bread crumbs and squeeze out the excess water. Mix well the meat, bread, and seasoning of salt, browned onions, and chili pepper. Make a pie crust or rich biscuit dough rolled into long strips, using recipe for dough for apple rolls (recipe 213). Spread the meat-and-bread mixture about one-half inch thick over the dough. Roll up in lengths equal to that of the bakepan, brush top with beaten eggs, and bake in a slow oven (200°-250° F.—18 to 20 counts) for 1 hour.

65. Beef, simmered

55 pounds beef, fresh (from less ten- der cut)	3 ounces salt
	1 ounce pepper

Cut the beef into pieces weighing about 5 pounds each and wipe with damp, clean cloth. Put in boiling water deep enough to cover. Add salt and pepper and simmer about 3 hours or until tender.

66. Beef, spanish

45 pounds beef, fresh (from less tender cut)	8 pounds onions, chopped
3 cans tomatoes (No. 3 cans)	2 pounds bacon

Cut the beef into 1½-inch cubes and fry in a little fat for about 5 minutes. Pour off the fat and add the tomatoes and onions. Add sufficient beef stock to cover the meat, season to taste with salt and pepper, and allow to simmer for 2 hours. Serve hot.

If desired, season while cooking, with 1 cup Worcestershire sauce.

67. Beef, turkish

35 pound beef, fresh	4 pounds onions, chopped and browned
9 pounds rice	5 gallons beef stock
4 pounds fat	1 pound flour for rolling meat
2 pounds flour, browned in fat	Salt and pepper to taste

71. Beefsteak and onions

60 pounds beef, fresh or 45 pounds if boned
 2 pounds fat
 Salt and pepper to taste
 20 pounds onions, sliced

Prepare and cook the beefsteak as in recipe 68. Peel and slice the onions. Brown in hot fat. Season with salt and pepper. Serve the steak hot on a platter smothered with onions.

72. Beefsteak potpie

35 pounds beefsteak, fresh or cooked, cut in small portions
 4 pounds onions, chopped and browned
 1 clove garlic
 3 gallons beef stock

If fresh steak is used, season the meat with pepper and salt, roll the small pieces of steak in flour, and fry in fat. Remove the cooked steak, add 1 pound of flour to the frying fat, and brown. Add slowly the 3 gallons of stock to make a thin gravy, then add the onions. Pour this onion gravy over the steak.

If cooked steak is used, the onion gravy is made by adding 2 pounds flour to 2 pounds hot fat, then adding the onions.

Make a regular biscuit dough, using about 10 pounds of flour. Cut into biscuits, place them over the top of the steak and gravy, and allow them to brown in the oven. Serve hot.

73. Brains

25 pounds beef brains
 8 pounds onions, diced
 5 pounds bacon, diced

Clean and wash the brains well in cold water, and dice them into about 1/2-inch cubes. Fry the bacon to a golden brown and add the brains. Cook in a moderate oven (250°-325° F.—16 to 18 counts) about 30 minutes, after which add diced onions and season well with chili powder and salt. Cook about 30 minutes longer. Serve hot on toast.

74. Brains and eggs

20 pounds beef brains
 3 pounds bacon
 50 eggs
 Salt and pepper to taste

Clean and wash the brains well in cold water, and dice into about 1/2-inch cubes. Dice the bacon into small cubes or run it through a meat grinder. Fry the bacon until brown. Add the brains and fry until nearly done (about 45 minutes). Add the eggs, beaten slightly, and fry about 10 minutes more. Season to taste with salt and pepper. Serve with dry toast.

This preparation may be enriched by the addition of more eggs and reducing the amount of brains in proportion.

75. Chicken, creamed

60 pounds chicken (fowl) dressed, undrawn	10 cans milk, evaporated, diluted with 6 quarts water (preferably from the boiled chicken)
10 pounds veal, diced	2 pounds butter, or 1 pound butter and 1 pound vegetable shortening
1 dozen eggs	Salt and pepper to taste
2 cans pimento (No. $\frac{1}{4}$ can)	
4 pounds flour	

Singe and draw the chickens, cut into fourths, place in pan with the veal, cover with cold water, and boil until chicken meat falls off the bones. Remove bones (be careful not to leave splinters of bone in the finished product), dice the chicken meat and thoroughly mix with the diced veal. Hard-boil the eggs, dice, and add to the meat.

Make a cream sauce using the butter, flour, milk, and broth from the boiled chicken. Season to taste. Slice pimento into strips (thin), add to cream sauce, and pour the sauce over the meat and eggs. Serve on toast or mashed potatoes.

NOTE.—The addition of two No. 1 cans of mushrooms will improve this dish. Also, any left-over cooked chicken which may be on hand may be used in place of fresh chicken.

76. Chicken fricassee

70 pounds chicken (fowl) dressed, undrawn	4 pounds flour
2 pounds butter or vegetable shortenin ing	8 cans milk, evaporated, diluted by 8 pints water or 8 quarts fresh milk
	Salt and pepper to taste

Cut each chicken into about 12 pieces (natural divisions). Cover with water, season well with celery salt, and allow to simmer until tender. Remove the chicken and make a gravy, using 1 pound butter, 1 pound flour, and the water in which the chicken was cooked. Pepper and salt the chicken well; fry in shallow fat or roll in flour and fry in deep fat. Put into the gravy when fried. Before serving add the milk and the remainder of the butter. Care should be taken to break up the chicken as little as possible. Serve on a platter with or without rice. Old fowls may be utilized to advantage by this recipe.

77. Chicken, fried

75 pounds chicken (fryers or broilers) dressed, undrawn	4 cans milk diluted with 2 pints of water
12 eggs, beaten	4 pounds cracker meal, or flour, or bread crumbs
10 pounds fat	

Fowls over 6 months old should not be fried. Remove pin feathers by singeing over hot blaze. Divide each chicken into about 10 pieces (natural divisions). Fry in shallow fat, or in deep fat. If fried in deep fat, dip each piece in the beaten eggs and then in the cracker meal. If the mixture does not adhere to the pieces sufficiently, repeat the operation. Drain well in a colander and keep hot until served. In case older chickens are used, which are large and possibly tough, fried pieces should be placed in a bakepan with about 2 inches of water, the pan covered, and placed in a slow oven to steam for about 40 minutes.

78. Chicken, roast

75 pounds chicken, dressed, undrawn	15 pounds bread crumbs
4 pounds onions, minced, browned	2 pounds flour
2 pounds fat, butter preferred	

Singe, then clean the chicken well, saving heart, liver, and gizzard, which should be cooked and then minced for use in gravy or dressing. To make the dressing, moisten the bread crumbs with water, mix with onions and giblets, and season with pepper and saft, sage, thyme, or other spices. The bread may be soaked in oyster liquor and oysters added to the dressing. Celery, currants, or raisins may be used instead of onions. Lemon juice or nuts may be added. This dressing may be used with any fowl or fish. Stuff the chicken well with dressing. Sew up with strong thread and tie wings down to the body. Make a batter with the flour and fat, season with salt and pepper, and rub the chicken with it before placing in oven. Roast in a slow oven (200°-250° F.—18 to 20 counts). After the chicken has been in the oven about 20 minutes, add a little hot water and baste every 15 minutes until done. This generally requires about 2½ hours, depending upon the quality of the fowl. Last few minutes of cooking should be at a high heat to brown the outside of the chicken. Carve and serve hot with gravy.

79. Chicken stew with dumplings

60 pounds chicken, dressed, undrawn	Salt and pepper to taste
-------------------------------------	--------------------------

Singe and clean the chicken well and cut into 10 or 12 pieces (natural divisions). Cover with cold water and simmer until nearly done (tender). Then thicken the stew slightly with a flour batter, season to taste with salt and pepper, add the dumplings, and allow to cook 10 or 15 minutes, depending on the size of the dumplings. Dumplings may be made in accordance with the following recipe.

80. Dumplings

9 pounds flour
 3/4 pound fat
 3 ounces baking powder
 3 ounces salt
 Water to make a soft dough

Sift the flour, baking powder, and salt together three times. Mix the fat into the flour and add enough water to make a soft dough. Roll out on a well-floured board to about 1/4-inch thickness. Cut into strips about 1 inch by 3 inches. Drop dough into boiling chicken broth and boil 20 minutes. Serve with the chicken.

Dumplings may also be in biscuit form made by rolling the dough and cutting with a biscuit cutter.

81. Chili con carne

30 pounds meat scraps, fresh preferred, 4 cloves garlic
 but may be cooked 2 ounces chili powder
 6 ounces chili peppers, ground 2 cans tomatoes (No. 3 cans)
 8 pounds chili beans (small red beans) 2 gallons beef stock
 simmered

Simmer the beans until soft. Run two-thirds of simmered chili beans through a food grinder. Trim all the fat from the meat and chop into 1/2-inch cubes, fry, cover with about 1 inch of beef stock, add the ground chili pepper and the chili powder, and salt to taste. Mix with the ground beans, then add the remaining third of the beans whole, the garlic, and tomatoes. While cooking it may be necessary to add more beef stock to replace that lost of evaporation. When ready to serve, there should be sufficient beef stock to cover the preparation. Baked beans may be substituted for chili beans.

82. Chuck steak with onions

60 pounds chuck steak 3 pounds fat
 25 pounds onions Salt and pepper to taste

Peel and slice the onions. Brown in hot fat. Season with salt and pepper. Pound flour into the steaks to make them tender. Brown the steaks on both sides quickly in hot fat. Reduce the heat and cook slowly for 20 minutes or until well done. Season with salt and pepper. Serve the steaks on a platter with the onions around them.

83. Duck, roast

Prepare in the same manner as roast chicken (recipe 78).

84. Goose, roast

Prepare in the same manner as roast chicken (recipe 78).

85. Ham, baked

50 pounds ham, smoked

Wipe the ham with a damp cloth. Place in a pan with the fat side up. Roast in an uncovered pan at 325° F. (16 counts) allowing 25 to 30 minutes per pound. When the ham is done, remove it from the oven and take off the rind. With a sharp knife score fat covering in squares. Stick long-stemmed cloves into the intersections, spread brown sugar over the ham, and return to oven to brown.

86. Ham, simmered

50 pounds ham, smoked

Wash and scape the ham. If the ham is very salty, let soak for several hours in fresh water. Then change the water. The water in which hams are cooked should never be allowed to reach the boiling point. Place hams in near-boiling water (enough to cover) and simmer until the hams are properly cooked. This process requires about 20 minutes to the pound. If two or more hams are simmered in the same vessel, the time of cooking should be computed on the largest ham. Skim all the impurities from the water as they arise. Let the hams cool in the water in which they are cooked.

Mold, if present, may be removed from ham by wiping with a clean cloth dampened with vinegar. The water in which the ham was cooked may be used to cook cabbage, spinach, etc.

87. Ham, smothered

50 pounds ham

 $\frac{1}{4}$ ounce cloves, whole

1 pound sugar, brown

5 pounds bread crumbs

1 gallon milk

2 pounds onions, chopped

Trim off the rind or skin from hams and wipe with a clean cloth. Cut them into slices about one-fourth inch thick and put in a bakepan. Cover with boiling water and cook at a simmering temperature from 35 to 40 minutes. Drain off the water, place over the top the cloves, onions, and bread crumbs, and add the milk. Bake in a moderate oven (250°-325° F.—16 to 18 counts) for about 45 minutes or until the top is crisp and brown.

88. Hamburger

See beefsteak, hamburg (recipe 69).

89. Hash, chop suey

7 pounds bacon, chopped fine	2 ounces chili powder
8 pounds onions, chopped fine	2 gallons beef stock
20 pounds beef, cooked, coarsely ground	4 cans tomatoes (No. 3 cans)
17 pounds turnips, cooked and chopped	4 pounds celery, diced
5 cans corn (No. 2 cans)	Salt and pepper to taste.

Place the bacon in a large bakepan and cook in the oven until well browned. Add the onions and fry, but do not allow to brown. Add the other ingredients and bake for 1 hour. The addition of Worcestershire sauce improves the flavor.

90. Liver and bacon

30 pounds liver, beef, sliced	10 pounds onions, browned
10 pounds bacon, fried	2 pounds flour

Slice the liver thin (about 5 slices per inch) and simmer for 5 minutes. Remove from water, roll the slices of liver in flour, and fry quickly in the bacon fat. Brown the onions and put on liver. Place fried bacon around the onions and liver. Season to taste with salt and pepper. Serve hot.

91. Meat loaf

Same as for beef loaf (recipe 60) except that up to one-half of the beef may be replaced with fresh or cooked pork. If pork is used the loaf should be baked not less than 2 hours.

92. Mutton, simmered

45 pounds mutton	3 ounces salt
1 ounce pepper	

Prepare in the same manner as beef, simmered (recipe 65).

93. Mutton chops

45 pounds mutton loin	Salt and pepper to taste
-----------------------	--------------------------

Cut in chops weighing from 2 to 4 ounces and fry the same as beefsteak. Serve hot. (See recipe 68.)

94. Mutton potpie

Prepare in the same manner as beef potpie (recipe 61) using mutton instead of beef.

95. Mutton stew

35 pounds mutton	3 gallons beef stock or water
40 pounds potatoes	1 pound flour
7 pounds onions	

Cut the mutton into 1-inch cubes. Add sufficient beef stock or cold water to just cover the mutton, and allow to simmer slowly for 1½ hours or until the mutton is done. Add vegetables and cook until done. Season to taste with pepper and salt and thicken slightly with a flour batter. Serve hot with or without dumplings (recipe 80). If dumplings are added, use only 20 pounds of mutton and 30 pounds of potatoes.

96. Omelet, plain

150 eggs
2 pounds drippings or fat
8 cans milk, evaporated, diluted with 8 pints water; or 8 quarts fresh milk
Salt and pepper to taste

Mix the eggs and milk, season, and whip well. Put drippings or other fat into the bakepan, and when the fat begins to smoke pour in the mixture, not more than 3 inches deep, and bake in a medium oven.

97. Omelet, cheese

Same as for plain omelet except that 3 pounds of cheese, chopped very fine, are added before cooking.

98. Omelet, ham

Same as for plain omelet except that 3 pounds of finely chopped cooked ham are added before cooking.

99. Omelet, tomato

Prepare in the same manner as the plain omelet, substituting 8 small cans of tomatoes for the 8 pints of water, or for 4 quarts of fresh milk.

100. Pork chops

60 pounds pork loin

Cut into chops about one-half inch thick and weighing from 3 to 5 ounces each. Fry in a bakepan without added fat until seared, then cover pan until the chops are done. Use a high heat until chops are seared, then finish at lower temperature as high heat after searing will make the chops dry and hard. They may be breaded in flour or corn meal and fried with added fat. Serve with gravy made from the drippings.

101. Pork cutlets

50 pounds pork cutlets
2 pounds flour
2 pounds fat

Dredge each cutlet with flour and fry in shallow fat. Season to taste with salt and pepper. Serve hot with gravy made from the frying. Dipping in egg batter before flouring improves the product.

102. Pork, roast

50 pounds pork, shoulder, butt, or loin, Salt and pepper to taste
or 40 pounds fresh ham

Wipe the roast with damp cloth and cut into pieces weighing about 5 pounds each. Place in an uncovered roaster without water and rub with salt and pepper. Roast in a moderate oven (325°-350° F.—12 to 16 counts). Cook until roast is well done, allowing 30 to 35 minutes per pound for a 3- to 4-pound roast.

103. Sausage, bologna, fried

30 pounds bologna sausage 12 eggs
2 cans milk, evaporated, diluted with 1 3 pounds fat
quart water, or 2 quarts fresh milk

Remove sausage casing and slice about one-half inch thick and dip in batter made by beating eggs and adding milk. Fry in deep fat. Serve hot. Bologna sausage may also be served cold with salad, or made into sandwiches.

104. Sausage, pork

(32 lb. mixture)

20 pounds pork, lean ½ ounce coriander
12 pounds beef, lean ¾ ounce sage
4 ounces salt ½ pint vinegar
3 ounces pepper, black 1 clove garlic

Dice the pork in 1½-inch squares. Grind the beef and mix with the pork, add all the seasoning and mix well, then grind again. The more thoroughly the sausage is mixed, the better it will be. Mold into patties each about 4 ounces and fry without the addition of fat. Serve hot. If too dry, add water. If desired, 10 pounds of dry bread or cracker crumbs or corn meal may be ground in, but this does not improve the product.

105. Sausage, pork, in blankets

30 pounds link sausages 3 pounds flour
2 eggs, beaten 1½ ounces salt
2 pounds lard

Make a dough of the flour, lard, and salt and roll out as for pie crust. Inclose 1 or 2 sausage links in a piece of dough, wash with the egg, and bake until a delicate brown.

106. Sausage, frankfurter

35 pounds frankfurter sausage

Place sausage in boiling water, but do not allow it to boil thereafter, as this causes the skins to crack, rendering them unsightly and injuring the flavor. Long cooking also injures the quality; therefore, the sausage should not be put into the water more than 15 minutes before serving. Serve hot.

107. Sausage, frankfurter, in blankets

Prepare in the same manner as pork sausage.

108. Short ribs of beef

75 pounds short ribs	1 pound fat
3 pounds onions, chopped	2 tablespoonfuls pepper
3 pounds carrots	6 tablespoonfuls salt
6 cans tomatoes (No. 3 cans)	

Melt the fat in bakepan. Add onions and short ribs, cut into pieces containing 1 or 2 ribs, and brown well. Add tomatoes, carrots, and seasoning, and enough water to cover all ingredients. Cover the pan and cook slowly in moderate oven (250°-325° F.—16 to 18 counts) for 3 hours or until done. Serve hot.

NOTE.—If the quantity of carcass beef on hand does not provide sufficient short ribs and it is not desired to purchase any as a wholesale market cut, any shortage can be made up by using chuck meat.

109. Southern creoles

70 pork hocks, fresh	2 quarts tomato catsup
4 cans tomatoes (No. 3 cans)	3 ounces pickling spices

Simmer hocks for 30 minutes, then pour off the water and add the tomatoes, catsup, and spices, salt, pepper. Bake until the meat is done. Pour the cooking mixture as a sauce over the hocks when served. Either strain the sauce to take out the pickling spices or cook spices in a small bag so that they may be removed before serving. Serve hot.

110. Spaghetti, italian style

10 pounds meat, diced, beef preferred (fresh or left over)	1 can tomatoes (No. 10 cans) or 4 cans (No. 2½ or No. 3 cans)
1 pint cooking oil or bacon drippings	1 quart tomato pulp or tomato catsup
2 pounds onions, chopped	8 pounds spaghetti
3 cloves garlic, chopped	Salt, pepper, and paprika to taste

Heat the oil or fat and brown the onions and garlic. Add meat, and brown. Add tomatoes and catsup. Salt and pepper to taste. Simmer until sauce begins to thicken and add paprika to give bright red color. Put spaghetti in boiling salted water and boil 20 minutes or until done. Drain spaghetti and run enough cold water over it to make it firm and keep from becoming a doughy mass but do not chill. Pour the hot sauce over it and serve. Grated cheese may be sprinkled on top.

111. Spareribs

55 pounds spareribs

Cut the spareribs into pieces of 2 or 3 ribs each. There are two principal methods of cooking spareribs:

With sauerkraut.—Place the spareribs on a rack in a bakepan and sear about 15 minutes or until nicely browned in a hot oven (450°–500° F.—8 counts). Remove spareribs and rack and pour off drippings but save these. Place 4 No. 10 cans, or 16 No. 2½ cans, or 4 gallons of fresh sauerkraut in the same bakepan and pour the drippings from the searing over the sauerkraut. Place the seared spareribs on top of the sauerkraut, season highly by sprinkling with pepper, salt, and a little ground sage, and bake in a slow oven (200°–250° F.—18 to 20 counts) for 1 hour. If the spareribs become hard and dry, this can be corrected by covering the pan for the last 15 to 30 minutes of baking and the steam will soften them. Any excess liquid makes excellent soup stock.

With cabbage.—Drop the spareribs into boiling water, then simmer for 30 minutes. Bring the water to a boil again, drop in 50 pounds of cabbage, and boil until cabbage is tender (about 20 minutes).

112. Stew, chop suey

30 pounds meat (pork, beef, or veal) cut in strips ¼ inch thick and 1 inch long	1 pint barbecue sauce (recipe 126) or ½ pint molasses
17 pounds onions, sliced	2 gallons beef stock
4 pounds celery, sliced crosswise	8 pounds rice

Brown the meat, add the stock, and simmer until meat is tender. Add onions, celery, and seasoning and cook 30 minutes before serving. This should be served with 8 pounds of cooked rice.

113. Stew, pan

35 pounds beef, cooked and diced	3 quarts beef stock
20 pounds potatoes, boiled and diced	Salt and pepper to taste
4 pounds onions, chopped	

Mix the beef, potatoes, and onions and season. Put in a well-greased bakepan, spreading to a depth of about 3 inches and add sufficient beef stock to cover the mixture. Bake in medium oven until nicely browned. It should not be as watery as the ordinary stew. All left-over potatoes, except fried, may be utilized in this stew. Left-over parts of roasts and gravy may be used. Serve hot.

114. Stew el rancho

30 pounds meat (beef, pork, or veal), fresh, without bone and with but little fat, cut in about 1½-inch cubes	5 pounds carrots, quartered lengthwise 7 pounds turnips, sliced across grain 7 pounds cabbage, cut in eighths 5 pounds onions, small whole 2 ounces chili powder
15 pounds potatoes	
2 cans tomatoes (No. 3 cans) or 10 pounds fresh tomatoes	

Place the meat, turnips, carrots, and tomatoes in a large pan. Simmer until the meat is tender and then add the remaining vegetables. Season with salt and chili powder, and simmer until vegetables are done. All ingredients should be thoroughly cooked but not broken into pieces. The liquid should cover all the solids by about an inch. The stew is improved by a bunch of parsley chopped fine and added just before serving; a few sprigs of parsley may be used for garnishing. Serve hot with the vegetables whole, if possible. Any kind of fresh meat and any vegetables may be used in this stew.

115. Stew, irish

30 pounds beef, fresh, or left-over beef	1 pound flour
20 pounds potatoes, peeled	2 gallons beef stock
5 pounds onions	

Select cuts of beef suitable for stewing from less tender cuts and dice into ½-inch cubes or smaller, cutting all about the same size. Cook at a simmering temperature until nearly tender. Dice the potatoes into 1-inch cubes, chop the onions, and add both to the meat. Add beef stock or water to cover the ingredients in the pan about 1 inch. Season to taste with salt and pepper and thicken with batter made of flour. Simmer until the vegetables are thoroughly done. This stew is improved by the addition of 3 pounds of diced carrots or turnips or three No. 3 cans tomatoes. To make a potpie out of this, cover with a biscuit dough and bake in a medium oven (325°-400° F.—12 to 16 counts). To improve the appearance, the dough may be washed with a beaten egg, which will give a golden brown color. Serve hot.

116. Tamales

20 pounds cooked meat scraps	3 ounces salt
1½ pounds corn meal	2 ounces chili powder
8 pounds flour	1 clove garlic, chopped fine
5 pounds mashed potatoes	1 quart beef stock

Run the meat through a chopper. Add salt, pepper, garlic, and chili powder, and mix well. Add the beef stock. Mix the corn meal, flour, and potatoes with enough water to make a stiff dough. Roll out this dough $\frac{1}{4}$ inch thick, using flour for dusting. Cut the dough in long strips about $2\frac{1}{2}$ inches wide. Place on each strip enough meat to form a core about $\frac{1}{2}$ inch in diameter. Fold the sides of the strip together and seal by moistening the edges with water and pressing together. Cut the rolled strips into pieces about 5 inches long. Fresh meat may be used in making tamales, in which case the fat is cut off and the meat is cut into $\frac{1}{2}$ -inch cubes and cooked until well done in a small amount of fat. Then proceed as outlined above. Fry the tamales in deep fat. Serve hot.

117. Turkey, roast

Prepare in the same manner as roast chicken, substituting 70 pounds of turkey, undrawn.

118. Veal cutlets

50 pounds veal	1 pound flour
----------------	---------------

Cut in slices weighing about 4 ounces each, roll in flour, and fry the same as beefsteak. Serve hot with cream gravy made from the fryings.

119. Veal, roast

70 pounds veal	1 pound fat
----------------	-------------

Lard with fat. Roast in a moderate oven (325° F.—16 counts) for 30 minutes per pound.

120. Yorkshire pudding

10 pounds flour	2 ounces salt
8 ounces baking powder	Pinch cayenne pepper
12 eggs	

Sift together three times the flour, baking powder, salt, and cayenne pepper. Add eggs, whipped to a foam, and sufficient water to make a dough somewhat softer than that used for biscuits. Drop the dough from the hand into the pan in which beef has been roasted, keeping the handfuls about 1 inch apart. Bake in a medium oven (325° – 400° F.—

12 to 16 counts). The above recipe may be improved by substituting milk for water.

GRAVIES AND SAUCES

121. Flour batter (for thickening liquids)

Flour

Water

The quantity of flour used will depend upon the quantity of liquid to be thickened and the thickness desired. One quart of water, mixed with 1 pound of flour will thicken to gravy consistency about 2½ gallons of liquid. The thickness of the liquid will also depend upon the length of boiling, after putting in the batter, as long boiling evaporates more of the moisture and results in thicker liquid. Care must be used in mixing the batter with the liquid as constant stirring is necessary to prevent lumping.

122. Gravy, brown

1 quart fat

2 gallons water

2 pounds flour

The gravy should be made in the pan used in roasting the meat, as only by this method can all the extractives lost from the meat be retained in the gravy. Brown gravy is made from the drippings of roasted meat or fowl and the frying of pork. One quart of fat will make 2 gallons of gravy. Take the fat in the roasting pan after the meat or fowl has been removed, heat to the smoking point, and add enough flour to absorb the hot fat, stirring constantly to prevent burning and lumping. When the flour is brown, add cold water (about 1 gallon to the pound of flour used) and continue cooking and stirring until the gravy is smooth and of the desired thickness or consistency. Salt and pepper to taste. Serve hot. Brown gravy may also be made from stock by the same procedure, except that 2 quarts of stock are used instead of 1 quart of drippings; however, gravy made from stock is not nearly as palatable as that made from roast drippings.

123. Gravy, cream

8 cans milk, evaporated, diluted with 1 quart fat

8 pints water, or 1½ pounds powdered 2 pounds flour

skim milk dissolved in 7¼ quarts

water, or 2 gallons fresh milk

Cream gravy is made from the fryings of beef or fowl. Follow the same procedure as in making brown gravy, except that the flour is not browned and milk is used instead of water.

124. Gravy, giblet

This should be made only when poultry is roasted or fried. Chop the cooked gizzards, hearts, and livers of the fowls and add to a cream gravy made from the drippings.

125. Gravy, stock

10 quarts stock
2 pounds flour

2 gallons water

Heat the stock to the boiling point and sift in the flour slowly, stirring constantly. If a brown gravy is desired, continue cooking until the flour is browned, then add the water and continue cooking and stirring until of the desired thickness, but if white gravy is desired do not brown the flour. Season with salt and pepper. Serve hot. This gravy should be made only when drippings or frying are not available.

126. Sauce, barbecue

1 gallon catsup
1 gallon vinegar
2 to 3 cups dry mustard
2 tablespoons red pepper

3 tablespoonfuls black pepper
 $\frac{3}{4}$ cup chili powder
2 medium size pieces garlic
 $\frac{1}{2}$ cup salt

Bring to boil and let boil 2 hours or until it begins to thicken. Mix well and keep it stirred.

127. Sauce, cranberry

17 quarts cranberries

6 pounds sugar

Wash and stem the berries, put in a boiler, and cover with about 1 inch of cold water. Cover tightly and boil until berries break to pieces and cover themselves with their juice. Remove the lid and simmer for 30 minutes. If a sauce free of skins is desired, rub through a colander. Then pour into an earthen or wooden vessel and cool. Serve cold with chicken, turkey, or other kinds of meat.

128. Sauce, cream, for codfish

2 pounds fat

1 pound onions, minced

7 cans milk, evaporated, or 23 ounces powdered skim milk dissolved in 5 $\frac{1}{2}$ pints water

10 eggs, hard-boiled, minced

1 pound pickles, minced

Thicken 1 gallon of boiling water with a flour batter and season with pepper and salt. Bring to a boil and add the fat, milk, onions, eggs, and pickles; whip well and spread over the fish on the platter. The sauce may be improved by the addition of 6 or more hard-boiled eggs, chopped fine.

129. Sauce, plum pudding

1½ pounds sugar
 1 tablespoonful lemon extract
 ½ pint vinegar
 3 quarts water
 4 ounces cornstarch or flour

1 can milk, evaporated, diluted with 1
 pint water, or 3¼ ounces powdered
 skim milk dissolved in ¾ pint water
 ½ ounce salt

Dissolve the sugar in 3 quarts of water. Bring to a boil and add a batter made of the cornstarch or flour and ½ pint of cold water. Add the vinegar, milk, extract, salt, and a pinch of baking soda. Simmer until smooth.

130. Sauce, rhubarb

25 pounds rhubarb

5 pounds sugar

Wash the rhubarb and dice in ½-inch cubes and place in a boiler with about 1 inch of water. Cover tightly and simmer for about 1½ hours. Then remove the lid and allow the water to evaporate for about 1 hour. Sweeten with sugar and serve alone as a fruit sauce, or with roast mutton, lamb, or veal, or poured over plain cake. The sauce may be improved by adding other fruit or fruit juices.

131. Sauce, spanish, fish

2 pounds fat
 4 pounds onions, minced
 2 cans tomatoes (No. 10 cans)
 5 cloves garlic, mixed

5 ounces red pepper, ground
 2 gallons beef stock
 Salt to taste

Fry onions and garlic in shallow fat until well done, then place in a double boiler with the tomatoes, beef stock, and seasoning, and heat thoroughly. Thicken slightly with a flour batter.

132. Sauce, sweet, chocolate

Same as sweet sauce, vanilla, except 8 ounces melted chocolate are used in place of ¼ cup vanilla extract.

133. Sauce, sweet, lemon

Same as sweet sauce, vanilla, except ⅛ cup lemon extract is used in place of ¼ cup vanilla extract.

134. Sauce, sweet, vanilla

9 pounds sugar
 1½ gallons water
 8 ounces cornstarch

¼ cup vanilla extract
 ½ teaspoonful salt
 ¼ pound butter or vegetable shortening

Mix sugar and cornstarch, stir into the boiling water and boil until slightly thickened. Add butter, flavoring, and salt, and cook until of desired thickness, which will depend upon use. This sauce may be made richer by using milk in place of all or a part of the water. Variations of this sauce may also be made by adding cooked fruit (run through a grinder) or by caramelization of part of the sugar.

135. Sauce, tomato

10 cans tomatoes (No. 3 cans) or equivalent in fresh tomatoes	3 ounces salt
2 pounds onions, chopped fine	3 ounces sugar
1 ounce cinnamon, ground	2 pounds butter, or 1 pound butter and 1 pound vegetable shortening
½ ounce cloves, ground	1 pound flour
5 chili pods, chopped fine, or chili pepper ground	1 clove garlic, chopped fine

Boil slowly all the ingredients except the flour and butter, in 2 quarts of water for 1½ hours. Remove from the range and run through a fine colander or sieve. Replace on the range. Heat the butter in a frying pan, add the flour, stir until smooth, and add it to the sauce. Excellent for fish, meats, or croquettes.

FISH AND SEA FOOD DISHES

136. Codfish cakes

17 pounds salt codfish	1 pound flour, or 2 pounds cracker crumbs
17 pounds potatoes, mashed	
20 eggs	2 pounds fat

If whole cod is used, soak, remove the bones, and pass through a meat chopper. Mix with the potatoes and eggs, and season with pepper and salt. Mold into cakes weighing about 3 ounces each and roll in cracker crumbs or flour and fry in deep fat. Serve hot with tomato sauce. These cakes may be improved by dipping in egg batter before frying; the batter is made by mixing 12 eggs and 2 cans of evaporated milk diluted with 2 pints of water or 2 quarts of fresh milk, or 7 ounces powdered skim milk dissolved in 1½ pints water.

137. Fish, baked

35 pounds fish, fresh	5 pounds bacon or salt pork
-----------------------	-----------------------------

Dress fish and place in a bakepan containing about 1 inch of water with 1 to 4 slices of bacon over each fish according to size. Season well with pepper and salt. Bake in medium oven (325°-400° F.—12 to 16 counts) for 1 hour or until done, basting frequently. The entrails may be withdrawn from beneath the gills without opening the

belly and the fish filled with dressing. Fish weighing less than 2 pounds are not suitable for baking.

138. Fish, fresh, fried

35 pounds fish, fresh	1 pound flour
1 pound corn meal or cracker meal	2 pounds fat

Clean and slice (or split) into pieces not more than 1 inch thick. Season with salt and pepper, roll in flour and corn meal, and fry in deep fat until thoroughly browned. Serve hot with tomato sauce.

139. Oysters, fried

4 gallons oysters (selects) shucked (6 or 8 for each man, according to size)	30 eggs 7 pounds cracker dust 7 pounds fat
--	--

Dip oysters in egg batter and then in cracker dust. Take one oyster at a time between the hands, press flat, and lay in the hot deep fat. Fry until slightly brown. Serve hot with tomato or Worcester-shire sauce.

140. Oysters, scalloped

12 quarts oysters, standards, or shucked (about 6 oysters for each man)	3 pounds bacon 6 cans milk, evaporated, or 18 ounces powdered skim milk dissolved in 5 pints water
10 pounds bread, diced and toasted, or 10 pounds crackers	

Dice the bacon and fry until crisp. Add the oysters and bring to a boil, then mix in the bread or crackers and simmer 15 to 20 minutes. Add the milk just before serving.

141. Salmon cakes

20 cans salmon (1-pound cans)	2 pounds cracker or bread crumbs
20 pounds potatoes, mashed	2 pounds fat
20 eggs	

Mix the ingredients well, season to taste with salt and pepper, make into cakes about 3 inches in diameter, roll in flour, and fry in deep fat. Serve hot with tomato sauce.

142. Salmon hash

20 cans salmon (1-pound cans)	1 quart beef stock
15 pounds potatoes, mashed	10 pounds onions

Mix ingredients well, adding a little beef stock. Season with salt and pepper, spread 3 inches deep in a greased bakepan and bake in

a medium oven (325°-400° F.—12 to 16 counts) for 40 minutes or an hour. Serve hot.

VEGETABLE DISHES

143. Asparagus

15 cans asparagus (No. 2 cans) or 20 15 pounds bread, toasted
pounds fresh asparagus

Canned asparagus.—Open the cans and heat (not boil) the contents. Serve hot on toast with a cream sauce made from the liquid from the asparagus. Season with salt and pepper to taste.

Fresh asparagus.—Clean and wash asparagus and put in boiling salted water for 15 minutes. Drain and serve on toast as above.

144. Baked beans

18 pounds beans, dry	2 ounces mustard, dry, or 6 ounces prepared
4 pounds bacon, sliced	2 pounds onions, chopped
1 pint molasses	2 pounds tomatoes, fresh, or one can tomatoes (No. 3 can)
1 pint catsup	

For serving as an additional vegetable, use one-half of this recipe.

Wash and soak the beans for 4 hours or overnight in cold water. Drain, place in hot water, and simmer for 2 hours. Drain and place beans in bakepan or covered earthen crocks. Mix in the chopped onions and tomatoes. Season to taste with salt and pepper. Place sliced bacon on top of the beans. Make a mixture of the molasses, catsup, and mustard, adding a little vinegar if dry mustard is used, and pour over the beans. Cover the pan and bake in a slow oven (below 200° F.—24 counts) for 4 hours, or until tender. Serve hot.

In cold weather the soaking may be overnight, in which case the 2-hour simmering will not be necessary. In hot weather the beans may sour if soaked when a cool temperature cannot be obtained. When this condition is met with, beans may be baked as follows:

Wash the beans in cold water, drain, and place in cold water; simmer 45 minutes, drain, and put beans in bakepan. Mix in chopped onion and tomatoes and season with salt and pepper. Place sliced bacon on top of the beans. Make a mixture of molasses, catsup, and mustard, and pour over the beans. Cover the pan and bake in a slow oven for 5 hours, or until tender. Serve hot.

145. Beans, canned

4 cans beans, baked (No. 10 cans) or 20 cans beans (No. 2 cans)

For serving as an additional vegetable use one-half of this recipe.

Open the cans and empty into bakepans or, if they cannot be heated in the oven, place in boilers. They may be served after simply heating (requiring about 15 minutes) but will be improved by adding 2 bottles or one-half of a No. 10 can of catsup, also about 12 whole onions, $\frac{1}{2}$ gallon of pickles, 2 or 3 pounds of sliced or cut bacon, 2 quarts of molasses, and 8 ounces of prepared (wet) mustard. The quantities of these additional ingredients may be varied according to what is on hand. The bacon should be laid on top of the beans, but onions, pickles, molasses, and mustard should be mixed through them. If bacon and onions are added, it is necessary to bake or cook the beans at least 30 minutes. If this is done the temperature should be kept below the boiling point if in a boiler, and if in an oven at slow heat (200°-250° F.—18 to 20 counts).

NOTE.—In the absence of any other means of cooking, canned beans (as well as any other canned food) may be heated for serving by immersing the cans for about 15 minutes in hot or boiling water. The heat causes an internal expansion which may cause the hot contents to spurt out when the can is opened after removing from the hot water, and the cook who opens the cans must use care to avoid being scalded. If it is desired to prevent contamination of the water in which the unopened cans are heated, the labels should be removed and the cans washed clean before immersing.

146. Beans, dry, simmered

20 pounds beans, dry

4 pounds bacon, sliced, or ham hocks,
or salt pork

For serving as an additional vegetable, use one-half of this recipe.

Wash the beans thoroughly, place in a boiler with about 4 gallons of cold water and bring to a boil, then skim and simmer for 4 hours or until done. After they have simmered about 2 hours, add the meat and season to taste with salt and pepper. Water added during cooking should be boiling hot. Serve hot.

147. Beans, lima, green or soaked, canned

4 cans lima beans, green or soaked 2 pounds bacon, sliced, or ham hocks,
(No. 10 cans) or 20 cans (No. 2 cans) or salt pork

If the meat is not added, the beans can be heated for serving in about 15 minutes. If the meat is added, open the cans, add the meat, and simmer for about 1 hour.

148. Beans, lima, dry, simmered

15 pounds lima beans, dry

2 pounds bacon, sliced, or ham hocks,
or salt pork

Wash the beans thoroughly and place them in a boiler with about 4 gallons of cold water, boil 10 minutes, and skim. Add the meat and season with salt and pepper to taste, then simmer 4 hours or until tender. Serve hot.

149. Beans, string or snap, canned

4 cans beans, string (or snap) (No. 10 cans) or 20 cans beans (No. 2 cans) 3 pounds bacon, sliced

Empty the cans into a bakepan or boiler, add the bacon, and simmer about 20 minutes. If necessary to heat the beans in the cans, the bacon may be simmered separately and added after the cans are opened.

150. Beans, string or snap, fresh

26 pounds beans, string or snap, fresh 3 pounds bacon, sliced

Cut off tips, then break the beans into pieces about 1 inch, wash and place in a closed boiler with sufficient water to one-third cover them. Then add the bacon and season with salt and pepper to taste. Simmer for 1 hour, adding more water or beef stock, if necessary to barely keep the beans covered. Serve hot.

151. Beets, fresh, boiled

26 pounds beets

Clean the beets thoroughly but do not skin or cut off roots. Boil until well done, then hold under a faucet of cold water and rub the skins off with the hands and remove roots. Cut into slices or, if young and tender, serve whole. Serve hot with butter, cream sauce, or gravy. While washing and cooking be careful not to break the skins as to do so would cause bleeding.

152. Beets, canned

4 cans beets (No. 10 cans) or 16 cans beets (No. 2½ cans)

If desired to serve as boiled beets, heat sufficiently for serving and serve hot with butter, cream sauce, or gravy.

153. Beets, harvard

3 cans beets (No. 10 cans) or 12 cans beets (No. 2½ cans), or 25 pounds beets, fresh	3 ounces cornstarch
3 pounds sugar, granulated	1½ ounces salt
	1 quart vinegar
	1 pound butter

If fresh beets are used, clean and boil until tender, then drain and remove skins and roots. Cut the beets into thin slices or cubes. Sift together the sugar, cornstarch, and salt, mix with the vinegar, and boil this sauce 5 minutes, stirring constantly to prevent scorching. Add the butter and, when melted and stirred in, pour the sauce over the beets which should be heated if cold. Let stand a few minutes to absorb the sweet-sour flavor of the sauce.

Serve alone as an additional vegetable, or with meats. If served with meats, use one-half of this recipe.

154. Beets, pickled

30 pounds beets

2 quarts vinegar

Boil the beets until done, then rub the skins off under cold water with the hand, cut into $\frac{1}{4}$ -inch slices, and season with salt and vinegar. If desired, 1 pound of sugar may be added to the vinegar. Allow them to stand about 5 hours before serving.

155. Cabbage

When preparing cabbage, take off dead and dry outer leaves. Slice about $\frac{1}{2}$ inch off the stalk of each head and place the head in cool fresh water, being sure that stem end is immersed in the water for several hours. The cabbage will take up water through the stem as a flower would, and become cool and crisp. Cabbage should never be overcooked until it assumes a tan color. Cooked cabbage should always retain the natural green color. It should be cooked only long enough to make it tender. This requires only about 20 minutes for boiled cabbage. Always boil in an open kettle, as this allows strong odors to escape.

156. Cabbage, bavarian

35 pounds cabbage

$1\frac{1}{2}$ quarts vinegar

4 pounds salt pork or bacon

Strip off outer leaves and remove the cores; cut into fine shreds, wash and soak, and place in a boiler containing the pork or bacon, vinegar, and 2 gallons of water. Season with salt and pepper. Boil rapidly in an open boiler for about 20 minutes, adding boiling water, if necessary, to keep covered. Then thicken slightly with a flour batter and boil for about 5 minutes longer. Serve hot.

157. Cabbage, boiled

45 pounds cabbage

8 pounds bacon or salt pork, or
corned beef

Strip off the outer leaves, remove the cores, wash, quarter, and soak. Place in a boiler with sufficient water to cover. Add the meat, and season to taste with salt and pepper. Cook in an open boiler for 20 minutes, adding boiling water as required to keep the cabbage completely covered at all times. Serve hot.

158. Cabbage, fried

35 pounds cabbage, boiled

4 pounds bacon drippings

Chop the cabbage fine and add to it the bacon drippings. Season with salt and pepper. Cook on a range in a covered bakepan about $\frac{1}{2}$ hour, stirring frequently to prevent burning. Serve hot.

Fried cabbage may also be made from finely chopped raw cabbage.

159. Carrots, baked

25 pounds carrots, fresh

2 pounds bacon drippings

Scrape the carrots and cut into slices not more than $\frac{1}{2}$ inch boiler containing sufficient cold water to cover. Boil until tender. Remove and place in a bakepan containing the bacon drippings. Season to taste with salt and pepper, and bake in a medium oven (325° – 400° F.—12 to 16 counts) for about 20 minutes. Serve hot.

160. Carrots, candied

45 pounds carrots, fresh

5 pounds sugar, granulated, or brown
(brown preferred)

1 pound butter

1 gallon beef stock, strained

Clean and scrape the carrots, and slice lengthwise. Boil until medium done (about 20 minutes). Spread the slices in three layers in a bakepan, putting about one-third of the sugar and butter on top of each layer. Pour the beef stock over the whole and bake in a medium oven (325° – 400° F.—12 to 16 counts) 40 minutes to 1 hour, or until well browned. Serve hot.

This recipe is sufficient for the main vegetable dish to take the place of potatoes. If served as an additional vegetable, use one-half this recipe.

161. Carrots, mashed

30 pounds carrots, fresh

7 quarts beef stock

2 pounds bacon drippings

Scrape the carrots and cut into slices not more than $\frac{1}{2}$ -inch thick. Place in an open boiler containing the beef stock or water. Season with salt and pepper and simmer until tender. Add the bacon drippings and mash thoroughly. Serve hot.

162. Corn, canned

4 cans corn (No. 10 cans) or 20 cans $\frac{1}{2}$ pound butter
corn (No. 2 cans)

Put corn in a boiler and season to taste with salt and pepper. Mix well, simmer until hot, and add the butter. If the corn is too thick, it may be thinned with milk or water. Serve hot.

163. Corn, fried

3 cans corn, whole kernel style (No. 10 cans) or 15 cans corn (No. 2 cans) or 20 pounds corn cut from roasting ears (corn on the cob) after cooking
1 cup green peppers, minced
 $\frac{1}{2}$ pound butter
 $\frac{1}{2}$ pound bacon drippings

Drain liquid from corn. Mince peppers. Heat butter and bacon drippings in bakepan until just below smoking point. Place green peppers (minced) in hot fat and fry 5 minutes. Add corn to pan and lower heat. Stir frequently. Serve when thoroughly heated. Care must be used to prevent scorching.

164. Corn fritters

2 cans corn, cream style (No. 10 cans) or 15 cans corn (No. 2 cans)
24 eggs
 $2\frac{1}{2}$ ounces salt
10 pounds flour
5 ounces baking powder
2 gallons milk or water

Beat the corn and eggs together thoroughly. Sift together the salt, flour, and baking powder three times. Add a portion of the liquid, then a portion of the sifted dry ingredients, stirring well. Continue until the dry ingredients are thoroughly mixed in, regulating quantity of liquid to make a thick batter which will just drop off the spoon. A thin batter makes a poor product. Using a large basting spoon, drop spoonfuls into hot fat and fry until brown. There are two methods of frying: In hot fat about $\frac{1}{2}$ inch deep; or in fat deep enough to cover the fritters. Serve hot with sirup.

165. Corn, scalloped

4 cans corn, cream style (No. 10 cans) or 20 cans corn (No. 2 cans)
1 pound butter
2 pounds flour
1 quart milk
4 pounds cracker or bread crumbs
Salt and pepper to taste

Make a white sauce of the butter and flour. Let this partly cook, then add the milk and corn. Season to taste. Mix thoroughly, and put a layer of this mixture into a bakepan; over this put a layer of broken crackers or bread crumbs and repeat until pan is filled. Dot

the top with a little butter or vegetable shortening. Bake in a medium oven (325°-400° F.—12 to 16 counts) about 30 minutes or until nicely browned.

166. Eggplant

25 pounds eggplant
12 eggs

2 pounds flour
6 pounds fat

Peel the eggplant and slice lengthwise. Beat the eggs well and add to them about 3 pints of water or milk. Season the eggplant with salt and dip it in the egg and water mixture, roll in flour, and fry in deep fat until browned. Place in a colander and drain before serving. Serve hot.

167. Greens

30 pounds greens
1 quart beef stock

4 pounds bacon

Wash in cold water, changing water at least four times to remove grit. Put the greens and bacon in 4 gallons of cold water and boil in an open boiler until tender (about 10 minutes). Serve hot, season to taste with salt, pepper, and vinegar or add the following preparation: Remove the bacon and strain the free water from the greens, chop greens fine and place in a well-greased bakepan, add beef stock to moisten, and bake in an oven for about ½ hour. Season with salt and pepper to taste. Slice the bacon and serve on top of the greens. Greens may be improved in appearance and taste by the addition of minced hard-boiled eggs in the serving dish. Excessive cooking will destroy their vitamin properties.

Beet tops, dandelion, spinach, turnip tops, and other greens may be prepared in the same way.

168. Hominy

3 cans hominy, lye (No. 10 cans) 2 ounces salt

Place the hominy and salt in a boiler and simmer for 20 minutes. Season with pepper to taste. Serve hot.

169. Macaroni and cheese

8 pounds macaroni 4 pounds cheese, diced

Add the macaroni to 7 gallons of salted boiling water or beef stock and boil for 20 minutes. Strain the free water off and spread about one-third of the macaroni in the bottom of a well-greased bakepan, followed by one-third of the diced cheese, and continue in alternate

layers until all of both ingredients are in the bakepan. Bake in an oven about 30 minutes, sprinkle with paprika, and serve hot. If desired, 2 or 3 pounds of toasted bread crumbs and 2 or 3 cans of tomatoes may be mixed with the cheese between the layers of macaroni.

170. Onions, boiled

20 pounds onions

Select small onions, peel, and boil whole until tender (from one-half to three-fourths of an hour) and serve with cream sauce.

171. Onions, fried

30 pounds onions

4 quarts beef stock

2 pounds lard or drippings

Peel and slice onions, put all ingredients in a bakepan on a hot fire. When the stock is all evaporated, the fat in the pan will be sufficient to brown the onions. Stir frequently and season to taste with pepper and salt. May be used to smother beefsteak or served separately as a vegetable.

172. Onions and grated cheese

25 pounds onions

2 pounds cheese, chopped fine

2 pounds fat

Peel and slice the onions and fry until well done. Mix the chopped cheese with the onions and bake in a quick oven (400°-450° F.—9 to 12 counts) for 20 minutes. Serve hot.

173. Parsnips, baked

30 pounds parsnips

2 quarts beef stock

5 pounds bacon

Scrape and wash the parsnips thoroughly and place them in a well-greased bakepan. Season to taste with pepper and salt and add the beef stock. Place strips of bacon over the parsnips and cover the pan to prevent evaporation. Bake in a slow oven (200°-250° F.—18 to 20 counts) for about 1 hour, or until tender. Serve hot.

174. Parsnips, mashed

30 pounds parsnips

7 gallons water

2 pounds bacon drippings

Scrape and wash the parsnips thoroughly and place in an open boiler containing the water. Simmer until tender, pour off the free

water, and add the bacon drippings. Season with salt and pepper to taste, and mash thoroughly.

Mashed parsnips left over may be served later by preparing as follows: Place in a bakepan, level the top, and grease lightly, then place in the oven until browned (about 40 minutes). Serve hot.

175. Parsnips, sugared

30 pounds parsnips	1 ounce cinnamon, ground
2 quarts beef stock	Salt and pepper to taste
2 pounds sugar	

Scrape and wash the parsnips thoroughly, slice lengthwise, and place them in a well-greased bakepan. Season to taste with salt and pepper. Pour over them the beef stock. Cover the bakepan to prevent evaporation. Bake in a slow oven (200°-250° F.—18 to 20 counts) for about 1 hour, or until tender. Sift the sugar and cinnamon together. About 5 minutes before taking out of the oven, sprinkle this sugar-cinnamon mixture over the parsnips and replace in the oven until the top begins to brown.

176. Peas, creamed, canned

3 cans peas (No. 10 cans) or 16 cans peas (No. 2 cans)	2 cans milk, evaporated, or 6 ounces powdered skim milk and 1½ pints water
1 pound butter	
1 pound flour	

Put the peas into a stewpan and season with pepper and salt to taste, then add the butter and bring to a boil. Thicken slightly with a flour batter made with milk and flour. Reheat and serve hot.

177. Peas, green

14 quarts peas, green	2 cans milk, evaporated, or 2 quarts fresh milk
5 quarts beef stock	
1 pound butter or drippings	

Hull and wash the peas in cold water. Place in a boiler or stewpan containing the hot beef stock and butter. Season with salt and pepper and boil about 15 minutes. Thicken with a flour batter and bring to a boil again, then add the milk, and serve hot.

178. Potatoes, baked

35 pounds potatoes, fresh

Select and wash (do not peel) potatoes of about the same size. Grease each potato and place in a bakepan and cover with a larger

pan. Bake in a quick oven (400°-450° F.—9 to 12 counts) until well done, usually about 45 minutes. Do not pierce with a fork. If they seem soft when pressed, they are done. Baking over an hour may cause the potatoes to become dark and soggy. Serve hot with butter.

179. Potatoes, boiled

35 pounds potatoes, fresh

Peel and wash the potatoes, cut into pieces, and place in boiling water. Boil briskly until thoroughly done (about 30 to 40 minutes). Drain and leave on stove a few minutes to dry. Serve hot.

180. Potatoes, boiled in jackets

35 pounds potatoes

Select and clean potatoes of uniform size. Soak them a few minutes in cold water, then put them in boiling water and cook until tender, which requires about 40 minutes. When tender, drain off free water. Do not allow potatoes to boil until broken as this will cause them to absorb the water and become pasty and soggy. Remove the kettle to back of stove, allowing the steam to escape. The cooking should be so regulated that they can be served immediately when ready.

181. Potatoes, browned

35 pounds potatoes

Select and clean small potatoes and boil them until done, then peel and grease each potato and spread them in a single layer on the bottom of a well-greased bakepan. Bake in an oven until brown, usually about 30 minutes.

182. Potato cakes

30 pounds potatoes

4 ounces parsley, green, chopped

2 pounds flour

Run the peeled and cooked potatoes and the parsley through a food grinder and mold into cakes weighing about 3 ounces. Fry in shallow fat until nicely browned and crisp. May be served with any kind of meat. Left-over potatoes prepared in any manner may be used in this recipe. Soaked bread crumbs may be added to fill out quantity for one meal. Do not add more than 5 pounds bread to 30 pounds potatoes.

183. Potatoes, cheesed (au gratin)

30 pounds potatoes (left-over or boiled)	4 cans milk, evaporated, or 1 pound
1 gallon beef stock	powdered skim milk dissolved in
2 pounds cheese, chopped or grated	3 pints water
1 pound flour	½ pound shortening
	½ pound butter

Use any left-over boiled or baked potatoes. Cut into pieces about the size of a lima bean, season to taste with salt and pepper, and mix with the beef stock. Melt the shortening and add flour and milk, making cream sauce. Spread the potatoes 2 or 3 inches deep on the bottom of a well-greased bakepan. Pour the cream sauce over the potatoes, sprinkle with chopped or grated cheese, dot here and there with small pieces of butter, and bake in a quick oven (400°-450° F.—9 to 12 counts) for about 30 minutes until browned. Serve hot.

184. Potatoes, creamed

30 pounds potatoes	4 ounces parsley
1 gallon beef stock	2 pounds flour
2 cans milk, evaporated, or 6 ounces	1 pound butter
powdered skim milk dissolved in	
1½ pints water	

Clean and boil the potatoes with jackets on until well done, then peel and slice them crosswise. Allow the beef stock to come to a boil on the range, thicken it with a flour batter, and add the milk. Place the potatoes in a bakepan and cover them with the beef stock and batter mixture, add the butter, bring to a boil, and remove from the range immediately. Meanwhile, chop the parsley fine and sprinkle over the potatoes before serving. Serve hot.

185. Potatoes, french baked

35 pounds potatoes	4 quarts beef stock
2 pounds fat	

Clean, peel, and cut the potatoes in halves lengthwise. Place them in a well-greased bakepan and salt to taste, then add the stock and fat. Mix thoroughly and cook in a medium oven (325°-400° F.—12 to 16 counts) about 1 hour, or until the potatoes are tender. Do not stir while cooking. Serve hot.

186. Potatoes, french fried

50 pounds potatoes	7 pounds fat
--------------------	--------------

Clean and peel the potatoes and cut them lengthwise into ½-inch slices. Fry in deep fat until nicely browned. Do not place too

many of the potatoes in the fat at one time, as this cools the fat and makes the fried potatoes grease-soaked. Drain and salt. Serve hot.

187. Potatoes, fried (sautéed)

40 pounds potatoes, unpeeled 1 pound fat

Wash the potatoes and boil with jackets on until tender. When cool, peel and slice crosswise. Season with salt and pepper to taste and add sufficient hot fat to moisten. Spread over the bottom of a well-greased bakepan to the depth of about 2 inches, and fry in a quick oven (400°-450° F.—9 to 12 counts) or on top of the range for about 30 minutes. Serve hot. Care should be taken not to get the potatoes too greasy. They may be fried in shallow fat without first being moistened with hot fat, but must be carefully watched to prevent burning.

188. Potatoes, german boiled

30 pounds potatoes 2 pounds onions, browned

Clean, peel, and cut the potatoes into pieces about the size of an egg, place in cool water, and boil until done. Then place in vegetable dishes and spread about 2 basting spoonfuls of browned onions over the contents of each dish. Serve hot.

Potatoes left over from this recipe may be used in lyonnaise potatoes, salads, fried potatoes, hash, stews, and various other dishes.

189. Potatoes, hashed browned

30 pounds potatoes 1 gallon beef stock

Cut the cooked potatoes into pieces about the size of a lima bean. Season to taste with salt and pepper, and mix with beef stock. Spread 2 or 3 inches deep over the bottom of a well-greased pan. Spread a little fat over the top and bake about 30 minutes in a quick oven (400°-450° F.—9 to 12 counts). Serve hot.

190. Potatoes, lyonnaise

40 pounds potatoes, unpeeled 8 pounds onions

Wash the potatoes and boil them with jackets on until tender, then peel and slice crosswise. Wash and slice the onions, fry them brown, and add to the potatoes. Season to taste with pepper and salt, adding sufficient melted fat to moisten. Spread 2 inches deep in the bottom of a well-greased bakepan. Bake about 15 minutes in quick oven (400°-450° F.—9 to 12 counts). Serve hot.

191. Potatoes, mashed

40 pounds potatoes	2 cans milk, evaporated, or 6 ounces
1 pound butter	powdered skim milk and 1½ pints
	water

Clean and peel the potatoes and boil them until thoroughly done. Drain, salt, and mash well. Heat milk and melt butter and add to the mashed potatoes and beat vigorously with a wire whip. Garnish with small quantity of chopped parsley. The potatoes may be fluffed by the addition of 1 tablespoonful of baking powder just before they are beaten with the wire whip. Serve hot.

192. Potatoes, sweet, baked

40 pounds potatoes, sweet	1 pound fat
---------------------------	-------------

Wash and trim all defective spots. Rub with fat and bake in a pan in a medium oven (325°-400° F.—12 to 16 counts) for 1 hour or until done. Serve hot in jacket with butter.

Do not pierce with fork to ascertain if done. When done, the potatoes are soft when pressed. This requires about 50 minutes.

193. Potatoes, sweet, boiled

40 pounds potatoes, sweet, unpeeled

Peel and trim all defective spots and wash. Boil 40 minutes or until tender, then drain. Serve hot.

194. Potatoes, sweet, candied

45 pounds potatoes, sweet, unpeeled	2 pounds sugar
1 pound butter	1 gallon beef stock, strained

Wash the potatoes and boil until medium done (about 20 minutes); then peel and slice them lengthwise. Spread the slices in three layers in a bakepan, putting about one-third of the sugar and butter on top of each layer; pour the beef stock over the whole and bake in a medium oven (325°-400° F.—12 to 16 counts) 40 minutes to 1 hour until well browned. Serve hot.

195. Potatoes, sweet, fried

45 pounds potatoes, sweet	5 pounds fat
---------------------------	--------------

Procedure same as for potatoes, french fried.

196. Pumpkin, baked

30 pounds pumpkin, fresh	2 pounds bacon drippings
--------------------------	--------------------------

Peel the pumpkin, remove the seeds, and clean well. Cut in pieces not more than 2 inches square. Spread the pieces in one layer in a bakepan and pour over them about 1 pound of bacon drippings.

pers in another pan until browned and tender, then add the minced tomatoes and fry slowly for another 10 minutes. Place the fried rice and bacon-onion-pepper-tomato mixture together in a boiler, add the chili powder, and pour on the beef stock. Simmer until the rice is tender. Serve hot alone or with meats.

201. Rice, steamed

7 pounds rice
2 gallons water

4 ounces salt

Wash the rice thoroughly in several waters. Bring the water to a boil, add the salt, sprinkle in the rice, and let boil for 5 minutes, then let cook at a simmering temperature for 45 minutes with the lid partly open so that the steam may escape. When stirring rice, always use a fork to avoid breaking the kernels.

202. Sauerkraut

4 gallons sauerkraut, or 4 cans
sauerkraut (No. 10 cans)

2½ gallons beef stock

Add the beef stock to the sauerkraut, season to taste, and simmer for about 1 hour. Serve hot.

203. Sauerkraut, how made

30 pounds cabbage, trimmed

1 pound salt

Remove outer green leaves and slice the cabbage fine. Place in a barrel a layer of cabbage (about 12 inches) and sprinkle salt over it, then mash with a wooden masher until mushy. Add other layers of cabbage and salt until the barrel is full. After the barrel is filled, cover the kraut with a clean cloth and then with a board prepared to fit snugly inside of the barrel. The board should be placed on the cloth and a 100-pound rock on the board while the cabbage is fermenting. Let stand in a temperature of about 70° F. for 1 month. If the kraut is made in warm weather, the amount of salt used must be increased by ½ pound. In warm weather the ripening process will be faster than in cold weather. When the kraut is ready for use it will have a decided odor, but when not fully matured it will have an odor somewhat resembling that of beer. The temperature of the place where it is stored has much to do with the acidity acquired in any given time. Each time when removing kraut from the barrel, thoroughly wash cloth, barrel cover, weigh, and sides of barrel, before replacing. This should be done once every week whether kraut is removed or not. Care should be exercised in the selection of a barrel

for sauerkraut. Charred barrels should not be used. Oak barrels are preferable.

204. Squash, baked

Prepare in the same manner as pumpkin, baked (recipe 196), substituting squash for pumpkin.

205. Squash, canned, baked

12 cans squash (No. 3 cans) or 4 1 pound fat
cans squash No. 10 cans)

Remove from the cans, season with salt, and place in a well-greased pan; spread evenly and add a small amount of fat; place in a medium oven (325°-400° F.—12 to 16 counts) and bake for ½ hour. Serve hot.

206. Squash, mashed

25 pounds squash, fresh 2 pounds bacon drippings
4 quarts beef stock

Peel the squash, remove the seeds, and clean well. Cut in pieces not more than 2 inches square, place in a boiler, and pour the beef stock over it. Season to taste with salt and pepper, close the boiler with a tight lid, and boil about 2 hours (or until well done). Add the bacon drippings and mash well before serving. Serve hot.

207. Succotash

2 cans corn (No. 10 cans) or 10 cans 2 pounds bacon, diced
corn (No. 2 cans) 2 quarts beef stock
1 can lima beans (No. 10 cans) or 1 pound flour
5 cans lima beans (No. 2 cans)

Mix the corn, beans, and bacon, season to taste with pepper and salt, and pour over the mixture sufficient beef stock to cover it. Simmer until hot (about 15 minutes), then thicken slightly with a flour batter and boil for 5 minutes more.

208. Tomatoes, stewed

30 pounds tomatoes, fresh, or 3 cans 5 pounds bread, dry
tomatoes (No. 10 cans) or 14 cans 1 pound butter (for flavoring, if de-
tomatoes (No. 3 cans) sired)

For *fresh tomatoes* place 8 or 10 tomatoes in a colander at a time and set in boiling water for about ½ minute. Peel and split them in halves and place in the stewpot. Simmer and add 4 quarts of strained beef stock, season to taste with pepper and salt, and add croutons made from dry bread.

If *canned tomatoes* are used, heat just long enough to be hot for serving (not over 15 minutes), season, and add croutons (and butter if used). Serve hot.

209. Turnips, boiled

25 pounds turnips

5 pounds bacon or salt pork

Peel turnips and cut crosswise into $\frac{1}{2}$ -inch slices. Add bacon or salt pork, pepper and salt to taste, and boil slowly 40 minutes or until done. Keep turnips completely covered with water and leave boiler uncovered in order that the sulfur may escape. Serve hot.

210. Turnips, mashed

Same as turnips, boiled, except the turnips are mashed before serving.

211. Turnips, left-over

May be used by baking in the oven until slightly browned while covered with a few strips of bacon or salt pork.

DESSERTS

212. Apples, baked

100 apples

$1\frac{1}{2}$ ounces cloves, ground

2 pounds sugar

$1\frac{1}{2}$ ounces nutmeg, ground

Select uniform-sized hard apples. Wash and remove the core. Place in a bakepan and sprinkle with the sugar and spice. Bake in a moderate oven (250° – 325° F.—16 to 18 counts) for about 1 hour or until tender. Serve hot or cold, with or without sweet milk or sauce.

213. Apple or fruit rolls

Dough

10 pounds flour

5 pounds lard

2 ounces salt

4 ounces sugar

Filler

25 pounds apples, fresh, or 7 pounds apples, dried, or 3 cans apples (No. 10 cans)

5 pounds sugar

3 ounces nutmeg

3 ounces cinnamon

$\frac{1}{2}$ pound butter

Prepare the dough and filler as for apple pie (recipes 244 and 245), stewing the apples rather dry to avoid soggy crust. Roll the dough about $\frac{1}{4}$ -inch thick into strips about 7 inches wide and a little longer than the width of the pan. Spread the apple filler moder-

ately thin over the dough and then roll like a cigarette. Do not use too great a proportion of filler to dough or the rolls will be soggy. Regulate width of dough so that the finished rolls are not over 3 inches thick. Place in pan seam side down and close together so that the rolls retain their shape. Bake about 40 minutes in a medium oven (325°-400° F.—12 to 16 counts) and serve hot or cold, with or without sauce. Any kind of stewed and spiced fruit may be substituted for the apples and the rolls named accordingly.

214. Apple sauce

8 pounds apples, evaporated, or 30 Sugar (varies with apples used), about
pounds apples, fresh, or 3 cans apples 5 pounds
(No. 10 cans) 6 lemons

If *evaporated apples* are used, place the apples in 3 gallons of cold water and bring to a boil, then simmer until tender, about 2 hours. Add sugar to taste and flavor with lemon extract or sliced lemons.

If *fresh apples* are used, peel, core, quarter, add sugar and lemons, and simmer until mushy.

If *canned apples* are used, add sugar and lemons and simmer until mushy. Serve cold.

215. Apricots, dried, stewed

10 pounds apricots, dried 6 lemons
5 pounds sugar

Wash apricots and then place in enough water to cover. Soak about 8 hours or overnight, then add sugar and juice of lemon and simmer for 45 minutes or until tender.

216. Brown betty

15 pounds bread or bread scraps 4 pounds currants or other dried tart
10 pounds sugar, caramelized fruit

Dice the bread into 1-inch cubes and brown in a slow oven. Add the caramelized sugar and the fruit to 5 gallons of water, thicken slightly with a flour batter, and pour over the diced bread. Bake in a medium oven (325°-400° F.—12 to 16 counts) about 20 minutes and serve with sauce.

217. Cake, chocolate

Same as for cake, white, with addition of 1 pound cocoa or 12 ounces melted plain chocolate. The cocoa or melted chocolate is added at the end of the mixing and thoroughly stirred in.

218. Cake, corn

9 pounds flour	30 eggs
6 pounds corn meal	8 ounces baking powder
7 pounds sugar	1 ounce extract
4 pounds fat (butter, lard, or lard substitute)	2½ ounces salt

Whip the sugar, fat, extract, and salt to a cream and beat in the eggs slowly. Sift together the flour, corn meal, and baking powder, and add to the creamed mixture with sufficient water to make a stiff batter. Bake in a medium oven (325°-400° F.—12 to 16 counts) for about 30 minutes. This cake may be made in different forms using muffin pans as well as bakepans. Serve hot with butter, jam, jelly, or sirup.

219. Cake, eggless

10¼ pounds flour	2¼ pounds fat (butter, lard, or lard substitute)
5¼ ounces baking powder	4 pounds fruit, dried, stewed, ground
3½ ounces cinnamon	10 quarts milk, fresh, or 10 cans milk, evaporated, diluted with 10 pints water.
2 ounces flavoring extract	
15 pounds sugar	

Cream the fat and sugar and flavoring extract. Sift together the flour, baking powder, and cinnamon three times and add this and the fruit to the creamed mixture with the milk. Water may be used in place of the milk, but does not make as good a cake. Stir well and bake about 40 minutes in a moderate oven (250°-325° F.—16 to 18 counts). Serve plain or iced. This recipe produces a fairly palatable cake which can be made from items included in the field ration, or when eggs are not available.

220. Cake, fruit, dark

8 ounces citron	½ ounce cloves, ground
8 ounces lemon peel	6 pounds flour
8 ounces orange peel	4½ pounds sugar
3 pounds raisins	4½ pounds fat (butter, lard, or lard substitute)
3 pounds currants	12 ounces molasses
3 pounds nuts, mixed, shelled	40 eggs
½ ounce nutmeg, ground	
½ ounce ginger, ground	

Slice citron, lemon, and orange peel very thin and about the size of a postage stamp, and wash. Pick the raisins, currants, and nuts over carefully and wash. Mix all the fruit and drain in a sieve for 2 hours, then dredge with a mixture of the nutmeg, ginger, cloves, cinnamon, and 1 pound of the flour. Cream the sugar, butter, and molasses and

beat in the eggs. Add the remaining flour. When the flour is about half mixed in the batter, add the dredged fruit and spices and continue mixing until the fruit is evenly distributed and the mixture smooth. This mixture makes 35 pounds of cake.

The best results are obtained by baking fruit cake in an earthen crock. If this is not available it may be baked in a pan. Fruit cake requires a long, slow process of baking. From 3 to 5 hours in a slow oven (200°-250° F.—18 to 20 counts) are required.

221. Cake, marble

Same ingredients as for cake, white, with added coloring. After the batter is mixed it should be divided into halves or thirds according to the number of colors desired. One portion should be left white, the other portion or portions should be colored as follows:

Chocolate.—Add 8 ounces cocoa or 6 ounces melted plain chocolate and stir well.

Pink, red, orange, etc.—These, or other desired colors, may be obtained by adding prepared commercial vegetable colorings until the desired color is reached.

After the different portions are colored they are combined, stirring only enough to make a pleasing combination of colors.

222. Cake, quick

4 pounds fat (butter, lard, or lard substitute)	30 eggs
12 pounds sugar, brown	7 pounds flour, soft
2 cans milk, evaporated, or 7 ounces powdered skim milk dissolved in 2 pints water	6 ounces baking powder
	½ ounce cinnamon, ground
	½ ounce nutmeg, ground

Put ingredients into a bowl and beat all together for 3 minutes. Regulate liquid to make a thick batter, adding water or milk if necessary. Bake in a medium oven (325°-400° F.—12 to 16 counts) for 40 minutes, or until done. Serve plain or with icing. The batter may be used for cupcakes.

223. Cake, raised

4 pounds yeast-raised dough (recipe 264)	3 pounds flour
2½ pounds fat (butter, lard, or lard substitute)	3 ounces nutmeg
4½ pounds sugar	3 ounces cinnamon
18 eggs	1 ounce cloves
	3 pounds raisins

Take the dough when it is ready to punch down the first time and add to it the fat and sugar, and mix well. Then add the eggs, one at a

time, working them into the dough. Sift the flour, cinnamon, cloves, and nutmeg together and add to the mixture. Mix or knead thoroughly, put in a bakepan, and set aside for about 1 hour, preferably in a temperature of 80° F. At the end of this time, the cake should be light and about double in height. Bake in a medium oven (325°-400° F.—12 to 16 counts) for about 30 minutes, or until done. Cool before removing from the pan. This cake will be improved in appearance and flavor by icing.

224. Cake, spice

2½ pounds fat (butter, lard, or lard substitute)	6 pounds flour, soft
7 pounds sugar	4 ounces baking powder
40 egg yolks	1 ounce salt
20 egg whites	2 ounces cinnamon, ground
5 cans milk, evaporated, or 1 pound powdered milk dissolved in 4 pints water	1 ounce cloves, ground
	1 ounce allspice, ground
	1 ounce nutmeg, ground

Cream the fat and sugar. Beat the egg yolk with the creamed fat and sugar. Moisten the spices with 1 pint boiling water and beat into the creamed fat-sugar-egg mixture. Sift together the flour, baking powder, and salt three times, and add gradually, with the milk, to the creamed mixture in such proportions as to make mixing easy. Beat the egg whites until stiff, and fold carefully into the batter. Bake in a medium oven (352°-400° F.—12 to 16 counts) for 40 minutes if made in the form of a loaf cake, or 25 minutes if made into cupcakes. Keep the oven as near 375° F, as possible throughout the baking. Serve plain or with icing.

225. Cake, sponge

2½ pounds flour, soft	4 tablespoonfuls cream of tartar
5½ pounds sugar	½ cup water, boiling
60 eggs	3 tablespoonfuls vanilla extract
3 teaspoonfuls salt	

Weigh the flour, and sift three times with one-half of the sugar. Separate the eggs and beat the yolks. Add the remaining sugar to the yolks, and beat well to thoroughly mix. Add the boiling water, beating continuously. Add the flour-and-sugar mixture slowly and mix thoroughly. Sift the salt and cream of tartar over the egg whites and beat until the whites are stiff. Add the extract to the whites and mix with the yolk mixture. Bake for 1 hour at 300° F., on lowest shelf or rack in the oven; avoid top heat. Remove from the oven and turn the pan upside down until the cake is cool. This may be served with fruit as a shortcake.

226. Cake, white

7 pounds sugar	10 ounces baking powder
3½ pounds fat (butter, lard, or lard substitute)	2 ounces salt
24 eggs	4 cans milk, evaporated, or 13 ounces powdered skim milk dissolved in 3 pints water
2¼ ounces flavoring extract	
13½ pounds flour	

Cream together the sugar, fat, eggs, and flavoring extract, adding one ingredient at a time in the order given. The flour, baking powder, and salt should be sifted together twice and added gradually. Add a part of the milk from time to time as needed to make the mixing easy. If mixed in a mechanical mixer, the beating operation should be at second speed. When all the milk is added there should be a stiff batter. If too stiff, more milk or water may be added. This may be baked in round pans for layer cake or in large pans for shortcake. If used for layer cake use two to four layers to form a cake when cool enough to handle and spread any desired filling between layers. Cover top and sides with same filling or an icing. If baked in sheet form, it may be made into layer cake or served plain or with a sweet sauce. This may also be made into cupcakes.

227. Cobbler, apple or fruit

Filler

Crust

7 pounds apples, evaporated, or 25 pounds apples, fresh, or 3 cans apples (No. 10 cans)	14 pounds flour
4½ pounds sugar	7 ounces baking powder
2 ounces cinnamon	2 pounds lard
1 ounce nutmeg	2 pounds sugar
3 lemons, sliced thin	27 eggs
	2½ ounces salt
	2 quarts water

If evaporated apples are used, wash the apples thoroughly and soak them in cold water for 2 hours, then cook them in 2½ gallons water until well done, but not broken. Cool them and add the sugar, spices, and sliced lemon.

If fresh apples are used, peel, core, and cut into eighths. Cook in a pan with sugar, sliced lemons, and spices until medium soft but not mushy. Avoid stirring as this breaks the apples.

If canned apples are used, cook as for fresh apples, but less cooking is required.

Crust.—Cream the sugar, lard, and salt thoroughly, then add the eggs, one at a time, stirring constantly. Pour in the water and mix well. Sift the flour and baking powder together several times, then

add them to the mixture and work until smooth. Take about two-thirds of the dough and roll out $\frac{1}{2}$ inch thick. Line two bakepans with a bottom crust and bake in a medium oven (325° – 400° F.—12 to 16 counts) for 20 minutes. When baked, cover both crusts in pans with spiced apples about $\frac{1}{2}$ inch thick. Roll out the remainder of the dough and cover the contents of both pans, tucking the sides down well. Bake for 20 minutes in a medium oven. Serve hot with a sweet sauce of any flavor.

Other fruits, fresh, canned, or dried (peaches, apricots, prunes, etc.), may be substituted for the apples, and the cobbler named accordingly.

228. Crullers

10 ounces fat (butter, lard, or lard substitute)	5 pounds flour
$1\frac{1}{4}$ pounds sugar	$2\frac{1}{2}$ ounces baking powder
10 eggs	$1\frac{1}{4}$ pints water
$\frac{1}{2}$ ounce flavoring extract	8 pounds fat (for deep frying)

Cream butter and sugar together, and add the extract. Beat the eggs well, then beat into the creamed mixture. Sift the baking powder and flour together and add to the mixture. Add the water, and stir until the dough is smooth. Roll out the dough to a thickness of $\frac{1}{2}$ inch and cut with a doughnut cutter. Fry a golden brown in deep fat. Remove, drain, and roll in granulated sugar, or place on a plate and dust with powdered sugar.

229. Custard, egg

2 gallons milk, fresh, or 8 cans milk, evaporated, diluted with 8 pints water, or 26 ounces powdered skim milk dissolved in 9 pints water	40 eggs
	2 ounces salt
	24 ounces sugar
	2 ounces flavoring extract

Beat all ingredients to a foam and pour into a well-greased bakepan. Bake in a medium oven (325° – 400° F.—12 to 16 counts) for 20 to 30 minutes, or until done. When done a silver knife stuck in the custard will come out clean. If baked too long it will become watery. Any flavoring may be used. Serve cold.

230. Fritters, oatmeal

2 gallons oatmeal mush (recipe 10)	1 pound flour
2 pounds sugar	8 pounds fat (for frying)
12 ounces baking powder	

Mix all ingredients except fat to make a stiff batter. With a tablespoon cut pieces about half the size of an egg and fry, until a golden brown, in deep fat. Remove from the fat with a skimmer,

and drain. Dust with powdered sugar or serve with sirup. To improve this recipe, add six eggs and a few drops of flavoring extract to each gallon of mush. Serve hot.

231. Fruits, dried, stewed

See: Apple sauce (recipe 214).

Apricots, dried, stewed (recipe 215).

Peaches, dried, stewed (recipe 243).

Prunes, stewed (recipe 253).

232. Gelatin

8 ounces gelatin, powdered	10 to 15 quarts water (dependent on
5 ounces sugar	brand of gelatin used—follow di-
¾ ounce flavoring extract	rections on package)

Soak the gelatin in ½ pint of cold water for 10 minutes. Bring the remainder of the water to a boil, stir in the soaked gelatin until dissolved, and then stir in the sugar. Cool the mixture and stir in the flavoring extract. Pour into a mold which has been rinsed in cold water. Let stand until it jells. It is then ready to serve. The lower the temperature in which set, the quicker the gelatin will jell. At 50° F. it will jell in 2 hours, while at 80° F. it will jell in 6 hours. Addition of various fruits, after cooling and before jelling, improves and enriches the dish. Fruit juices may be used for color and flavor. To remove from mold, set the mold in warm water for a few seconds.

233. Ice cream

½ pound flour or cornstarch	12 quarts milk, fresh, or 12 cans milk,
5 pounds sugar	evaporated and 12 pints water
½ teaspoon salt	1 pint cream, thin
24 eggs	2 teaspoonfuls vanilla extract

Mix flour, sugar, and salt. Add eggs (slightly beaten) and milk, gradually. Cook in double boiler (over hot water) about 20 minutes, stirring constantly at first. If the custard has a curdled appearance this will disappear in freezing. When cool add cream and flavoring extract and freeze. Any flavoring extract may be used for flavor in place of vanilla, or any fruit may be added for flavor and additional richness. This ice cream may be used as a base for chocolate ice cream, coffee ice cream, strawberry ice cream, etc.

234. Ice cream, chocolate

4 gallons basic ice cream mixture	12 ounces cocoa or 8 ounces chocolate
	melted

beating continuously. Add the flavoring, mix well, and spread on cakes quickly. If not used immediately, it will harden and cannot be spread. Ten ounces of cocoa or 6 ounces of melted chocolate may be added to the sugar and water during cooking instead of the flavoring.

240. Icing, uncooked, for cakes

4 pounds powdered sugar	$\frac{1}{2}$ pound vegetable shortening or but-
1 pint cold water	ter (do not use lard)
3 tablespoonfuls vanilla extract	

Mix the sugar with cold water until of spreading consistency. Add the flavoring extract and shortening and mix well. Spread on cakes and let stand 30 minutes before serving.

Chocolate icing may be made by adding 10 ounces of cocoa or 6 ounces of melted chocolate with the sugar before adding the water. If chocolate is added, do not use any flavoring extract.

Any flavoring extract may be used for flavoring instead of vanilla, using 2 tablespoonfuls instead of 3 tablespoonfuls of vanilla.

241. Meringue

(For 17 pies, 9-inch)

34 egg whites	1 pound sugar
1 ounce salt	$\frac{1}{2}$ ounce vanilla extract

Beat the egg whites until they are foamy and white in appearance and stiff enough to hold their shape. Sprinkle sugar over the beaten whites and continue beating until the mixture is stiff enough to hold in peaks. During the beating add the salt and extract. Spread over pie filling with the aid of a smooth knife and brown on upper shelf of a quick oven (400° - 450° F.—9 to 12 counts). This requires about 15 minutes.

242. Mincemeat

$1\frac{1}{4}$ pounds beef, fresh (cooked) or corned beef	$\frac{1}{4}$ ounce black pepper, ground
$1\frac{1}{4}$ pounds suet	$2\frac{1}{2}$ pounds sugar
5 pounds apples, dried	$\frac{1}{4}$ pound salt
$2\frac{1}{2}$ pounds peaches, dried	$1\frac{1}{4}$ pounds currants
$2\frac{1}{2}$ pounds prunes, seeded	4 pounds raisins
$\frac{1}{4}$ pound cinnamon, ground	$\frac{1}{2}$ pound candied citron
1 ounce cloves, ground	$\frac{1}{4}$ pound lemon peel
	$\frac{1}{4}$ pound orange peel

Soak the dried fruit in cold water for 1 hour, then drain, and run the beef, suet, apples, peaches, and prunes through a meat grinder.

Then mix all the ingredients with only sufficient water to moisten and pack in a clean container, preferably a wooden keg. This mixture will keep well when kept free from water. Five pounds of this mixture will make 15 pies.

243. Peaches, dried, stewed

7 pounds peaches, dried 4 lemons
3 pounds sugar

Wash peaches and place in enough water to cover. Soak about 8 hours or overnight, then add sugar and juice of lemons and simmer for 45 minutes or until tender.

244. Pie crust

(Makes 3 double 9-inch crusts)

1 pound flour $\frac{1}{5}$ ounce salt
8 ounces fat (lard or lard substitute) $\frac{1}{4}$ pint cold water

All ingredients should be thoroughly chilled before using.

Mix the flour with one-half the fat by chopping or cutting with a food chopper or knife until the size of corn meal. Then mix in the remainder of the fat by the same method, except that the fat is cut in so as to leave the mixture in small pieces, about the size of a bean, then add the cold water slowly while tossing the mixture with a fork. A medium-soft dough, not slack or stiff, is easiest to handle. Roll and handle as little as possible.

Best results will be had by making up pie crust dough in small batches like this recipe for three pies.

245. Pie, apple or fruit

35 pounds apples, fresh, or 7 pounds 3 pounds sugar
apples, evaporated, or 3 cans apples 3 lemons
(No. 10 cans) $\frac{3}{4}$ ounce cinnamon

Fresh apples.—Peel, core, and cut into eighths. Add sugar, lemon, and cinnamon, and cook in a pan until medium soft, but not mushy. Avoid unnecessary stirring which breaks the apples.

Evaporated apples.—Soak overnight or about 8 hours in cold water. Cook as for fresh apples.

Canned apples.—Put into pie crust, add sugar, lemon, and cinnamon, then bake.

The quantity of sugar and spices used in the stew will have to be increased or decreased depending upon the tartness of the apples. Make the pies with double crust and bake about 40 minutes in a

quick oven (400°-450° F.—9 to 12 counts). Many fruits may be substituted for the apples, as apricots, peaches, cherries, pineapples, etc.

This recipe is sufficient for about 17 pies.

246. Pie, banana cream

Filling.—Same as for coconut cream pie except that instead of the coconut, 10 pounds of sliced bananas are added after the filling has cooled. If the bananas are added while the filling is hot, they will turn black.

247. Pie, chocolate, meringue

Filling (17 pies)

17 ounces chocolate, plain	1½ ounces salt
6 quarts milk, fresh, or 6 cans milk, evaporated, diluted with 6 pints water, or 40 ounces powdered skim milk dissolved in 9 pints water	34 egg yolks
	6 ounces butter
	1 ounce vanilla extract
	5 pounds sugar
1 pound flour	

Melt chocolate in double boiler, add sugar, flour, and salt, and stir. Heat milk, but not to boiling point, stirring frequently to prevent scorching. When hot, stir gradually into the mixture. Cook the mixture about 15 minutes, stirring constantly until it thickens. Cover double boiler and set on back of stove. Beat egg yolks lightly, and stir about one-fourth of the hot mixture with the yolks. Return to double boiler and cook about 2 minutes. Add butter and vanilla and beat until smooth.

After the pie crust has been baked, fill with the chocolate mixture, cover with a meringue, and brown on upper shelf of quick oven (400°-450° F.—9 to 12 counts).

248. Pie, coconut cream

Filling

1 pound flour	6 quarts milk, fresh, or 6 cans milk, evaporated, diluted with 6 pints water, or 40 ounces powdered skim milk dissolved in 9 pints water
3¾ pounds sugar	
36 eggs	5 pounds coconut, shredded
1 ounce vanilla extract	

Separate egg whites and yolks and beat yolks lightly. Mix flour and sugar. Heat milk, stir about one-fourth into flour-sugar mixture, and beat until smooth. Add egg yolks and mix well. Add remainder of milk gradually with constant stirring. Put in double boiler and cook for about 15 minutes, then add coconut and extract and pour into baked pie shell; place filled pie shell in oven for

about 10 minutes. Meringue may be added before the pie is put into the oven. Do not cut this pie until time to serve. Serve on the day it is prepared.

249. Pie, custard

Filling

3½ pounds sugar	36 eggs
12 quarts milk, fresh, or 6 cans milk,	12 ounces cornstarch
evaporated, diluted with 6 pints	½ ounce vanilla extract
water	Pinch of nutmeg or mace, ground

Beat the sugar and eggs until the sugar is well dissolved. Add the milk, saving enough to dissolve the cornstarch. Add the dissolved cornstarch and flavoring. Mix.

250. Pie, lemon cream

Filling (17 pies)

1 pound flour	6 quarts milk, fresh, or 6 cans milk,
5½ pounds sugar	evaporated, diluted with 6 pints
48 eggs	water, or 40 ounces powdered skim
17 lemons	milk dissolved in 9 pints water

Mix flour and sugar. Beat eggs and mix with flour and sugar. Grate lemon rinds, squeeze lemon juice, and add grated rinds and juice to mixture. Stir milk into mixture slowly to prevent lumping. Cook mixture in double boiler for 15 minutes, stirring constantly until it thickens, then remove from the fire and beat until smooth. Pour into pie shells which have been baked to a light brown. Place the filled pie shells (with meringue) on upper shelf of quick oven (400°-450° F.—9 to 12 counts) for about 10 minutes.

251. Pie, mince

For each pie use ⅓ pound of mincemeat and ⅔ pound of liquid. The liquid may be either sugar, sirup, molasses, or cider. Mix the mincemeat and liquid thoroughly and use a double pie crust. Bake about 30 minutes in a quick oven (400°-450° F.—9 to 12 counts).

252. Pie, pumpkin or squash

Filling (17 pies)

12 pounds pumpkin or squash, fresh,	3 ounces ginger, ground
or 3 cans pumpkin (No. 10 cans) or 7	5 quarts milk, fresh, or 5 cans milk,
cans pumpkin (No. 3 cans)	evaporated, diluted with 5 pints
6½ pounds sugar, brown or white	water, or 1 pound powdered skim
1½ ounces salt	milk dissolved in 8 pints water
34 eggs	3 ounces cinnamon or cloves

If fresh pumpkin or squash is used, prepare and cook as in squash, mashed; if canned, cooking is not necessary. Place cooked or canned pumpkin or squash in a large bowl or container. The pumpkin or squash must be smooth but not watery (if watery, heat until water has evaporated). Mix sugar, salt, spices, and milk with the pumpkin or squash. Beat the eggs and stir into the mixture and pour into unbaked pie shells. Bake in a quick oven (400°-450° F.—9 to 12 counts) for the first 20 minutes, then lower to a slow oven (200°-250° F.—18 to 20 counts) and continue for 40 minutes longer. When completely baked, the filling is firm and does not stick to a knife blade, and the edge of the crust is a golden brown. If the filling shrinks unduly, it was too moist.

253. Prunes, stewed

7 pounds prunes
3 pounds sugar

3 lemons, sliced thin

Wash prunes. Cover with cold water; bring to a boil and cook until tender (30 to 50 minutes). Add sugar and lemon for last 5 minutes of cooking. Remove from fire; add water to replace that which has evaporated. Let stand overnight. Serve cold.

254. Pudding, apple

7 pounds apples, dried, soaked, and 26 pounds bread (may be dry) stewed, or 25 pounds of fresh apples, 7 pounds sugar
stewed and diced or 2 cans apples 4 ounces cinnamon
(No. 10 cans)

Slice and toast the bread and spread in the bottom of a well-greased bakepan, then spread a layer of the apples over the toast and sprinkle with sugar and cinnamon; continue alternate layers of toast and apples until the pan is filled. Bake in a medium oven (325°-400° F.—12 to 16 counts) about 20 minutes and serve with a plain or caramel sauce. Nearly any kind of fresh or dried fruit may be used and the pudding named accordingly.

255. Pudding, banana

10 pounds bananas
6 pounds sugar
3 pints milk
1 ounce salt
7 gallons water

12 eggs
4 pounds cornstarch
1 ounce vanilla flavoring
½ ounce lemon flavoring
½ pound butter

Put 6 gallons of water into a boiler. Add the sugar, salt, and milk. Bring to a boil. Dissolve the cornstarch thoroughly with 1 gallon of cold water. When the mixture reaches the boiling point,

pour the dissolved cornstarch in slowly, stirring continually. Let it cook at a simmering temperature until thickened. Remove from the fire, and when partly cooled add the flavoring, beaten eggs, and crushed bananas. Pour into pans and let cool.

256. Pudding, bread, with sauce

20 pounds bread crusts or dry bread	12 eggs
4 pounds fruit, fresh, dried, or canned	4 cans milk, evaporated, or 4 quarts
4 pounds sugar	milk, fresh, or 1 pound powdered
2 ounces cinnamon	skim milk dissolved in 3½ pints
4 pounds raisins	water

Soak the bread in the milk. Season with sugar and cinnamon, add raisins and beaten eggs, mix, and spread about 1 inch deep in pan. Over this spread about 1 inch of fruit stewed (if dried) then another layer of the bread mixture. Sprinkle sugar and cinnamon over the top layer. Bake about 40 minutes in a medium oven (325°-400° F.—12 to 16 counts). Serve hot or cold with cream or sweet sauce. This makes an excellent dish and gives an opportunity to use available scrap bread. Shredded coconut may be used to improve the flavor.

257. Pudding, cornstarch

7 pounds sugar	7 cans milk, evaporated, or 7 quarts
1½ ounces salt	milk, fresh, or 1½ pounds powdered
5 pounds cornstarch	skim milk dissolved in 5½ pints
1½ ounces flavoring extract	water

Dissolve the cornstarch in 5 quarts of cold water, then add 5 gallons of boiling water, the sugar, salt, and milk. Cook for 5 minutes, cool, and add the extract. This pudding is improved by dissolving the cornstarch in 5 quarts of milk instead of cold water and the addition of four eggs to each gallon of pudding made. It should never be served plain; various fruits, coconut, etc., should be added. Pour into vegetable dishes and when cool place in the ice box. Serve with milk or sweet sauce.

258. Pudding, indian, baked

4 pounds corn meal	½ pound butter
2 pounds flour	2 gallons water, boiling
1 quart molasses	½ ounce cinnamon
4 cans milk, evaporated, diluted with 4 pints water	1 ounce ginger

Mix the molasses and corn meal together and pour over the boiling water. Add the butter, salt, and spices. When the mixture is cool,

Public Domain, Google-digitized / http://www.natnitrust.org/access_use#pd-googole

pour the milk over, but do not stir into the pudding. Bake in a slow oven (200°-250° F.—16 to 18 counts) from 2 to 3 hours. Take care that it does not burn. Serve hot.

259. Pudding, plum

10 pounds flour	½ ounce cloves, ground
6 ounces baking powder	2 ounces cinnamon, ground
2½ ounces salt	½ ounce nutmeg, ground
5 pounds beef suet, chopped fine	4 pounds sugar
5 pounds fruit, dried, stewed, and chopped fine	

Mix the flour, baking powder, salt, beef suet, stewed fruit, and spices in the order named. Dissolve the sugar in water and add it to the mixture, together with sufficient cold water to make a stiff dough. Fill 5-pound lard pails or pudding cans two-thirds full of the mixture. If no lids are available, tie a cloth tightly over the top of each pail or can. Place in a boiler containing sufficient boiling water to reach the height of one-third the pails or cans and maintain the water at the same level during cooking. Boil for 8 hours. Remove from the cans and split the pudding lengthwise through the center. Serve hot with plum pudding sauce.

260. Pudding, rice

9 pounds rice	5 cans milk, evaporated, diluted with
24 eggs	5 pints water, or 5 quarts fresh milk
4 pounds raisins	or 1 pound powdered skim milk dissolved in 4 pints water
9 pounds sugar	½ ounce flavoring extract
1 ounce salt	

Boil the rice for 15 minutes and drain. The rice should not be overboiled, as the kernels should remain separate and firm. Mix the eggs, raisins, sugar, milk, salt, and extract. Add rice and sufficient water to cover, and stir. Bake slowly in a moderate oven (250°-325° F.—16 to 18 counts) until slightly brown. Serve with cold or hot sweet sauce.

261. Pudding, rice and apple

30 pounds apples	5 pounds rice
½ pound butter	4 pounds sugar
1 ounce cinnamon	6 eggs
3 cans milk, evaporated, diluted with	1 gallon water
3 pints water	

Peel and cut the apples into small pieces. Cook the rice until tender and then drain off the water. Line the bottom of pans with cooked rice, then a layer of apples. Cream butter, sugar, and spice. Then

add eggs (beaten), water, and milk. Pour the mixture over the rice and apples. Bake in a medium oven (325°-400° F.—12 to 16 counts) for 30 minutes. Serve with milk or sweet sauce.

262. Pudding, sweet potato

40 pounds sweet potatoes	2 cans milk, evaporated
3 pounds sugar	1 ounce lemon flavoring or ½ pint
18 eggs	lemon juice

Wash and cover sweet potatoes with clean water, bring to a boil, and let cook slowly for 40 minutes or until tender. Drain off the water. When cooled, peel and put them through the meat chopper. Separate the egg yolks from the whites; add the egg yolks to the potatoes, then the sugar, milk, and flavoring or lemon juice. Mix it thoroughly and place in buttered or greased pans. Beat the egg whites until stiff and spread over the pudding. Bake in a medium oven (325°-400° F.—12 to 16 counts) until browned.

263. Pudding, tapioca

4 pounds tapioca	4 pounds fruit, dried, stewed, and
4 gallons water, cold	chopped
7 pounds sugar	18 eggs
	1 ounce flavoring extract

Soak the tapioca 2 hours in sufficient cold water to cover; then simmer until clear (until the "pearls" have disappeared) which will require about 1 hour; then beat or whip in the fruit, sugar, beaten eggs, and extract while hot. Raisins, currants, or other fruit may be added.

If quick (granulated) tapioca is used, no soaking is required. Add tapioca to cold water and bring to the simmering point. In about 15 or 20 minutes the granules of tapioca will have disappeared. Then add other ingredients as shown for pearl tapioca.

Serve hot or cold with milk or a sweet sauce.

SWEET DOUGH PRODUCTS

264. Basic sweet dough

2 pounds flour, soft (pastry)	1¼ ounces salt
6½ pounds flour, hard (issue)	1 pound fat (lard or lard substitute)
2 quarts milk, or water, or 2 cans milk,	8 eggs
evaporated, diluted with 2 pints water	¼ ounce mace or nutmeg
½ pound yeast, compressed, or 1½	¼ ounce lemon extract or 4 lemons
pounds yeast, dried	grated, rind and all
1 pound sugar	

This recipe produces one basic sweet dough and provides sufficient dough to make about 225 buns, doughnuts, etc., or an equivalent quan-

tity of coffee cake, etc. Therefore, one basic sweet dough is sufficient for 100 men. For 200 men, use two basic sweet doughs; for 50 men use one-half of one basic sweet dough, etc.

Straight-dough method.—Cream thoroughly the sugar, salt, fat, and spice, then add eggs gradually and cream until light. Add flavoring extract. Dissolve the yeast in one-fourth of the milk which should be at a temperature of about 80° F. Add remainder of milk to the creamed mass and stir thoroughly to dissolve all ingredients. Add hard flour and begin mixing. Pour on yeast solution, add soft flour, and continue mixing until the dough is smooth and free from lumps. This dough should be slacker than ordinary bread dough. Regulate water or milk to have a dough not too slack to handle. Set to rise in temperature of about 80° F. and cover with cloth. Allow to ferment (rise) until dough around impressions made by moderate pressure of two fingers starts to recede, then give first punch. The first rise requires about 1½ hours. In hot weather, or when it is impossible to keep the temperature of the dough down to 80° F., it is best to punch the dough young, about 45 minutes after mixing, as overfermentation ruins sweet dough more than any other factor. After punching, allow to stand 15 or 20 minutes, then work into desired forms. Cover dough not being worked to prevent crusting.

Comments.—The addition of 4 ounces of baker's malt, when available, to the above ingredients will improve the dough. All hard flour may be used if soft flour is not available. In such case substitute 1½ pounds cornstarch for an equal amount of flour.

This is a yeast-raised dough to which additional sugar may be added after fermentation. It is usually enriched by the addition of eggs, spices, butter, citron, lemon peel, raisins, nuts, etc., and is manipulated into desired forms. It may be made by the straight-dough or sponge methods. The sponge method (given below) is used when speed is essential.

If the dough must be handled in a cold room, some means should be found to keep the temperature around 80° F. The dough may be placed in a suitable vessel and this vessel placed in a fireless cooker or into a larger container lined with sacks or hay. Close the top of larger container and keep in a warm place, if possible.

At least 50 different forms of cakes, rolls, buns, etc., may be made from this sweet dough. This is done by taking the desired quantity of the sweet dough for the product to be made, adding such additional quantities of sugar, butter, eggs, fruits, citron, lemon peel, nuts, etc., as desired for richness, and working into desired form.

Quick sponge method.—Dissolve all the yeast (½ pound) in 1 pint of the liquid. Dissolve all the sugar (1 pound) in 1 pint of the liquid.

Pour the dissolved yeast over 3 pounds of the hard flour and mix slightly. Pour the dissolved sugar into the mixture and mix well. Set to stand in a warm place (about 90° F.). This will become spongy in about 20 minutes, hence the name "sponge." As soon as it has become light and spongy, put it into a mixing bowl, add remainder of liquid, and stir well to break up the sponge. Then cream the salt, fat, spice, and eggs, and add flavoring extract as for the straight-dough method. Add the cream mixture and stir well, then add remainder of flour and mix thoroughly. Allow to rest about 5 minutes and then commence working into the desired form.

265. Cake, apple

15 pounds apples, fresh, or 2 cans ap- ples (No. 10 cans)	1 pound fat (butter, lard, or lard sub- stitute)
1 basic sweet dough	1 pound raisins
1 pound sugar	

Make in the same manner as coffee cake but place thin slices of cooked, fresh, or canned apples over top of dough about 30 minutes before baking. Sprinkle with sugar and cinnamon, and raisins if desired, and bake in medium oven (325°-400° F.—12 to 16 counts) about 30 minutes. Avoid too much heat, as this may cause the fruit to become dry, or very ripe fruit to become mushy. Almost any kind of fruit may be used instead of apples. Bring edges of dough up around the side of the pan so as to retain fruit juice.

266. Cake, coffee

1 basic sweet dough	1 pound fat (butter, lard, or lard sub- stitute)
1 pound sugar	1 pound raisins

Work all other ingredients thoroughly into the sweet dough, roll out about ½ inch thick, and place in any kind of pan available. Allow to rise at 80° F. for about 30 minutes, or until the dough has about doubled in size. Bake in medium oven (325°-400° F.—12 to 16 counts) 20 to 30 minutes, or until done. To determine when baked, raise edge to see whether under side is done. After baking, cool and add plain icing or, instead of icing, sprinkle top with sugar and cinnamon just before placing in oven.

267. Doughnuts

1 basic sweet dough	½ ounce mace, ground
3 pounds flour	½ ounce lemon extract
½ ounce salt	Water sufficient to make a slack dough
3 ounces yeast compressed	

Mix all other ingredients with the basic sweet dough, then let rise for 20 minutes in a temperature of 80° F. Roll out into sheets about ½ inch thick and cut with doughnut cutter or form into various shapes as desired. Let rise again until about double in size, and fry in deep fat at 365° to 370° F. Too stiff a mixture may cause the doughnuts to crack while frying.

After frying, drain and sprinkle with powdered sugar mixed with a small quantity of cinnamon. Icing may be used.

268. Doughnuts, jelly

- | | |
|--------------------------|--|
| 1 can jelly (No. 10 can) | 3 ounces yeast, compressed |
| 1 basic sweet dough | ½ ounce mace, ground |
| 3 pounds flour | ½ ounce lemon extract |
| ½ ounce salt | Water sufficient to make a slack dough |

Same as for doughnuts but instead of cutting into doughnut shape, cut off pieces of dough about 1½ ounces in weight and roll into a ball. Make depression with thumb or any suitable instrument, drop small quantity of jelly into this depression, and close by pinching dough together. Let rise (or proof) about 30 minutes, then fry and sugar in the same manner as for doughnuts.

269. Rolls, cinnamon

- | | |
|---------------------|--|
| 1 basic sweet dough | 1 pound fat (butter, lard, or lard substitute) |
| ½ pound sugar | 6 ounces cinnamon |

Roll the basic dough into sheets about ¼ inch thick, 15 inches wide, and convenient lengths. Brush with melted fat and sprinkle liberally with sugar and cinnamon. Roll the sheet dough into a tight roll as a cigarette and cut into ½-inch thick slices with a sharp knife. Place close together in well-greased pans with cut sides, which have first been sprinkled with sugar, up and down. Let rise until double in size and bake in a medium oven (325°-400° F.—12 to 16 counts) 30 to 40 minutes. Do not bake until hard. Move bakepans occasionally while in the oven to insure being well baked on bottom. Turn out of pans to prevent sticking. When cool, cover with uncooked icing if desired.

270. Rolls, parkerhouse

- | | |
|---------------------|---------------------------------------|
| 1 basic sweet dough | ½ pound fat (lard or lard substitute) |
|---------------------|---------------------------------------|

Procedure same as for parkerhouse rolls (recipe 282).

Public Domain, Google-digitized / http://www.naturhistorisch-museum-wien.ac.at/

271. Stollen

1 basic sweet dough	2 pounds raisins
1 pound fat (butter, lard, or lard substitute)	½ pound citron
2 pounds sugar	2 cans pineapple (No. 2½ cans) diced and drained
12 eggs	

Work all other ingredients thoroughly into the sweet dough. Take 10 ounces of dough and roll into a piece 8 by 10 inches, rolling the half nearest the operator ½ inch thick and the half away from the operator 1 inch thick, so that by folding away from the operator the upper fold is thinner. Space in bakepans 2 inches apart. Let rise for about 30 minutes. Bake about 40 minutes in medium oven (325°-400° F.—12 to 16 counts). Other fruits may be added if desired. After cooling, ice with uncooked icing.

HOT BREADS

272. Biscuit, baking powder

16 pounds flour	6 cans milk, evaporated, diluted with
3 ounces salt	6 pints water, or 20 ounces powdered
11 ounces baking powder	skim milk dissolved in 6 pints water
4 pounds fat (lard or lard substitute)	

Sift the dry ingredients together three times and work in the fat. Make a well in the middle and add all the milk at once. Stir until mixed. This should make a soft dough, if not, add more milk. Turn out on lightly floured board and knead quickly for not more than 1 minute. The secret of making good biscuit is in handling the dough only enough to mix thoroughly. Roll out to one-half the thickness desired in the baked biscuit, cut out with a biscuit cutter, and place in bakepans just touching each other. Bake in a quick oven (400°-450° F.—9 to 12 counts) for 12 minutes or until brown. Serve hot.

273. Biscuit, cheese

Use the same recipe as for baking powder biscuit, adding 3 pounds of finely chopped American cheese. Mix same as for the baking powder biscuits except that the cheese is added with the milk and thoroughly stirred in.

274. Biscuit, sour milk

8¼ pounds flour	2⅔ ounces baking powder
1¼ ounces baking soda	1 ounce salt
1½ pounds fat (lard or lard substitute)	3¼ quarts milk, sour

Mix and sift dry ingredients. Work the fat into the flour mixture. Make a well in the middle and add all the milk at once. Stir until mixed. This should make a soft dough, if not, add more milk. Handle dough only enough to mix thoroughly. Roll out to one-half the thickness desired in the baked biscuit, cut out with a biscuit cutter, and place in a bakepan just touching each other. Bake in a quick oven (400°-450° F.—9 to 12 counts) for 12 minutes or until brown. Serve hot.

275. Corn bread

9½ pounds corn meal, white or yellow	½ pound fat (lard or lard substitute)
2¼ pounds flour	20 eggs
3 ounces baking powder	4 cans milk, evaporated, diluted with
3 ounces salt	4 pints water

Sift together corn meal, flour, salt, and baking powder. Work in the fat, add beaten eggs and milk, and mix well. Pour into a well-greased, heated pan and bake 20 minutes in a quick oven (400°-450° F.—9 to 12 counts). Cut into squares and serve hot. This may also be baked as muffins in muffin tins.

276. Corn bread (sour milk)

9½ pounds corn meal, white or yellow	3 ounces salt
1 gallon milk, sour	40 eggs
3 ounces soda	¾ pound fat (lard or lard substitute)

Sift together corn meal and salt. Work in the fat. Dissolve soda in ¼ cup water. Add, with the milk and beaten eggs, to the mixture. Mix well and pour into a well-greased, heated bakepan. Bake about 20 minutes in a quick oven (400°-450° F.—12 to 16 counts). Cut into squares and serve hot. This may also be baked as muffins in muffin tins.

277. Gingerbread

21 ounces sugar	21 ounces fat (lard or lard substitute)
10 eggs	2½ pints molasses
2½ pints milk	2¾ ounces soda
¼ ounce cinnamon	2 ounces ginger
6 pounds flour	

Cream sugar, shortening, and spices. Add the eggs gradually, then add soda dissolved in molasses and milk. Mix thoroughly. Fold in flour. Grease pans. Bake in a medium oven (325°-400° F.—12 to 16 counts) for about 30 minutes. This may also be baked as muffin in muffin tins.

ROLLS

278. Basic dough

10 pounds flour	13 ounces sugar
6½ ounces yeast, compressed	13 ounces fat (lard or lard substitute)
6 pints water or milk	2½ ounces salt

Dissolve the yeast in 2 pints of the water at a temperature of 80° F. Dissolve the sugar and salt in remainder of water. Add this to the flour and mix slightly. Add the dissolved yeast and the fat and mix thoroughly. Regulate the quantity of liquid to make a soft dough. Set to rise in a well-greased pan covered with a slightly damp cloth. In cold weather, or if the kitchen is cold, it is well to keep this cloth dampened with warm (not hot) water. If the temperature of the room is about 80°, it is sufficient to allow the dough to rise. Ferment and punch as for basic sweet dough. It is best to work up this dough while it is still on the young side. Do not allow it to overferment.

This dough makes rolls, etc., which are preferred by many to those made from the basic sweet dough. It may be made into a variety of rolls, as parkerhouse, sandwich buns, finger rolls, pan rolls, etc., or may be used to make a raisin bread. It may also be used to make plain bread which is superior for toast.

279. Cinnamon rolls

Use the basic dough and make up into cinnamon rolls as given in recipe 269.

280. Finger rolls

Use the basic dough. Scale into 2-ounce pieces, using the method shown in recipe 281 but cutting from 32-ounce pieces. Roll each piece about twice in a circular motion (do not form into a complete ball), then with the flat hand roll out into a cylinder or "snake" about 5 inches long. Endeavor to keep the ends square. It requires some experience to make neat finger rolls. Then place the rolls well apart on a well-greased bakepan, allow to proof (rise) until about double in size, and bake about 15 minutes in a medium oven (325°-400° F.—12 to 16 counts). These rolls are used for hot dogs and are good for lunches in the field, on the target range, etc.

281. Pan rolls

Use the basic dough scaled into 1½-ounce pieces. Scale off pieces of dough weighing 24 ounces and roll out into "snakes" about 2 inches in diameter. Double over and cut in half, repeat this with each half;

this gives four pieces. Cut each of these in half; this gives eight pieces. Cut each of these in half and the result is 16 pieces, each weighing $1\frac{1}{2}$ ounces. This method is quick and with a little experience will give weights nearly enough accurate for practical purposes. Round up each piece into a neat ball and put close together in a well-greased bakepan. Allow to proof (rise) until about double in size and bake for about 15 minutes in a medium oven (325° - 400° F.—12 to 16 counts). Serve hot.

282. Parkerhouse rolls

Use the basic dough. Scale into $1\frac{1}{2}$ -ounce pieces as given in recipe 281. Round into neat balls and allow to rest on the table, first sprinkling some dusting flour to prevent sticking to the table. By the time the last of the dough has been rounded, the first pieces will be ready for working into rolls. Place four of these pieces in a row. Use a small rolling pin (a piece cut from a household size broomstick is the proper size) and put a crease or dent in the middle of each piece. Then brush across the creases with melted butter or a mixture of melted butter and lard; then fold over, so that top fold is one-third shorter than bottom fold. Seal the two folds together by pressing the top lip, but do not apply enough pressure to knock down. Place in well-greased bakepans about 2 inches apart, let proof (rise) until about double in size, and bake in a medium oven (325° - 400° F.—12 to 16 counts). Serve hot with butter, jam, or jelly.

283. Raisin bread

Wash 4 pounds of raisins, dredge with flour, then add to the basic dough when mixing. Then handle as for soft bun bread.

284. Soft bun bread

Use the basic dough and make up into loaves. If no individual bread pans are on hand, scale into 35-ounce pieces, round, and let rest until loose (about 20 minutes). Form into loaves and place six of these in one black iron bakepan. Proof (rise) until just above edge of pan and bake about 30 minutes in a medium oven (325° - 400° F.—12 to 16 counts).

285. Sandwich buns

Use the basic dough. Scale into 2-ounce pieces as for finger rolls. Round each piece into a neat ball and place 2 inches apart in well-greased bakepans. Allow to rise about 15 minutes, then flatten, using the palm of the hand, or the bottom of a can, or a board, etc. Then

allow to rise until about double in size and bake about 15 minutes in a medium oven (325°-400° F.—12 to 16 counts).

SALADS AND DRESSINGS

286. Apple and celery salad

9 pounds apples	3 pints mayonnaise dressing
8 pounds celery	1 head lettuce

Clean the celery and keep in a damp cloth so that it will remain crisp. When ready for use cut into $\frac{1}{2}$ -inch pieces. Save the celery leaves for use in soup, etc. Peel and core the apples and just before adding them to the mixture cut them into pieces similar in size to the celery. Add the mayonnaise dressing and mix well. Serve individually on lettuce leaves or in vegetable dishes garnished with lettuce leaves.

287. Baked bean salad

16 pounds baked beans	1 pint mayonnaise
4 pounds onions, chopped fine	$\frac{1}{2}$ pint vinegar
4 pounds sweet pickles, chopped fine	1 head lettuce
2 ounces mustard, prepared	Salt and pepper to taste

Mix all ingredients thoroughly and season to taste with salt, pepper, mustard, and vinegar. Left-over baked beans from dinner may be used for salad. Serve individually on lettuce leaves or in vegetable dishes garnished with lettuce leaves.

288. Bean, stringless, salad

20 pounds beans, fresh, stringless,	2 pints mayonnaise
cooked and cold, or 3 cans beans	$\frac{1}{2}$ pint vinegar
(No. 10 cans)	1 head lettuce
2 ounces mustard, prepared	Salt and pepper to taste

To the cold beans add the mustard, salt, vinegar, and mayonnaise, and mix well. Serve individually on lettuce leaves or in vegetable dishes garnished with lettuce leaves.

289. Beet salad, pickled

17 pounds beets, fresh, or 2 cans cut	2 pints vinegar
beets (No. 10 cans)	1 pound sugar

If fresh beets are used, cook and peel them, then dice in $\frac{1}{4}$ -inch cubes; if canned beets are used no cooking is necessary. Place the beets in a salad bowl and cover with vinegar and sugar solution. Let stand for 1 hour to cool and place in vegetable dishes. Serve cold.

290. Cabbage salad

20 pounds cabbage	4 bunches parsley
2 pounds celery, diced	1 quart dressing or 1 pint vinegar

Trim, core, wash, clean, and quarter the cabbage and soak in salted water for 1 hour. Clean, trim, wash, and dice celery and soak in cold water until ready to use. Just before serving, remove cabbage from the water and shake. Shred or chop fine and place in a large bowl with the diced celery, then pour over it the dressing or vinegar. Mix well. Place in vegetable dishes and cover with minced parsley and serve cold.

291. Cabbage and apple salad

15 pounds cabbage	5 pounds apples
1 quart mayonnaise	

Prepare the cabbage as for cabbage salad. Wash, peel, and core the apples and place in cold water until just before serving. At that time remove and chop fine and shred the cabbage. Mix the cabbage, apples, and mayonnaise, and salt to taste. Serve individually on lettuce leaves or in vegetable dishes garnished with lettuce leaves.

292. Celery salad

15 pounds celery, trimmed	1 pint vinegar
15 eggs	1 pint water
4 pounds potatoes, mashed	2 ounces mustard, prepared
2 pounds bacon grease or cooking oil	5 heads lettuce

Dice the celery fine and let stand in cold water. Hard-boil the eggs, chop fine, and mix with the diced celery. Make a dressing as follows: Mash the potatoes; mix in slowly the bacon grease (or cooking oil) with the vinegar and water; then mix in the mustard and a little red pepper and salt to taste. The dressing should be of the consistency of cream or gravy. Regulate the quantity of water to get this result. Pour the dressing over the celery-and-egg mixture and serve cold on dishes garnished with lettuce leaves.

293. Chicken salad

30 pounds chicken (fowl)	2 quarts dressing
12 pounds celery, trimmed	5 heads lettuce

Prepare the chicken as for chicken stew. Simmer until so tender that the meat may be easily separated from the bones. Be careful to avoid leaving any bones with the meat. Dice the meat when cold, add the diced celery, and mix with the mayonnaise. Season to taste

with salt and pepper and garnish with a little paprika sprinkled over the top. Serve cold on lettuce leaves.

The above is sufficient for a main dish. To serve as a salad the quantity of ingredients may be cut in half.

If desired, veal may be substituted for one-half the chicken. If simmered with the chicken the veal will take on a chicken flavor.

294. Cucumber and onion salad

25 pounds cucumbers	1 quart vinegar
8 pounds onions, sliced	Salt and pepper to taste

Peel the cucumbers and slice thin, cover with salted cold water, and allow to stand for 2 hours. Drain, add the onions and vinegar, and season to taste with salt and pepper.

295. Lettuce salad

13 heads lettuce, medium size	1 quart vinegar
12 eggs, hard boiled, minced fine	2 ounces mustard, prepared
2 pounds bacon, diced and browned	

Wash and clean the lettuce thoroughly and cut into eights. Soak in cold water about 1 hour. Mix the bacon, mustard, minced eggs, vinegar, and a little pepper and salt, and pour over the lettuce when cold. Serve ice cold. Lettuce may also be cut into eights and served with thousand island dressing.

296. Piccalilli salad

5 pounds cabbage, minced	5 pounds onions, minced
5 quarts tomatoes, minced, or 4 cans tomatoes (No. 3 cans) or 1 can tomatoes (No. 10 can)	5 pounds pickles, sweet, minced
	1 quart vinegar
	1 teaspoonful cloves, ground

Mix all the ingredients well, season with salt, cayenne pepper, and cloves, and add sufficient water to make $3\frac{1}{2}$ gallons. Regulate the quantity of water to make the consistency like thick gravy.

297. Pimento salad

5 cans pimentos (1-pound cans)	5 heads lettuce
14 pounds cabbage	2 pounds pickles, sweet
2 pounds celery, diced	1 quart mayonnaise dressing

Prepare the cabbage as in cabbage salad. Select one-fourth of the pimentos best suited for the purpose and slice them into fine cords like shoestrings. Chop fine remaining pimentos and pickles. Re-

move the cabbage from the water, shake, shred, and mix with the chopped pimentos, diced celery, chopped pickles, and the mayonnaise. Serve cold on lettuce leaves.

298. Potato salad

25 pounds potatoes, boiled and diced	1 can pimentos, or 4 green peppers, diced
5 pounds celery, diced	½ pint vinegar
2 pounds onions, minced	1 quart mayonnaise
2 pounds bacon, diced and browned	1 head lettuce or parsley

Place the potatoes in a chopping bowl with the onions and celery over them. Fry the bacon until brown and while still hot pour over the potatoes. Add the vinegar, mayonnaise, and pimentos or peppers mixed together. Mix well and season with pepper and salt to taste. Allow to stand for 2 hours, then serve cold in dishes garnished with lettuce or parsley.

299. Raw vegetable salad

6 heads lettuce (medium size)	2 pounds celery, diced
1 pound carrots, sliced and chopped fine	4 pounds cabbage, grated
2 pounds green pepper, chopped fine	2 pounds tomatoes
4 bunches radishes, sliced	1 pint mayonnaise
2 pounds cucumbers, diced	½ pint vinegar

Chop fine three heads of lettuce, add rest of the ingredients, and salt and pepper to taste. Serve cold in dishes garnished with the three remaining heads of lettuce.

300. Salmon salad

12 cans salmon (1-pound cans)	1 gallon mayonnaise dressing
2 pounds celery, diced	3 green peppers
10 pounds potatoes, boiled and diced	6 lemons
3 heads lettuce	

Cool the cans of salmon and empty contents into a mixing bowl. Be sure to add all the oil in the can. Chop salmon fine and mix with the potatoes. Soak the diced celery in cold water for 1 hour, chop up the green peppers and add to the mixture. Add the mayonnaise and thoroughly mix. Garnish with sprigs of parsley or lettuce and serve cold on lettuce leaves with the lemons cut in thin slices and laid across the top of the salad.

301. Slaw (coleslaw)

20 pounds cabbage	1 quart vinegar
4 pounds bacon, diced and browned	2 pounds sugar
6 pounds onions, chopped fine	

Wash the cabbage thoroughly and shred or chop fine. Mix thoroughly the onions, bacon, vinegar, and sugar. Season to taste with pepper and salt and bring to a boil. Remove from the fire and pour over the chopped cabbage. Serve hot or cold.

302. Tomatoes, sliced

30 pounds tomatoes

Wash the tomatoes well and trim away discolored or bruised spots. Place in the refrigerator until thoroughly chilled, then slice thin or cut into eighths and replace in the refrigerator until required. Place sliced tomatoes on lettuce and serve plain or with dressing over both.

303. Vegetable salad

17 pounds vegetables, cooked, consisting of—

5 pounds carrots	2 pounds cucumbers, sliced, or celery,
5 pounds peas	diced, or radishes, diced
5 pounds string beans	

Nearly any kind of left-over cooked vegetables may be used in making salads by seasoning them with mustard, vinegar, or mayonnaise or french dressing. Serve ice cold on dishes garnished with lettuce leaves.

304. Boiled dressing

3 eggs	½ ounce mustard, dry
¼ pound butter	1 pound flour
¼ pound sugar	1 pint milk (approximately)
1 gallon water	Salt and cayenne pepper to taste
1 pint vinegar	

Put mustard, salt, sugar, and cayenne pepper into a kettle, pour over the vinegar, and heat to near boiling point. Rub the flour and butter together and add to the hot mixture. Beat the eggs, add the water, and let cook until like prepared mustard; add milk until right consistency.

This dressing may be used as a base, instead of mayonnaise, to make other dressings such as tartar sauce, thousand island, cucumber mayonnaise, etc.

305. French dressing.

½ teaspoonful paprika	6 teaspoonfuls sugar
6 teaspoonfuls salt	2½ pints cooking or salad oil
½ teaspoonful pepper, white	1 pint vinegar

Put the salt, pepper, paprika, sugar, and vinegar in a dish and beat thoroughly, then add slowly the oil, beating continuously. This dressing should not be poured over the salad until immediately before

serving. A lemon dressing may be made by substituting 1 pint juice of fresh lemons for the vinegar.

306. Mayonnaise dressing

6 eggs	2 tablespoonfuls mustard
1 gallon salad oil	Salt and cayenne pepper to taste
8 tablespoonfuls vinegar	

First, every utensil used should be chilled or cooled. Break open the eggs into a mixing bowl and add the cayenne pepper, salt, and mustard. Work it in until it is thoroughly mixed. Begin dropping in the oil, stirring constantly in the same direction, putting in only a few drops at first. When it begins to thicken, drop in a few drops of vinegar, then the oil again, a very little. Continue this until all of the materials are used. Be careful not to use too much vinegar as this makes it thin. It should be thick enough to drop when ready for use.

307. Mustard salad dressing

1 pound butter	1 $\frac{3}{4}$ gallons water
2 pounds flour	$\frac{1}{4}$ gallon vinegar
$\frac{1}{4}$ pound mustard, dry	

Melt the butter in a double boiler, stir in the flour and mustard, and cook until smooth. Reduce it with the vinegar and water to the desired thickness. Serve when cold.

308. Salad dressing, eggless

6 ounces sugar	$\frac{3}{4}$ pint vinegar
4 ounces salt	2 $\frac{1}{4}$ pints salad oil
1 ounce mustard, dry	3 pints water, cold
1 teaspoonful paprika	6 ounces cornstarch

Place the sugar, salt, mustard, paprika, vinegar, and salad oil in a mixing bowl but do not stir. Make a paste by mixing the cornstarch with half the water, then add the other half of the water. Cook the paste over a slow fire, stirring constantly until it boils and becomes clear. Then add the hot paste to the other ingredients in the mixing bowl and beat briskly with an egg beater or wire whip until smooth. Chill before serving.

309. Sour cream dressing

1 $\frac{1}{2}$ pints vinegar	3 teaspoonfuls salt
1 quart milk, fresh; or 1 can evaporated milk diluted with 1 pint water	$\frac{1}{4}$ teaspoonful pepper, cayenne
	6 tablespoonfuls sugar
$\frac{1}{2}$ pint salad oil, or 8 ounces melted butter	4 teaspoonfuls mustard, dry

Add the vinegar to the milk, then the oil, then all other ingredients, stirring briskly with a wire beater. Keep cold.

310. Tomato french dressing

2 cans soup, tomato (No. 1 cans)	$\frac{1}{2}$ ounce onion juice, or $\frac{1}{2}$ pound
$1\frac{1}{2}$ pints salad oil, or olive oil	onions, finely minced
$\frac{1}{2}$ pint vinegar	1 ounce salt
$\frac{1}{2}$ pound sugar	$\frac{1}{4}$ ounce mustard, dry
	$\frac{1}{8}$ ounce paprika

Mix the ingredients in the order given in an electric mixer or whip by hand. Serve cold.

311. Thousand island dressing

1 gallon mayonnaise dressing, or 1 pint pickles, chopped, or sweet relish	
boiled dressing	1 cup horseradish, grated (if avail-
1 quart tomato catsup or chili sauce	able)

Mix the above ingredients thoroughly. One-half pint chopped green olives improves the dressing.

BEVERAGES

312. Cocoa or chocolate

3 pounds cocoa, or $2\frac{1}{2}$ pounds chocolate, plain	5 pounds sugar
	32 cans milk, evaporated

Put 8 gallons of water into an urn or boiler and bring to a boil. Take out 1 gallon of the hot water and dissolve the cocoa and sugar in this. If chocolate is used, first melt it in a double boiler. Then add to the remainder of the hot water and cook 5 minutes. Reduce the heat and add the milk, and stir well. Water may be used in place of milk, but this reduces the palatability.

In hot weather, iced cocoa is popular.

313. Coffee, hot

$12\frac{1}{2}$ gallons water, cold	5 pounds coffee, roasted and ground
-------------------------------------	-------------------------------------

Bring the water to a boil. Move container to back of stove in order to reduce temperature of water slightly under the boiling point. Place roasted and ground coffee in sugar interliner bag, or other similar bag, and tie same with cord, leaving sufficient room in the bag to permit expansion of the coffee. Place the bag containing the coffee in water, when water is slightly under boiling point, and allow to simmer, not boil, for 10 to 12 minutes. Stir the bag occasionally during the simmering period. Remove the bag. Serve at once.

Observe the following rules to insure good coffee :

a. Keep roasted and ground coffee in a container as airtight as possible.

b. Carefully measure quantities of both water and coffee.

c. When grounds are removed from coffee, throw them away. Do not use these grounds to make additional quantities of coffee, and do not use part spent grounds and part unused grounds for subsequent brews. Always use fresh (unused) ground coffee.

d. Be sure to bring water to a boil, but do not add coffee to water until the water has cooled slightly below the boiling point.

e. Serve the coffee as soon as possible after completion of brew. The brew should not be completed more than 15 minutes prior to time of serving.

f. Scour the coffee boiler daily.

g. After removing grounds from muslin bag or sack, the sack should be washed in lukewarm, not hot, water, thoroughly rinsed in cold water, and then permitted to remain submerged in a pan of cold water until ready to use again.

314. Lemonade

13 gallons ice water
7 pounds sugar

100 lemons
10 pounds ice

Squeeze the juice from the lemons with a lemon squeezer and add it to the water. Sweeten to taste with sugar and stir thoroughly before serving. Serve cold.

315. Tea, hot and iced

Hot tea

7 gallons water, fresh
10½ ounces tea

Cold tea

1 gallon water
15 ounces tea
18 lemons, or left-over lemonade to taste
9 gallons water

Hot tea.—Bring the water to a boil and remove from the range. Suspend the tea from the top of the boiler in a muslin bag and allow to stand in the hot water for 5 minutes. The bag should be sufficiently large to give the tea plenty of room so that the boiling water will penetrate all portions of it. Remove the bag of tea, stir the beverage, and serve hot.

Iced tea.—Use 1 gallon of water and 15 ounces of tea and prepare as for hot tea. Cool and just before serving add sufficient cold water to make 10 gallons. The juice of 18 lemons may be added, if desired. Any left-over lemonade may be added to the iced tea.

APPENDIX

TABLES AND USEFUL INFORMATION

	Paragraph
Standards of measure.....	1
Utensils available for measuring.....	2
Weights and measurements of fruits and vegetables.....	3
Weights, measurements, and equivalents of other foods.....	4
How to measure.....	5
Egg conversion table.....	6
Milk conversion table.....	7
Boiling point of water under various pressures.....	8
Table of oven temperatures as determined by hand-second counts.....	9
Oven counts and temperatures.....	10
Meat cookery tables.....	11
Care and use of deep-fat fryers.....	12
Soap, making.....	13
Window washing.....	14
Separation and disposal of kitchen waste and garbage.....	15

1. Standards of measure.—*a. Avoirdupois weight.*

16 ounces equal 1 pound.

100 pounds equal 1 hundredweight.

20 hundredweight equal 1 ton.

b. Dry measure.

2 pints equal 1 quart.

8 quarts equal 1 peck.

4 pecks equal 1 bushel.

c. Liquid measure.

4 gills equal 1 pint (16 fluid ounces).

2 pints equal 1 quart (32 fluid ounces).

4 quarts equal 1 gallon.

31½ gallons equal 1 barrel.

2 barrels equal 1 hogshead.

2. Utensils available for measuring.—Scales and standard liquid measures are frequently issued to messes in barracks, but are not issued in the field. However, in their absence the cook can use dippers, mess kit cups, and mess kit spoons for measuring the quantities called for in recipes.

a. The mess kit spoon (M1926) is used for small measurements.

b. The quartermaster tablespoon is slightly larger than the M1910 spoon, but for practical purposes it may be used as identical measure.

c. Mess kit cup (1910), holds 1½ liquid pints.

d. Dipper No. 56 holds 1 liquid quart.

e. Dipper No. 55 holds 1¾ liquid quarts.

3. Weights and measurements of fruits and vegetables.

Item	Weight (pounds)	Measurement
Apples	48	1 bushel.
Apples	1	2½-No. 3 each (medium).
Apples, sliced	1½	1 No. 56 dipper (1 quart).
Bananas	1	3 each (medium).
Beans, fresh lima	32	1 bushel.
Beans, fresh snap	30	1 bushel.
Beets	52	1 bushel.
Beets	1	3-4 each (medium).
Cabbage	40-50	1 bushel.
Cabbage	2½-3	1 head.
Carrots	50	1 bushel.
Carrots	1	3-6 each (medium).
Cauliflower, stripped, raw	1-3	1 head.
Cucumbers	48	1 bushel.
Eggplant	33	1 bushel.
Eggplant, 1 medium, sliced	1	9 slices.
Grapes	50	1 bushel.
Lettuce	18-19	1 bushel.
Onions, dry	50	1 bushel.
Onions, dry	1	4-5 each (medium).
Parsley	30	1 bushel.
Parsnips	45-50	1 bushel.
Peaches, fresh	48	1 bushel.
Peaches, fresh	1	3-5 each (medium).
Pears, fresh	52	1 bushel.
Pears, fresh	1	3-4 each (medium).
Peas, fresh, in pods	30	1 bushel.
Peppers, fresh green	25	1 bushel (125).
Peppers, fresh green	1	5-7 each (medium).
Pineapple, fresh	2	1 each (medium).
Potatoes, irish	60	1 bushel.
Potatoes, irish	1	2-4 each (medium).
Potatoes, sweet	50-54	1 bushel.
Potatoes, sweet	1	3-4 each (medium).
Radishes	1	80-90 each (medium).
Radishes		6-12 per bunch.
Rhubarb, raw, diced	1	1 No. 56 dipper (1 quart).
Rutabagas	56	1 bushel.
Spinach	18	1 bushel.
Squash	45	1 bushel.
Tomatoes, fresh	50-60	1 bushel.
Tomatoes, fresh	1	4 each (medium).
Turnips	52	1 bushel.
Turnips	1	2-3 each (medium).

NOTE.—One 3-gallon bucket of potatoes weighs 17 pounds, and when peeled will weigh about 15 pounds. One 3-gallon bucket of onions weighs about 14 pounds, and when peeled will weigh about 11 pounds.

THE ARMY COOK

4. Weights, measurements, and equivalents of other foods.—
All measurements are level.

Food	M1910 spoon	Mess kit cup 1½ pints)		No. 56 dipper (1 quart)		No. 55 dipper (1¾ quarts)	
	Ounces	Pounds	Ounces	Pounds	Ounces	Pounds	Ounces
Allspice, ground	½						
Apples, evaporated			7		9	1	
Apricots, evaporated		1		1	5	2	5
Baking powder	⅜	1		1	6	2	7
Baking soda	½	1	4	1	11	3	
Barley		1	8	2		3	8
Beans, dry:							
Kidney		1	3	1	9	2	12
Lima		1	4	1	10	2	14
Navy		1	5	1	12	3	
Beef, ground, raw		1	8	2		3	8
Bread, crumbs, dried			8		11	1	3
Butter		1	8	2		3	8
Celery, cubed			12	1		1	12
Cheese:							
American cheddar, grated or ground			12	1		1	12
Cottage		1	8	2		3	8
Chili powder	¼						
Cinnamon, ground	¼						
Cloves, ground	⅓						
Cocoa	¼		11		14	1	8
Coconut, shredded			7		9	1	
Coffee			10		13½	1	8
Corn meal, yellow		1		1	5	2	4
Cornstarch	⅓		15	1	4	2	3
Cream of tartar	⅓						
Curry powder	⅓						
Eggs:							
Dried	¼		9		12	1	5
Whole without shell		1	8	2		3	8
White		1	8	2		3	8
Yolk		1	8	2		3	8
Flour, issue:							
Sifted	¼		12	1		1	12
Unsifted	¼		12¾		16½	1	12½
Gelatin	¼		12	1		1	12
Ginger, ground	⅓						
Lard substitute		1	8	2		3	8
Lentils			14	1	3	2	2
Mace	⅓						
Milk, powdered	¼		12	1		1	12
Mustard, dried	⅓						
Nutmeg, ground	¼						

Food	M 1910 spoon	Mess kit cup (1½ pints)		No. 56 dipper (1 quart)		No. 55 dipper (1¾ quarts)	
	Ounces	Pounds	Ounces	Pounds	Ounces	Pounds	Ounces
Oats, rolled.....			9		12	1	5
Onions, diced.....			11		15	1	10
Paprika.....	⅓						
Parsley, chopped.....			9		12	1	5
Peaches, evaporated.....			14	1	2	2	
Peas, split.....		1	5	1	12	3	1
Pepper, black.....	¼						
Peppers, green, chopped.....			12	1		1	12
Prunes, evaporated.....			14	1	2	2	
Poultry seasoning.....	⅛						
Raisins, seedless.....		1		1	4	2	5
Rice.....		1	8	2		3	8
Sage.....	⅛						
Salt, issue.....	⅝	1	13	2	6	4	4
Sugar:							
Brown (loose pack).....	¼		14	1	2	2	
Confectioners.....	¼		14	1	2	2	
Granulated.....	½	1	5	1	12	3	
Tapioca:							
Granulated.....		1	3	1	10	2	11
Pearl.....		1	2	1	8	2	10
Tea.....			7½		10	1	2
Vanilla.....	½						

5. **How to measure.**—All measurements are level. Draw a knife across the top of the measure when filled, so that the surface is level.

a. *Mess kit cup or dipper.*—To measure dry ingredients such as granulated sugar and flour, fill cup or dipper to desired level, and do not pack or shake. Flour should always be sifted once before measuring. When shortening, such as butter or other fats is measured, it should be soft enough to pack, if cup or dipper is to be completely filled. In measuring a lumpy product, break up lumps before measuring.

b. *Tablespoon.*—To measure dry ingredients or shortening by tablespoon, fill to overflowing and level with straight edge of knife. To divide in half, fill and level, and divide lengthwise with a knife. For quarters, cut another line directly across the center of the first one.

THE ARMY COOK

6. Egg conversion table.

	Fresh eggs	Powdered whole egg		Added water		
		Measure	Weight (ounces)	Measure	Weight (ounces)	
Standard measuring cup (8 fluid ounces).	1	2 tablespoon-fuls.	½	2 tablespoon-fuls.	1	
		¾ cup-----	2¼	⅔ cup-----	7	
		1½ cups-----	4¼	1¾ cups-----	14	
Army mess kit cup (24 fluid ounces).	12	½ cup-----	4½	½ cup-----	14	
		1 cup-----	9	1½ cups-----	28	
		36	1½ cups-----	13½	1¾ cups-----	40

7. Milk conversion table.—Conversion of milk in forms other than liquid milk to approximate equivalent in liquid whole milk.

Liquid whole milk (pounds)	Evaporated milk		Dry whole milk				Dry skim milk								
	Milk (14½-ounce cans)	Water		Milk (whole dry)		Water		Milk (dry skim)		Butter or shortening		Water			
		Pounds	Ounces	Pounds	Ounces	Pounds	Ounces	Pounds	Ounces	Pounds	Ounces	Pounds	Ounces		
2.1 (1 quart)-----	1	1	-----	4	1	12	-----	3	-----	1	1	14			
8.6 (1 gallon)-----	4½	4	-----	1	4	-----	12	-----	4	7	6				
5-----	2½	2½	-----	10	4	6	-----	7	-----	3	4	6			
10-----	5½	5	-----	1	3	8	13	-----	14	-----	6	8	12		
20-----	11	10	-----	2	6	17	10	-----	1	12	-----	11	17	9	
30-----	16½	15	-----	3	9	25	7	-----	2	10	-----	1	26	6	
40-----	22	20	-----	4	12	35	4	-----	3	8	-----	1	35	2	
50-----	27½	25	-----	5	15	43	1	-----	4	6	-----	1	43	14	
60-----	33	30	-----	7	2	51	14	-----	5	5	-----	2	1	52	10
70-----	38½	35	-----	8	5	60	11	-----	6	3	-----	2	6	61	7
80-----	44	40	-----	9	12	70	4	-----	7	1	-----	2	12	70	3
90-----	49½	45	-----	10	14	79	2	-----	8	-----	-----	3	2	78	14
100-----	55	50	-----	12	-----	88	-----	-----	9	-----	-----	3	8	87	8

8. Boiling point of water under various pressures.—The following table shows approximate temperatures possible to attain with pressure cookers:

Pounds of pressure	Temperature
1.5-----	217° F.
3.5-----	222° F.
5-----	230° F.

<i>Pounds of pressure</i>	<i>Temperature</i>
10-----	240° F.
15-----	250° F.

NOTE.—Since temperatures attained with use of pressure cooker are high, as indicated above, the cooking time is proportionately shortened.

9. Table of oven temperatures as determined by hand-second counts.

	First counts for searing	Counts for cooking after searing	Time
Meats:			
Beef roast, 5-pound pieces.....	10	18	20 minutes per pound.
Mutton roast, 5-pound pieces..	12	20	20 minutes per pound.
Pork roast, 5-pound pieces.....	15	20	30 minutes per pound.
Veal roast, 5-pound pieces.....	12	18	30 minutes per pound.
		Counts	Time
Fowl:			
Turkey roast, 12 pounds each.....		18	20 minutes per pound.
Chicken roast, 3 pounds each.....		18	30 minutes per pound.
Duck roast, 3 pounds each.....		18	30 minutes per pound.
Salmon hash.....		16	15 minutes per pound.
Vegetables:			
Beans, dry.....		22	6 to 8 hours.
Carrots, according to size.....		16	20 minutes.
Parsnips, according to size.....		18	40 to 60 minutes.
Potatoes, baked, according to size.....		12	30 to 40 minutes.
Potatoes, browned.....		15	20 to 30 minutes.
Potatoes, cheesed.....		12	30 minutes.
Potatoes, hashed.....		12	30 minutes.
Potatoes, lyonnaise.....		12	15 to 30 minutes.
Potatoes, sweet, according to size.....		16	40 to 60 minutes.
Squash, according to size.....		18	30 to 40 minutes.
Breads:			
Braided bread, 2-ounce.....		14	20 to 25 minutes.
Cinnamon rolls, 2-ounce.....		12	10 to 15 minutes.
Jenny Linds, 16-ounce.....		20	30 to 40 minutes.
Muffins, 2-ounce.....		15	20 to 30 minutes.
Parkerhouse rolls, 2-ounce.....		12	10 to 15 minutes.
Raisin buns, 2-ounce.....		18	35 to 40 minutes.
Sandwich buns, 2-ounce.....		12	10 to 15 minutes.
Tea buns, 2-ounce.....		18	35 to 40 minutes.
French bread, 18-ounce (13 inches long).....		20	40 minutes.
Cakes:			
Apple, 16-ounce (6 by 10 inches).....		15	20 to 30 minutes.
Coffee, 16-ounces (6 by 10 inches).....		15	15 to 20 minutes.
Pies.....		12	30 to 40 minutes.
Pudding, bread.....		15	30 to 40 minutes.
Custard.....		16	20 to 30 minutes.

THE ARMY COOK

10. Oven counts and temperatures.

Counts	Degrees Fahrenheit	Common name for oven temperature
8.....	450 to 500.....	Hot.
9 to 12.....	400 to 450.....	Quick.
12 to 16.....	325 to 400.....	Medium.
16 to 18.....	250 to 325.....	Moderate.
18 to 20.....	200 to 250.....	Slow.

NOTE.—It must be remembered that an oven count will vary according to the individual and also vary as the hand of the person making the count is sensitive or insensitive to heat. This is affected by the occupation of the man making the count. Cooks and others accustomed to working in heat are able to keep their hands in a hot oven longer than persons not accustomed to heat. Therefore, the only absolutely accurate method of determining oven temperature is by a thermometer. However, if no thermometer is available, the hand-second method will give fairly satisfactory results.

11. Meat cookery tables.—*a. Braising.*—(1) *Cuts for braising.*—All meat cuts can be used for braising but the following are recommended for this method of cooking:

(a) Beef.

Round, outside (bottom round).

Rump, boneless.

Chuck:

Clod.

Chuck roll.

Boneless neck.

Chuck tender.

Plate, boneless.

Brisket, boneless.

(b) Variety meats.

Liver.

Heart.

Kidney.

(c) Veal.

Boneless shoulders.

Boneless breasts.

Shank meat.

Neck meat.

Boneless flanks.

(d) Lamb.

Boneless shoulders.

Boneless breasts.

Shank meat.

Neck meat.

- (e) *Pork (fresh).*
 - Loin chops.
 - Leg steaks.
 - Shoulder steaks.
 - Spareribs.
 - Pork hocks.

(2) *How to braise.*—(a) Season with salt and pepper. Herbs, spices, and vegetables may be added for flavor variety.

(b) Brown meat on all sides in hot fat. Browning develops aroma, flavor, and color.

(c) Add a very small amount of liquid, if necessary. Both meat and gravy will be more attractive. No liquid should be added to pork chops.

(d) Cook at a simmering temperature (185°-200° F.). Meat should never be boiled. High temperature dissolves connective tissue, making meat stringy and hard to carve. It also increases shrinkage and dries out meat. Braising may be done in oven or on top of range.

(3) *Timetable for braising.*

Meat cut	Average weight or thickness	Approximate cooking time (hours)
Beef:		
Pot roast.....	3 to 5 pounds.....	3 to 4.
Swiss steak.....	1½ to 2 inches.....	2 to 3.
Round steak.....	¾ inch.....	¾.
Birds.....	½ inch.....	1½.
Shortribs.....	2 inches.....	1½.
Fricassee.....	2-inch cube.....	1½.
Veal:		
Breast:		
Stuffed.....	4 pounds.....	2.
Rolled.....	3 pounds.....	2.
Birds.....	½ inch.....	1.
Chops.....	½ to ¾ inch.....	1.
Chops (breaded).....	do.....	¾ to 1.
Steaks.....	do.....	¾ to 1.
Lamb:		
Breast:		
Stuffed.....	2 to 3 pounds.....	1½ to 2.
Rolled.....	1½ to 2 pounds.....	1½ to 2.
Neck slices.....	¾ inch.....	1.
Shanks.....	½ pound each.....	1½ to 2.
Pork:		
Chops.....	¾ to 1 inch.....	¾ to 1.
Shoulder steaks.....	¾ inch.....	½ to ¾.
Spareribs.....	2 to 3 pounds.....	1½.

THE ARMY COOK

b. Frying and deep-fat frying.—(1) *Frying.*—Frying means to cook in a shallow layer of fat. It differs from pan-broiling in which no fat is added, and is used for thin slices of round steak, veal steak and chops, liver, and sometimes pork chops. Frying gives crispy browned exterior and fine-flavored but less tender product than braising.

(2) *Method for frying.*—Dredge meat in flour, if desired. Season with salt and pepper. Brown quickly on both sides in a small amount of hot fat. Do not cover. Continue to cook at reduced temperature until done.

(3) *Deep-fat frying.*—Deep-fat frying means to cook in a deep layer of fat. It is not recommended for uncooked meat. It may be a convenient method for browning breaded chops which have been partially or wholly cooked before crumbing, and is often used to finish cooking precooked chicken. It is used in preparation of croquettes. Care should be taken to keep fat from smoking.

(4) *Temperatures for deep-fat frying.*

Food	Temperature (°F.)	Bread test (seconds)	Cooking time
Croquettes.....	375	60	To golden brown.
Doughnuts.....	350	40	2 minutes each side.
French-fried onions.....	360	50	To golden brown.
French-fried liver.....	350	60	Until brown.
Fritters.....	360	50	3 to 5 minutes.
French-fried potatoes.....	370	60	5 to 12 minutes.
Shoestring potatoes.....	370	60	3 to 5 minutes.
Potato chips.....	370	60	2 minutes.

c. Pan broiling.—(1) *Cuts for pan broiling.*

(a) *Beef (steaks).*

Round:

Top round (inside).

Sirloin tip (knuckle).

Loin:

Filet mignon (tenderloin).

Top sirloin (sirloin butt).

Strip club (strip).

Rib (Spencer roll).

Chuck, inside (chuck roll).

(b) *Variety meats.*

Liver.

(c) *Veal.*—Veal is never pan broiled.

(d) Lamb.

Leg steaks.

Loin chops.

Rib chops.

Shoulder chops.

*(e) Pork (fresh).—*Fresh pork should not be pan broiled.*(f) Pork (smoked).*

Ham.

Bacon.

(2) How to pan broil.—(a) Place meat on heavy frying pan or griddle. Pan need not be preheated.*(b)* Do not add fat. Enough fat cooks out to grease pan.*(c)* Brown well on both sides. This develops flavor and aroma.*(d)* Season with salt and pepper.*(e)* Reduce temperature; meat will be juicier. Prevents over-browning.*(f)* Do not cover or add water. The meat will braise, not broil, in the presence of moisture. The aim in pan broiling is to get results comparable to broiling.*(g)* Turn occasionally. This insures even cooking.*(h)* Pour off fat which collects in pan. Meat should broil, not fry.*(3) Cooking time.—(a)* Definite times for pan broiling cannot be given. The time is about the same as for broiling a cut of same thickness.*(b)* To test for sufficient cooking cut small gash and note color.*(c)* Beef steaks may be cooked rare to medium. Ground meat should be cooked well done.*(4) Suggestions.—(a)* Use tender cuts.*(b)* Steaks or chops should not be cut too thick.*(c)* When pan broiling ground meat, rub pan with a little fat.*d. Roasting.—(1) Cuts that may be used for roasting.**(a) Beef.*

Round:

Inside (top round).

Knuckle (sirloin tip).

Loin:

Tenderloin.

Sirloin butt.

Strip.

Rib (spencer roll).

Chuck roll.

THE ARMY COOK

- (b) *Veal.*
 Boneless legs.
 Boneless loin.
 Boneless rack.
 Boneless shoulders.
- (c) *Lamb.*
 Boneless legs.
 Boneless loin.
 Boneless rack.
 Boneless shoulders.
- (d) *Pork (fresh).*
 Boneless leg rolls.
 Boneless loin rolls.
 Boston butt.
 Fresh picnic shoulder.
 Spareribs.
- (e) *Pork (smoked).*
 Ham.
 Picnic.
 Shoulder butt.

(2) *How to roast.*—(a) Wipe with a clean, damp cloth. Meat should never be washed.

(b) Season with salt and pepper. Seasoning may be added at start, during, or end of cooking.

(c) Place fat side up. Basting is not necessary—as fat melts it runs over and through meat.

(d) Do not cover. Steam surrounds meat which is covered, making it a pot roast.

(e) Roast at a constant, moderate temperature (325° F.—16 counts). Searing does not keep in juices. Meat and gravy will be nicely browned without initial sear. A moderate temperature reduces shrinkage and increases flavor, juiciness, and tenderness.

(f) Do not add water. With a moderate temperature, drippings will not burn.

(g) Roast until done. Time depends on kind of meat, degree of doneness, and oven temperature. A meat thermometer is the most accurate way to tell when roast is done.

(3) *Timetable for roasting meats at 325° F.*

Kind of meat	Minutes per pound
Beef:	
Rare.....	18 to 20.
Medium.....	22 to 25.
Well done.....	27 to 30.
Rolled roasts.....	10 to 15.
Veal.....	25 to 30.
Lamb.....	30 to 35.
Rolled roasts.....	10 to 15 extra.
Pork.....	30 to 35. (Always cook pork very well done with no trace of pink.)
Smoked pork:	
Large ham.....	20.
Small ham.....	25.
Picnic.....	35.

e. Stewing.—(1) *Cuts for stews.*—All meat cuts can be used for stewing but the following are recommended for this method of cooking:

- (a) *Beef.*
 - Flank meat.
 - Shank meat.
 - Hanging tenderloins.
 - Boneless neck.
 - Boneless brisket.
 - Boneless plate.
- (b) *Variety meats.*
 - Heart.
 - Kidney.
- (c) *Veal.*
 - Boneless shoulders.
 - Boneless breasts.
 - Boneless flanks.
 - Neck meat.
 - Shank meat.
- (d) *Lamb.*
 - Boneless shoulders.
 - Boneless breasts.
 - Shank meat.
 - Neck meat.

THE ARMY COOK

(2) *How to make stew.*—(a) Have meat cut in small cubes. A boneless stew is more attractive than one with bones. Avoid bone splinters by avoiding use of cleaver, if stew meat is not boneless.

(b) Season with salt and pepper. The salt will penetrate small pieces, so is best put in at start of cooking.

(c) If desired, brown on all sides in hot fat. A browned stew has more meat flavor than a light stew.

(d) Cover with water. The water need not be boiling as hot water does not seal in juices any more than searing. Meat should be covered by water so that all will be cooked at same temperature.

(e) Cover kettle.

(f) Cook at a simmering temperature (185°–200° F.) until tender (about 2 to 2½ hours). Meat will be stringy and tasteless if boiled.

(g) Add vegetables just long enough before meat is tender so that they will be done, but not overcooked. Vegetables should be uniform in size.

(3) *For variety in stews.*—(a) Use different combinations of vegetables.

(b) Strive for attractive color combinations.

(c) Tomatoes will give flavor variety to the gravy.

(d) Omit potatoes and serve rice or boiled noodles in their place.

(e) Turnips give a sweet taste to a stew which many do not relish.

(f) Avoid the use of parsnips or other vegetables which many do not like.

f. Cooking in water (large cuts).—(1) *Cuts for cooking in water.*

(a) *Beef.*

Flank meat.

Shank.

Neck.

Brisket.

Plate.

Corned beef.

(b) *Variety meats.*

Heart.

Tongue.

(c) *Pork (fresh).*

Spareribs.

Pig's feet.

Pork hocks.

(d) *Pork (smoked).*

Ham.

Picnic.

Shoulder butt.

(e) *Veal.*—Veal is not cooked in water.

(f) *Lamb.*—Lamb is not cooked in water.

(2) *How to cook in water.*—(a) Cover meat with water. The water need not be hot since boiling water does not seal in juices. The meat should be entirely covered so that all of meat will cook at same temperature.

(b) Season with salt and pepper, except smoked pork cuts and corned beef. Cloves, peppercorns, bayleaf, or flavor vegetables may be added.

(c) Cover and cook at simmering temperature until meat is tender. Never boil because the connective tissue will be dissolved and the meat hard to carve; also, shrinkage will be greater and meat will be dry and tasteless.

(d) If vegetables, such as potatoes, onions, or cabbage, are cooked in kettle with meat they should be put in just long enough before meat is done for them to be tender. Overcooking vegetables gives them a poor texture and strong flavor.

(3) *Timetable for cooking in water.*

Cut	Average weight (pounds)	Approximate time per pound (minutes)
Ham:		
Large	12 to 14	20.
Small	10 to 12	25.
Half	6 to 8	30.
Picnic shoulder	4 to 8	45.
Corned beef	4 to 6	40 to 50.
Fresh beef	4 to 6	40 to 50.

g. Ground meat and its uses.—(1) *Cuts for grinding.*—Grinding breaks up the connective tissue and makes the meat tender. Any meat cut may be ground, but it is sound economy to use the least tender portions for grinding. The cuts given below are recommended.

(a) *Beef.*

Neck.

Shank.

Flank.

THE ARMY COOK

- Plate.
Brisket.
- (b) *Veal.*
Neck.
Shank.
Breast.
Flank.
Shoulder.
- (c) *Lamb.*
Neck.
Shank.
Breast.
Shoulder.
- (d) *Pork.*
Boston butt.
Picnic shoulder.
Lean trimmings.
- (e) *Smoked pork.*
Picnic.
Shoulder butt.
Ham trimmings.
- (f) *Variety meats.*
Liver.
Kidney.
Heart.

(2) *Suggestions for using ground meat.*—(a) *Loaf.*—Meat loaf is roasted like any tender cut in a moderate oven (350° F.). A loaf weighing 2¾ pounds will take 1½ to 2 hours.

1. The loaf may be made from one kind of meat or of two or more kinds. Good combinations are—
 - 1 part fresh pork to 3 parts lean beef.
 - 1 part smoked ham to 3 parts veal.
 - 1 part salt pork to 10 parts veal.
 - 1 part fresh lean pork to 2 parts smoked ham.
2. Liver may be used for loaf. The slices should be dropped in boiling water for a few minutes before grinding.
3. Ground lamb makes a good loaf, alone or with beef, pork, or veal.
4. Meat should be ground medium fine; too fine a grind makes the loaf too compact; if too coarse, the connective tissue is easily detected.

5. Seasoned meat may be shaped into a loaf and roasted or may be extended by the use of bread crumbs, mashed potatoes, or cereals.
6. If bread crumbs are dry, they should be moistened with water, milk, or tomato juice.
7. If the proportion of "extenders" is higher, a thick white sauce or eggs should be added as a binder.

(b) *Patties*.—Ground meat, with or without an "extender" may be shaped into patties usually about 1 inch thick. These are cooked by pan broiling or frying.

Salisbury steak is ground beef, seasoned only with salt and pepper and pan broiled on a lightly greased griddle.

(c) *Variety*.

1. Individual patties may be wrapped in bacon.
2. Variety in flavor may be obtained by the use of different seasonings: catsup, chili sauce, minced onion, mustard, or horseradish.
3. Uncooked liver ground with cooked meat for hash gives freshness.

12. *Care and use of deep-fat fryers*.—The *fryers* which have been installed in some mess kitchens are constructed on a scientific principle which practically assures good products. Heat is applied above the bottom of the cooking vessel. This results in having hot fat above and cold fat below. All sediment and particles drop into the cold fat, thus preventing burning which would help to "break down" fat. The thermostat should keep the fat at a constant temperature. (Do not overload the fryer because this results in lowering the temperature too much.)

a. *Before using fryer*.—Fill kettle with cleaning solution such as is used in dishwashers. Set the thermostat to 250° F. Boil for 10 minutes. Rinse with clean hot water and dry thoroughly.

b. *How much fat to use*.—Fill with fat to a level just enough to cover food being fried. Heat slowly so that fat will not be scorched. Fat which is held at smoking point will become scorched.

c. *Directions for frying*.—When fat has reached the temperature indicated for the recipe being used, put food in the basket and lower into fat. When browned, lift up basket, allow food to drain to remove free melted fat, and then turn food onto brown wrapping or other paper which will absorb excess fat.

d. *Fried foods in menus*.—Fried foods are desirable only when they are well cooked. Greasy, overcooked products are unappetizing and

THE ARMY COOK

slow to digest. Foods fried in deep fat should be a good color, crisp, and palatable. Use temperatures and times given in the table below.

Other foods which may be french fried are onions, french toast, croutons, boiled sliced sweet potatoes, eggplant, cucumbers, and squash which have been sliced and dipped in batter.

e. How to clean fryer.—(1) The fat should be drained off into kettle, strained through cheesecloth, or put to one side and allowed to settle.

(2) Fill the frying pot with water, heat to boiling, and add from 3 ounces to 1 pound of good cleaning compound (depending on size of fryer).

(3) After boiling for about 25 minutes, shut the burner off and allow to stand overnight, if possible.

(4) Drain and refill with water. Boil and drain.

(5) Refill with water, heat, and add from 2 tablespoonfuls to a cup of vinegar, depending on the size of the fryer. Stir and allow to stand a few minutes before draining. Refill with water and drain.

f. Reuse of fat.—Put strained fat in kettle and add fresh fat to proper level. There should always be enough fat to allow the temperature to remain reasonably constant.

Good care and intelligent use of a fryer insure its longer life and better fried products.

g. Table of time and temperatures for frying.

	Temperature (° F.)	Time (minutes)
Saratoga chips	325	5 to 8.
French fried, blanching	365 to 370	5 to 12.
French fried, browning	395 to 400	2.
Shoestring or julienne potatoes	325 to 350	3 to 10.
Latticed potatoes	350 to 375	3 to 10.
Perch and smelts	370	3 to 5.
Fish fillets	370	4 to 6.
Fish cakes, croquettes, etc	390	1.
Oysters, dredged	390	1.
Chicken, in batter	375	5 to 8.
Cutlets and breaded chops	360 to 400	5 to 8.
Doughnuts	385 to 390	3 to 5.
Fritters	370 to 380	2 to 5.

13. Soap, making.—*a. Boiled hard soap.*—Dissolve 1 pound of soda lye (sodium hydroxide, ordinary issue lye) in 2 quarts of water. In another container (5-gallon capacity) melt 5 pounds of clean fat

or tallow, scrap or drippings, in 2 gallons of water. As soon as all the fat is melted add about $\frac{1}{4}$ pint of the dissolved lye. Boil over a slow fire. Taste from time to time until the biting taste of the soap liquid has disappeared. Add water to replace that boiled away. Add another $\frac{1}{4}$ pint of lye as before and continue boiling, tasting, and adding lye and water in the same manner until the lye is consumed. The liquid will then become like honey in consistency and will be transparent as it drops from a spoon. Add about $\frac{1}{2}$ pound of salt. Boil until the soap separates from the lye water, has lost its honey-like appearance, and drops off a spoon or wooden paddle like greasy water. A small quantity pressed between the thumb and first finger will not feel greasy but will flatten into thin scales if the soap is finished. Simmer about 10 minutes and the process is complete. Skim off the soap which floats on the surface, place in a suitable mold or molds, and set aside to harden.

b. Soft soap.—Use 1 quart of the soap made according to the above formula but not hardened. Boil in a large kettle with 4 gallons of water until clear and uniform in appearance. Set aside to cool.

c. Inspection of soap.—(1) Cut a piece of soap in two and place the tongue on the fresh surface.

(a) If the soap is very sharp to the taste, not enough grease has been used.

(b) If the soap feels very greasy, too much grease has been used.

(c) If the soap tastes sharp and also feels greasy, it has not been mixed or boiled properly.

(2) A soap that is sharp to the taste and makes a good lather is much preferred for scrubbing purposes.

d. If the hard soap in process of setting is slightly soft and it appears that it will not harden, this difficulty may be overcome by attaching a short piece of rubber hose to the spout of an ordinary teakettle and placing the other end of the hose in the bottom of the soap kettle, thus introducing steam. In this way heat is obtained by using wet steam instead of the heat being applied to the bottom of the kettle. Available steam may also be drawn from boilers in lieu of the kettle method. A drier mixture and a harder soap result.

14. Window washing.—For efficient and economical window washing, to $1\frac{1}{2}$ gallons of water add 1 tablespoonful of kerosene. Dampen a soft cloth in this mixture and use for cleaning. Then rub with a dry cloth which polishes as well as dries the window. When the drying cloth becomes old and worn it may be used as a washing cloth and replaced by a fresh one. When long, high windows are involved, and it is impracticable to wash by hand, the cloth may

be attached to a handle with a cross bar at the end, similar to a squeegee. (The squeegee is simply a handle and a cross bar at the end, into which has been pressed a strip of hard rubber.) The use of the squeegee is not recommended, as it does not dry the windows thoroughly and requires the use of a drying cloth afterward. The above quantity of water and kerosene is usually sufficient for a day's work, but when the windows are very dirty or greasy a larger quantity is necessary.

15. Separation and disposal of kitchen waste and garbage.—

a. Proper garbage separation and disposal is necessary from a sanitary standpoint and also where it is to be used later for animal food. All kitchen waste and garbage not to be used by the organization should be separated into—

(1) That which is suitable for animal food, as bread, meat scraps, and vegetables.

(2) That which is not suitable for animal food, as coffee grounds, eggshells, fruit rinds or skins, and also glass and tin containers, waste paper, and ashes.

b. Containers used for garbage accumulation should have tight-fitting covers and be leakproof. There are various kinds of housings for garbage cans. They and the vicinity around them should be kept clean.

INDEX

	Paragraphs	Pages
Appliances, kitchen, directions for use.....	73	108
Baking.....	64	98
Beverages.....	35, 39, 65	70, 75, 100
Cooking:		
Assembling ingredients and utensils.....	72	108
Baking.....	64	98
Beverages.....	65	100
Carving and serving meats.....	57	90
Definition.....	4	3
Fish.....	59	91
Gravy.....	62	97
Heat, use.....	53	83
Importance.....	2	2
In fat.....	54	85
Meat, methods.....	56	88
Methods and terms defined.....	52	81
Plan of work.....	71	107
Poultry.....	58	91
Purpose.....	3	3
Salads.....	63	97
Seasoning of foods.....	55	87
Soups.....	61	95
Vegetables.....	60	92
Dairy products.....	35	70
Eggs.....	36	72
Field cooking.....	76	114
Army field ranges:		
Installing and handling.....	77	114
M1937.....	78	126
Installation and use on troop trains.....	80	140
No. 1, installation in baggage car.....	79	137
Garbage, disposal.....	82	142
Ice box, improvised.....	81	142
Fish.....	31, 33, 59	62, 65, 91
Foods:		
Beverages.....	39, 65	75, 100
Canned.....	37	73
Cereals, breakfast.....	38	74
Condiments.....	40	75
Corn meal and grits.....	41	76

Foods—Continued.	Paragraphs	Pages
Dairy products.....	35	70
Dressings, salad.....	47	79
Eggs.....	36	72
Extracts, flavoring.....	42	76
Fruits and vegetables.....	43	76
Inspection.....	14	6
Jams, jellies, preserves, and fruit butters.....	44	78
Kinds, qualities, and uses.....	16	15
Lard and lard substitute.....	45	78
Macaroni, noodles, and spaghetti.....	46	79
Purchase for mess.....	13	9
Seasoning.....	55	87
Sirup.....	48	79
Storage.....	15	10
Sugar.....	49	80
Tapioca.....	50	80
Vegetables.....	43, 60	76, 92
Frozen meats and fish.....	31	62
Fruit butters.....	44	78
Fruits and vegetables.....	43	76
Garbage, disposal.....	82	142
Gravy.....	62	97
Ice box, improvised.....	81	142
Kitchen management:		
Care of ranges and cooking utensils.....	74	109
Cooking:		
Assembling ingredients and utensils.....	72	108
Plan of work.....	71	107
Personal cleanliness of cooks.....	70	106
Service of meals.....	75	111
Stoves, ranges, and appliances, directions for use.....	73	108
Lard and lard substitute.....	45	78
Meats:		
Beef.....	17, 19	15, 21
Carving and serving.....	57	90
Cooking.....	52, 56	81, 88
Cutting of meats.....	18	16
Beef.....	20	22
Lamb.....	23	42
Pork.....	25	50
Smoked.....	27	55
Veal.....	29	57
Fish.....	31, 33, 59	62, 65, 91
Frozen.....	31	62
Lamb.....	22	40
Pork.....	24	47
Poultry.....	34	66

THE ARMY COOK

Meats—Continued.	Paragraphs	Pages
Sausage	32	64
Smoked	26	55
Specialties	30	60
Veal	28	57
 Nutrition:		
Energy foods	6	4
Functions of food (chart)	12	7
Minerals	8	5
Protein	7	4
Summary	11	6
Vitamins	9	5
Water	10	6
 Ranges:		
Care	74	109
Directions for use	73	108
 Rations:		
Definition	66	103
To whom issued	67	103
Army	68	103
Use	69	106
 Salads	 63	 97
 Terms used in cooking	 52	 81
 Wholesale market cuts of beef for small messes	 21	 40

[A. G. 062.11 (2-21-42).]

BY ORDER OF THE SECRETARY OF WAR:

G. C. MARSHALL,
Chief of Staff.

OFFICIAL:

J. A. ULIO,
Major General,
The Adjutant General.

DISTRIBUTION:

R and L (5); IC 8, 10 (10).

(For explanation of symbols see FM 21-6.)



NON-CIRCULATING BOOK

